



FOCUS LCDs

LCDs MADE SIMPLE®

Ph. 480-503-4295 | NOPP@FocusLCDs.com

TFT | OLED | CHARACTER | GRAPHIC | UWVD | SEGMENT | CUSTOM

TFT Display Module

Part Number

E55RB-I-MW346-C

Overview:

- 5.5-inch TFT (79.04x137.67)
- 1080x1920
- 4 Lane MIPI Interface
- Operating Temp 20C to 70C
- All Viewing Angle
- Transmissive, Normally Black
- Capacitive Touch Panel
- 346 nits
- TFT IC: XM91080
- CTP Controller: GT911
- RoHS Compliant

Description

This is a color active matrix TFT (Thin Film Transistor) LCD (Liquid Crystal Display) that uses amorphous silicon TFT as a switching device. This model is composed of a transmissive type TFT LCD Panel, driver circuit and a backlight unit. The resolution of the 5.5" TFT-LCD that contains 1080(RGB)x1920 pixels and can display up to 16.7M colors.

TFT Features

Low Input Voltage: 3.3V

Display Colors: 16.7M

Interface: 4-Lane MIPI

General Information	Specification	Unit	Note
	Main Panel		
Display Area(AA)	68.04(H)x120.96(V)(5.5 Inch)	mm	-
Driver Element	TFT active matrix	-	-
Display Colors	16.7M	colors	-
Number of Pixels	1080(RGB)x1920	dots	-
TFT Pixel Arrangement	RGB vertical stripe	-	-
Pixel Pitch	0.021(H)*0.063(V)	mm	-
Viewing Angle	ALL	o'clock	-
TFT Controller IC	XM91080	-	-
CTP Driver IC	GT911		
Display Mode	Transmissive/Normally Black	-	-
CTP and LCM Bonding Technology	Optical Bonding	-	-
Operating Temperature	-20~+70	°C	-
Storage Temperature	-30~+80	°C	-

*CTP Features

General Information	Specification	Unit	Note
	Main Panel		
Resolution	1080(H)*1920(V)	-	
Structure	G+G	-	
Controller IC	GT911	-	
Interface	I2C	-	
Slave Adress	0x5D(7bit) or 0x14(7bit)	-	Note1
Touch mode	Five points and Gestures	-	-
Logic level	3.3	V	

Mechanical Information

Item		Min	Typ.	Max	Unit	Note
Module Size	Horizontal (H)		79.04		mm	-
	Vertical (V)		137.67		mm	-
	Depth (D)		2.84		mm	-
	Weight		--		g	

1. Outline Dimensions

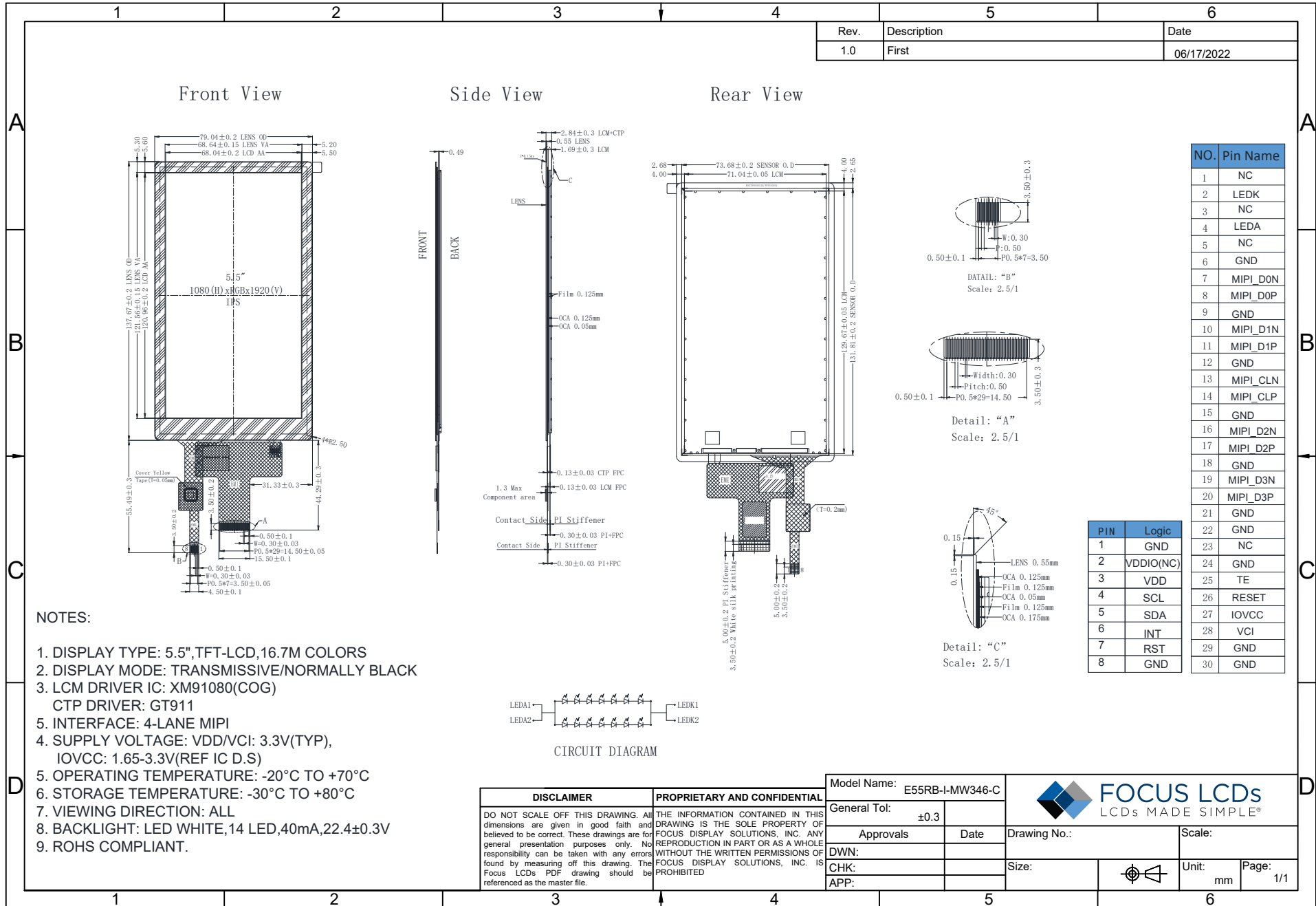

DISCLAIMER		PROPRIETARY AND CONFIDENTIAL		Model Name: E55RB-I-MW346-C	
DO NOT SCALE OFF THIS DRAWING. All dimensions are given in good faith and believed to be correct. These drawings are for general presentation purposes only. No responsibility can be taken with any errors found by measuring off this drawing. The Focus LCDs PDF drawing should be referenced as the master file.		THE INFORMATION CONTAINED IN THIS DRAWING IS THE SOLE PROPERTY OF FOCUS DISPLAY SOLUTIONS, INC. ANY REPRODUCTION IN PART OR AS A WHOLE WITHOUT THE WRITTEN PERMISSIONS OF FOCUS DISPLAY SOLUTIONS, INC. IS PROHIBITED		General Tol: ±0.3	
		Approvals		Date	
		DWN:		Drawing No.:	
		CHK:		Scale:	
		APP:		Size:	
				Unit: mm	
				Page: 1/1	

2. Block Diagram

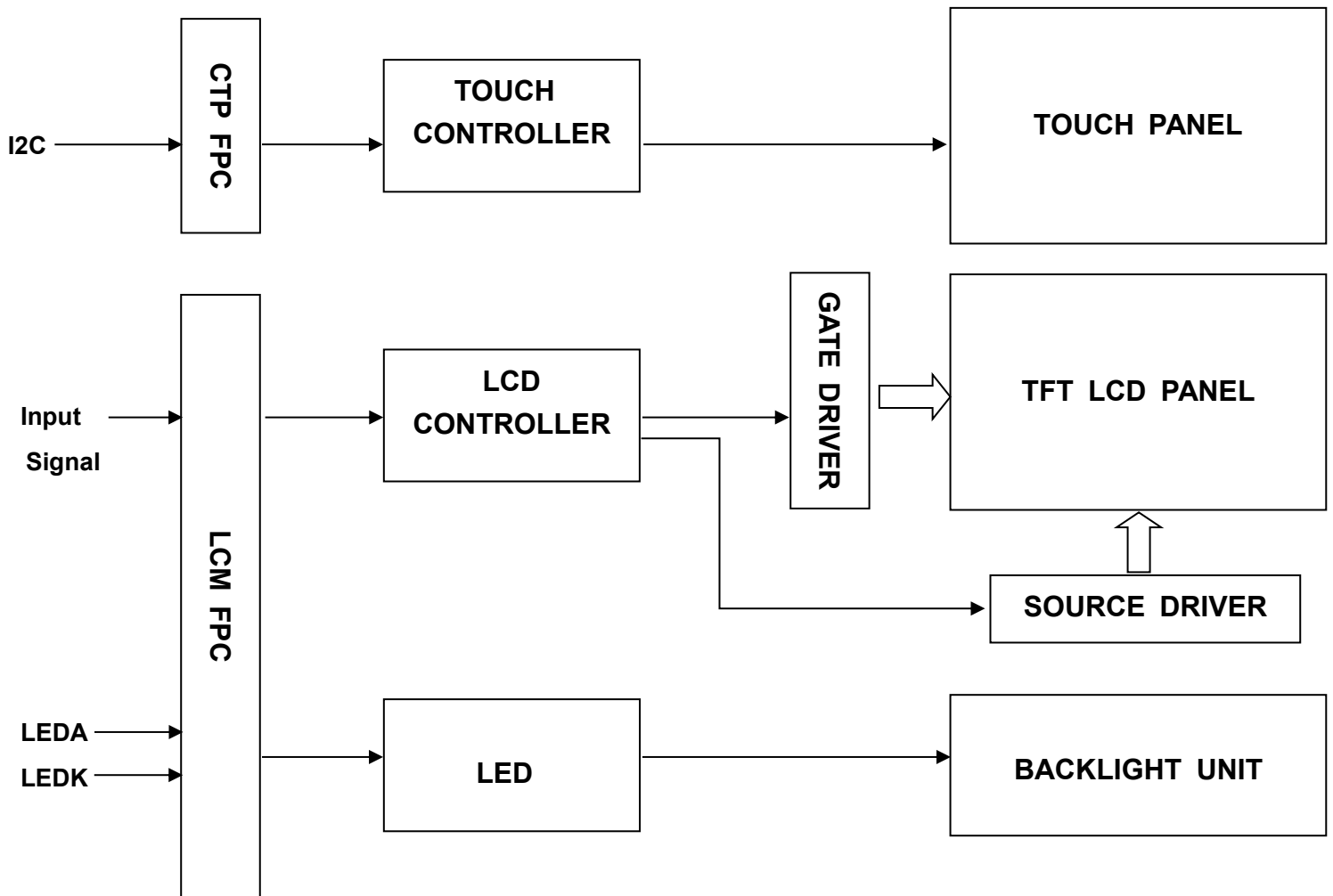

3. Input TFT Terminal Pin Assignment

Recommended Connector:F H12S-30S-0.5SH(55)

NO.	Symbol	Description	I/O
1	NC	NO CONNECTION	--
2	LEDK	Cathode pin of backlight.	P
3	NC	NO CONNECTION	--
4	LEDA	Anode pin of backlight.	P
5	NC	NO CONNECTION	--
6	GND	Ground	P
7	MIPI_D0N	MIPI DSI differential data pair (Data lane 0)	I/O
8	MIPI_D0P		
9	GND	Ground	P
10	MIPI_D1N	MIPI DSI differential data pair (Data lane 1)	I
11	MIPI_D1P		
12	GND	Ground	P
13	MIPI_CLN	MIPI DSI differential data pair .	I
14	MIPI_CLP		
15	GND	Ground.	P
16	MIPI_D2N	MIPI DSI differential data pair (Data lane 2)	I
17	MIPI_D2P		
18	GND	Ground	P
19	MIPI_D3N	MIPI DSI differential data pair (Data lane 3)	I
20	MIPI_D3P		
21	GND	Ground.	P
22	GND	Ground.	P
23	NC	NO CONNECTION	--
24	GND	Ground.	P
25	TE	Tearing effect output pin. Leave the pin open when not in use.	O
26	RESET	The external reset input. Initializes the chip with a low input. Be sure to execute a power-on reset after supplying power. Fix to IOVCC level when not in use.	I
27	IOVCC	Power supply for I/O pad.	I
28	VCI	Power supply for analog circuits.	I
29	GND	Ground.	P
30	GND	Ground.	P

3.1 CTP Pin Assignment

NO.	SYMBOL	DESCRIPTION	I/O/P
1	GND	Ground.	P
2	NC	--	--
3	VDD	Supply voltage.	P
4	SCL	I2C clock input.	I
5	SDA	I2C data input and output	I/O
6	INT	External interrupt to the host.	I
7	RST	External Reset, Low is active.	I
8	GND	Ground.	P

4. LCD Optical Characteristics

4.1 Optical Specifications

Item		Symbol	Condition	Min.	Typ.	Max.	Unit.	Note
Contrast Ratio		CR	$\Theta=0$	1000	1400	--		(1)(2)
Response time	Rising	T_{R+T_F}	Normal viewing angle	--	30	35	msec	(1)(3)
	Falling							
Color gamut		S(%)			66		%	(1)
Color Filter Chromaticity	White	W_X		0.2564	0.2964	0.3364		(1)(4)
		W_Y		0.3000	0.3400	0.3800		
	Red	R_X		0.6091	0.6291	0.6491		
		R_Y		0.3258	0.3458	0.3658		
	Green	G_X		0.3838	0.3038	0.3238		
		G_Y		0.5662	0.5862	0.6062		
	Blue	B_X		0.1299	0.1499	0.1699		
		B_Y		0.0353	0.0553	0.0753		
Viewing angle	Hor.	Θ_L	CR>10	70	80	--	Degree	(1)(4)
		Θ_R		70	80	--		
	Ver.	Θ_U		70	80	--		
		Θ_D		70	80	--		
Option View Direction		ALL						(5)

Optical Specification Reference Notes:

(1) Definition of Viewing Angle: The viewing angle is the angle at which the contrast ratio is greater than 10. The viewing angles are determined for the horizontal or 3,9 o'clock direction and the vertical or 6,12 o'clock direction with respect to the optical axis which is normal to the LCD surface.

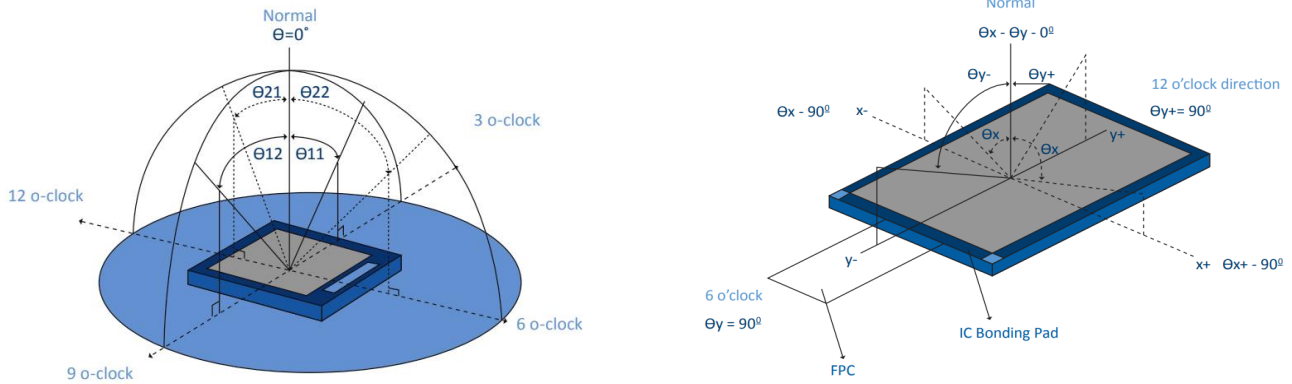

(2) Definition of Contrast Ratio (Cr): measured at the center point of panel. The contrast ratio (Cr) measured on a module, is the ratio between the luminance (Lw) in a full white area (R=G=B=1) and the luminance (Ld) in a dark area (R=G=B=0).

$$Cr = \frac{Lw}{Ld}$$

(3) Definition of transmittance (T%): The transmittance of the panel including the polarizers is measured with electrical driving. The equation for transmittance Tr is:

$$Tr = \frac{I_t}{I_o} \times 100\%$$

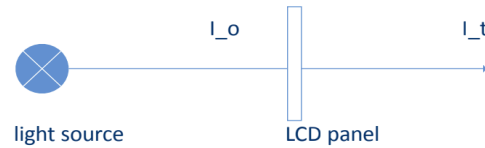

I_o = the brightness of the light source.

I_t = the brightness after panel transmission

(4) Definition of Response Time (T_r , T_f): The rise time ' T_r ' is defined as the time for luminance to change from 90% to 10% as a result of a change of the electrical condition. The fall time ' T_f ' is defined as the time for luminance to change from 10% to 90% as a result of a change of the electrical condition.

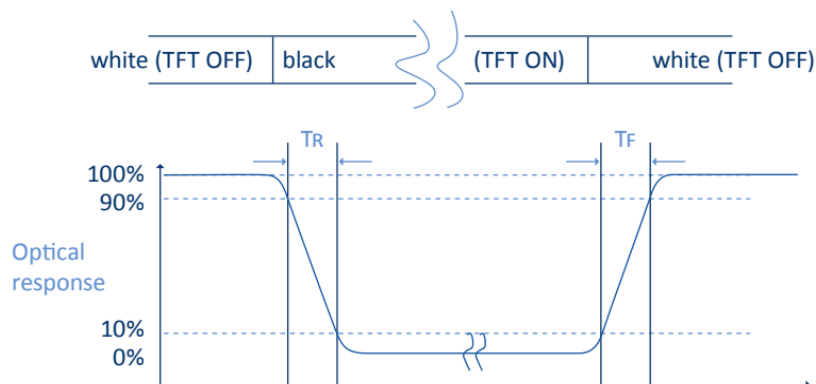

(5) Definition of Color Gamut:

Measuring machine CFT-01. NTSC's Primaries: $R(x,y,Y), G(x,y,Y), B(x,y,Y)$. FPM520 of Westar Display Technologies, INC., which utilized SR-3 for Chromaticity and BM-5A for other optical characteristics. The color chromaticity shall be calculated from the spectral data measured with all pixels first in red, green, blue and white. Measurements shall be made at the center of the panel.

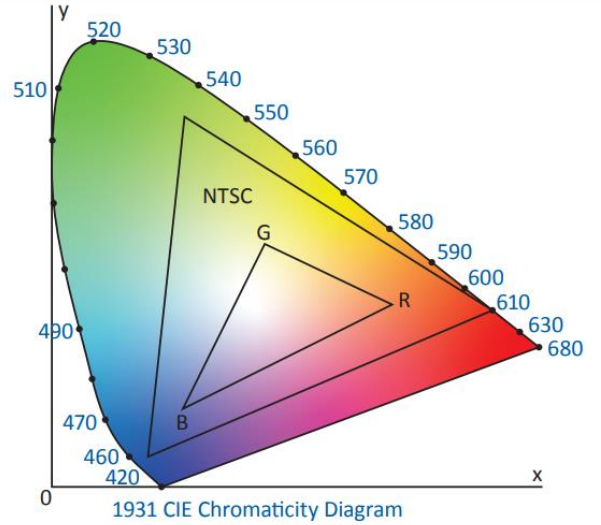
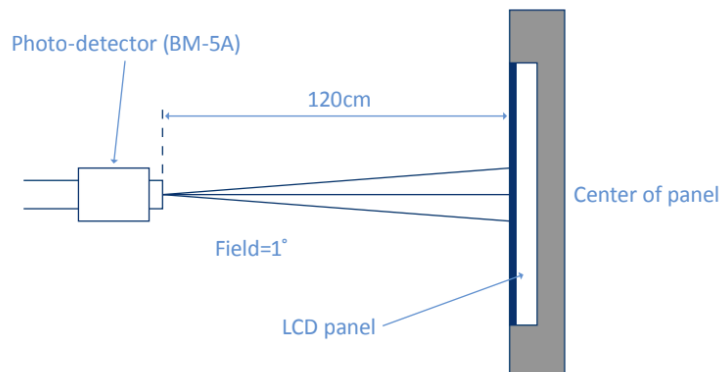
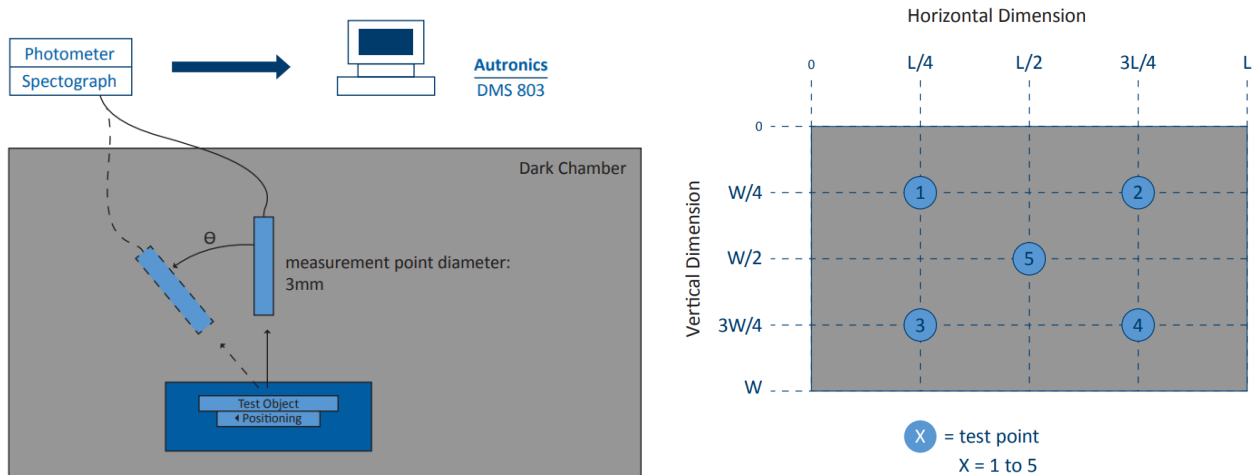

Fig. 1931 CIE chromacity diagram

$$\text{Color gamut: } S = \frac{\text{Area of RGB triangle}}{\text{Area of NTSC triangle}} \times 100\%$$

(6) Definition of Optical Measurement Setup:

The LCD module should be stabilized at a given temperature for 20 minutes to avoid abrupt temperature change during measuring. In order to stabilize the luminance, the measurement should be executed after lighting backlight for 20 minutes.



5. TFT Electrical Characteristics

5.1 Absolute Maximum Rating (Ta=25 °C, VSS=0V)

Characteristics	Symbol	Min	Max	Unit
Digital Supply Voltage	VCI	-0.3	4.6	V
Supply Voltage Logic	IOVCC	-0.3	4.6	V
Operating Temperature	TOP	-20	+70	°C
Storage Temperature	TST	-30	+80	°C

NOTE: If the absolute maximum rating of the above parameters is exceeded, even momentarily, the quality of the product may be degraded. Absolute maximum ratings specify the values which the product may be physically damaged if exceeded. Be sure to use the product within the range of the absolute maximum ratings.

5.2 DC Electrical Characteristics

Characteristics	Symbol	Min	Typ.	Max	Unit	Note
Power Supply Voltage	VCI	2.5	3.3	3.6	V	
Supply Voltage (Logic)	IOVCC	1.65	1.8	3.6	V	
Normal Mode Current	IDD	--	38	--	mA	
Level Input Voltage	VIH	0.7IOVCC	--	IOVCC	V	
	VIL	GND	--	0.3IOVCC	V	
Level Output Voltage	VOH	0.8IOVCC	--	IOVCC	V	
	VOL	GND	--	0.2IOVCC	V	

5.3 LED Backlight Characteristics

Item	Symbol	Min	Typ.	Max	Unit	Note
Forward Current	IF	30	40	--	mA	
Forward Voltage	VF	--	22.4	--	V	
LCM Luminance	LV	400	346	--	cd/m ²	Note 3
LED lifetime	Hr	50000	--	--	hour	Note1 & 2
Uniformity	AVg	80	--	--	%	Note 3

The back-light system is edge-lighting type with 8 white LEDs.

Note 1: LED lifetime (Hr) can be defined as the time in which it continues to operate under the condition: Ta=25±3 °C, typical IL value indicated in the above table until the brightness becomes less than 50%.

Note 2: The “LED lifetime” is defined as the module brightness decrease to 50% original brightness at Ta=25°C and IL=40mA. The LED lifetime could be decreased if operating IL is larger than 40mA. The constant current driving method is suggested.

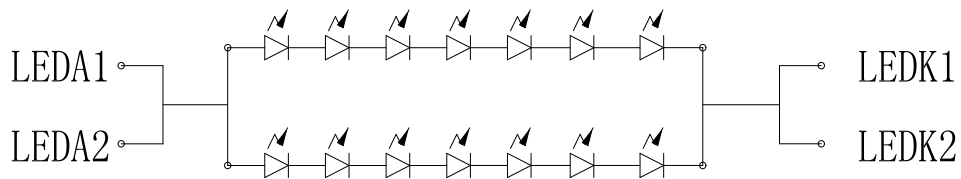

Note 3: Luminance Uniformity of these 9 points is defined as below:

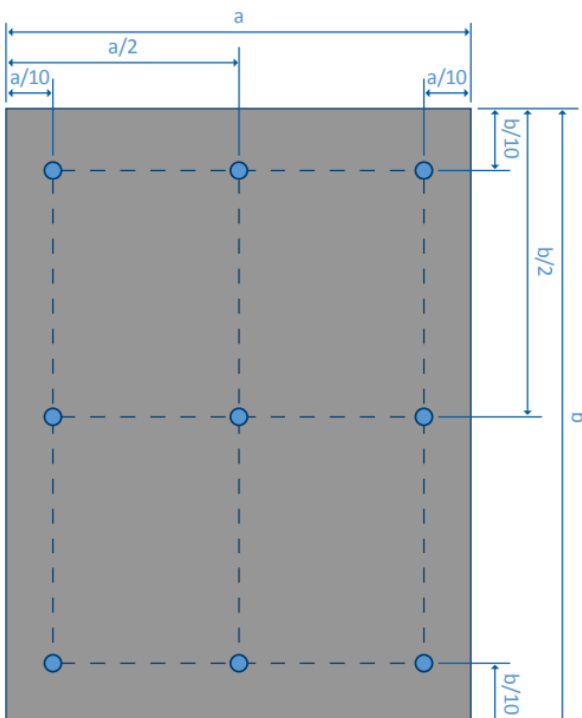

$$\text{Luminance} = \frac{\text{Total Luminance of 9 points}}{9}$$

$$\text{Uniformity} = \frac{\text{minimum luminance in 9 points(1-9)}}{\text{maximum luminance in 9 points(1-9)}}$$

6. Timing Characteristics

For more information about the timing characteristics of this module, please see the full specifications for controller GT911

7. Quality Inspection Standards

For TFT quality inspection standards, please see the following link:

<https://focuslcds.com/tft-quality-inspection-standards/>

8. Cautions and Handling Precautions

8.1 Handling and Operating the Module

1. When the module is assembled, it should be attached to the system firmly. Do not warp or twist the module during assembly work.
2. Protect the module from physical shock or any force. In addition to damage, this may cause improper operation or damage to the module and back-light unit.
3. Note that polarizer is very fragile and could be easily damaged. Do not press or scratch the surface.
4. Do not allow drops of water or chemicals to remain on the display surface. If you have the droplets for a long time, staining and discoloration may occur.
5. If the surface of the polarizer is dirty, clean it using some absorbent cotton or soft cloth.
6. The desirable cleaners are water, IPA (Isopropyl Alcohol) or Hexane. Do not use ketene type materials (ex. Acetone), Ethyl alcohol, Toluene, Ethyl acid or Methyl chloride. It might permanent damage to the polarizer due to chemical reaction.
7. If the liquid crystal material leaks from the panel, it should be kept away from the eyes or mouth. In case of contact with hands, legs, or clothes, it must be washed away thoroughly with soap.
8. Protect the module from static; it may cause damage to the CMOS ICs.
9. Use fingerstalls with soft gloves in order to keep display clean during the incoming inspection and assembly process.
10. Do not disassemble the module.
11. Protection film for polarizer on the module shall be slowly peeled off just before use so that the electrostatic charge can be minimized.
12. Pins of I/F connector shall not be touched directly with bare hands.
13. Do not connect, disconnect the module in the "Power ON" condition.
14. Power supply should always be turned on/off by the item Power On Sequence & Power Off Sequence.

8.2 Storage and Transportation.

1. Do not leave the panel in high temperature, and high humidity for a long time. It is highly recommended to store the module with temperature from 0 to 35 °C and relative humidity of less than 70%
2. Do not store the TFT-LCD module in direct sunlight.
3. The module shall be stored in a dark place. When storing the modules for a long time, be sure to adopt effective measures for protecting the modules from strong ultraviolet radiation, sunlight, or fluorescent light.
4. It is recommended that the modules should be stored under a condition where no condensation is allowed. Formation of dewdrops may cause an abnormal operation or a failure of the module. In particular, the greatest possible care should be taken to prevent any module from being operated where condensation has occurred inside.
5. This panel has its circuitry FPC on the bottom side and should be handled carefully in order not to be stressed.