



FocusLCDs.com  
LCDs MADE SIMPLE®

Ph. 480-503-4295 | [NOPP@FocusLCD.com](mailto:NOPP@FocusLCD.com)

TFT | CHARACTER | UWVD | FSC | SEGMENT | CUSTOM | REPLACEMENT

## TFT Display Module

Part Number

E35RG63224LW2M350-N

### Overview:

- 3.5-inch TFT: 320x240 (76.84x63.84)
- 16/18/24-bit RGB Interface
- Wide Temp
- Internal Power Supply Circuit
- White LED back-light
- Transmissive/ Normally White
- No Touch Panel
- 350 NITS
- Controller: HX8238D
- RoHS Compliant

## Description

This is a color active matrix TFT (Thin Film Transistor) LCD (Liquid Crystal Display) that uses amorphous silicon TFT as a switching device. This model is composed of a Transmissive type TFT-LCD Panel, driver circuit, back-light unit. The resolution of a 3.5" TFT-LCD contains 480 x 640 pixels and can display up to 16.7M colors.

## Features

Low Input Voltage: 3.3V (TYP)

Display Colors of TFT LCD: 16.7M colors

Interface: MIPI

@ 1080p 60FPS

General Information Items	Specification	Unit	Note
	Main Panel		
Display area (AA)	480 (H) * 640 (V) (3.5 inch)	mm	-
Driver element	TFT active matrix	-	-
Display colors	16.7M	colors	-
Number of pixels	480(RGB)*640	dots	-
TFT Pixel arrangement	RGB vertical stripe	-	-
Pixel pitch	0.12 (H) x 0.15 (V)	mm	-
Viewing angle		o'clock	-
TFT Controller IC	HX8357	-	-
Display mode	Transmissive/Normally ‡	-	-
Operating temperature	-20~+70	°C	-
Storage temperature	-30~+80	°C	-

## Mechanical Information

Item		Min	Typ.	Max	Unit	Note
Module size	Horizontal(H)				mm	-
	Vertical(V)				mm	-
	Depth(D)		3.0		mm	-
Weight			TBD		g	-

## 1. Block Diagram

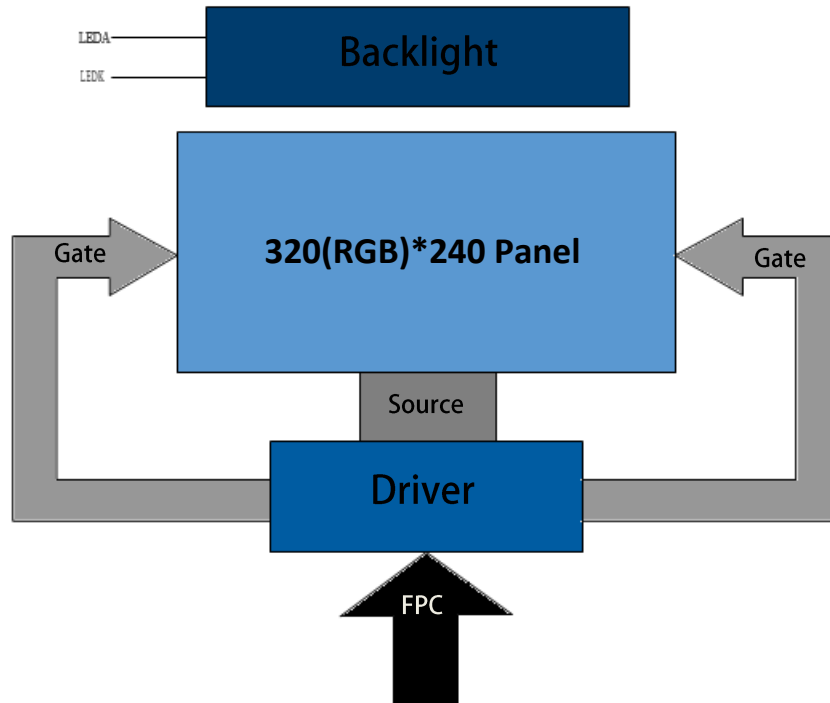

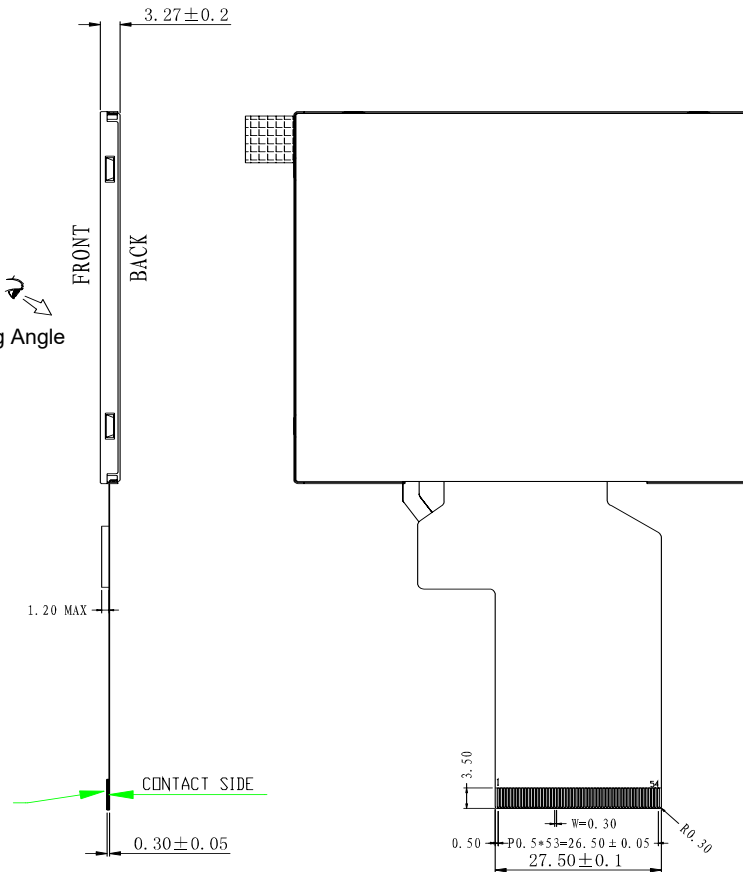
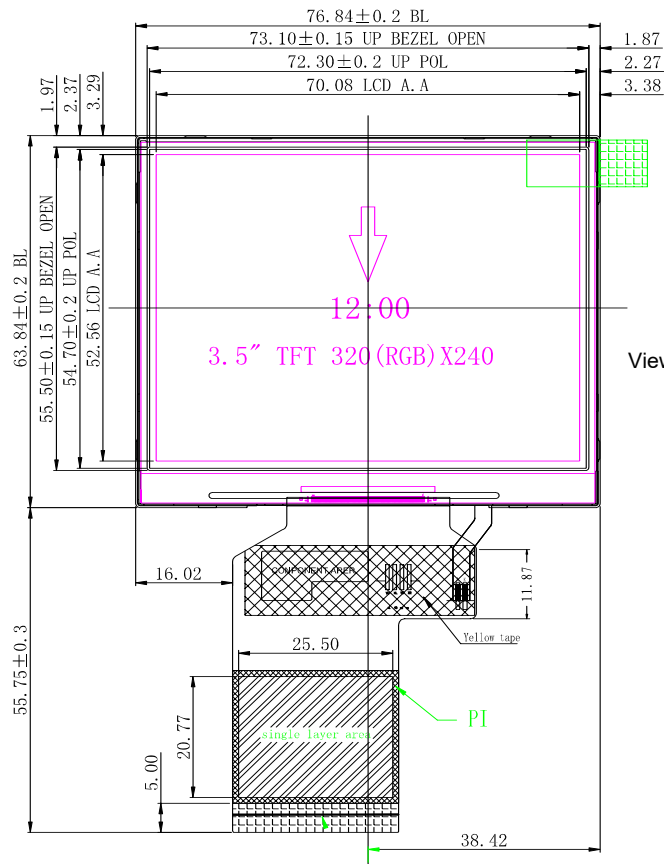

NO.	Pin Name
1	VBL-
2	VBL-
3	VBL+
4	VBL+
5	YU
6	XR
7	NC
8	/RESET
9	CSB
10	SCK
11	SDI
12	B0
13	B1
14	B2
15	B3
16	B4
17	B5
18	B6
19	B7
20	G0
21	G1
22	G2
23	G3
24	G4
25	G5
26	G6
27	G7
28	R0
29	R1
30	R2
31	R3
32	R4
33	R5
34	R6
35	R7
36	HSYNC
37	VSYNC
38	DCLK
39	NC
40	NC
41	VDD
42	VDD
43	YD
44	XL
45	NC
46	NC
47	NC
48	SEL2
49	SEL1
50	SEL0
51	NC
52	DE
53	GND
54	GND

NOTES:

1. DISPLAY TYPE: 3.5", TFT-LCD, 65K/262K/16.7M COLORS
2. DISPLAY MODE: T/M NORMALLY WHITE
3. VIEWING DIRECTION: 12:00
4. DRIVER IC: HX8238D (COG)
5. INTERFACE: 16BIT/18BIT/24BIT-RGB
6. VCI: 3.3V(TYP)
7. OPERATING TEMP: -20°C TO 70°C  
STORAGE TEMP: -30°C TO 80°C
8. BACK LIGHT: LED WHITE, 6 LED, 20mA, 18.6±0.3V
9. RoHS COMPLIANT.

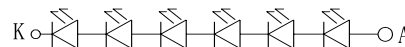

B/L Circuit

ReV.	Revision content description	Date
V0	FIRST	2014/05/23

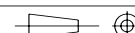

**FocusLCDs.com**  
LCDs MADE SIMPLE®

TOLERANCE		DRAWING NAME	E35RG63224LW2M350-N
TOLERANCE UNLESS	X.X±0.3	Drawn	Unit
OTHERWISE SPECIFIED	X.XX±0.2	Checked	mm
Scale 1:1		Approve	Page 1/1

### 3. Input Terminal Pin Assignment

Recommended Connector: F32R-1A7H1-11054

NO.	Symbol	Description	I/O
1	BLK	Cathode pin of backlight	P
2	BLK	Cathode pin of backlight	P
3	BLA	Anode pin of backlight	P
4	BLA	Anode pin of backlight	P
5	YU(NC)	Touch panel top film terminal	A/D
6	XR(NC)	Touch panel right glass terminal	A/D
7	NC		
8	RESET	System reset pin. Internal pull high. Connect to VDDIO when not used.	I
9	CSB	Chip select of serial interface. Internal pull high. Leave open when not used.	I
10	SCK	Clock pin of serial interface. Internal pull high. Leave open when not used.	I
11	SDI	Data input pin of serial interface. Internal pull high. Leave open when not used.	I
12-19	B0-B7	Blue data input.	I
20-27	G0-G7	Green data input.	I
28-35	R0-R7	Red data input.	I
36	HSYNC	Horizontal sync input. Negative polarity.	I
37	VSYNC	Vertical sync input. Negative polarity.	I
38	DCLK	Clock signal. Latching data at the rising edge.	I
39	NC		
40	NC		
41	VDD	Supply voltage (3.3V)	P
42	VDD	Supply voltage (3.3V)	P
43	YD(NC)	Touch panel bottom film terminal	A/D
44	XL(NC)	Touch panel left glass terminal	A/D
45-47	NC		
48	SEL2	Input pin to select input interface mode.	I
49	SEL1	Input pin to select input interface mode.	I
50	SEL0	Input pin to select input interface mode.	I
51	NC		
52	DE	Data input enable. Active high to enable the data input bus under "DE mode". Leave open when not used.	I
53	GND	Ground	P
54	GND	Ground	P

## 4. LCD Optical Characteristics

### 4.1 Optical specification

Item	Symbol	Condition	Min	Typ.	Max	Unit	Note
Contrast Ratio	CR	$\Theta=0$ Normal viewing angle	200	300	--		(2)
Transmittance	T%		--	7.4	--	%	(3)
Response time	Rising		Tr	--	15	30	ms
	Falling	Tf		35	50	ms	
Color Filter Chromaticity	White	$W_x$	0.282	0.312	0.342		(5)(6)
		$W_y$	0.319	0.349	0.379		
	Red	$R_x$	0.609	0.639	0.669		
		$R_y$	0.314	0.344	0.374		
	Green	$G_x$	0.264	0.294	0.324		
		$G_y$	0.557	0.587	0.617		
	Blue	$B_x$	0.102	0.132	0.162		
		$B_y$	0.106	0.136	0.166		
Viewing angle	Hor.	$\Theta_L$	--	45	--	deg	(1)(6)
		$\Theta_R$	--	45	--		
	Ver.	$\Theta_U$	--	15	--		
		$\Theta_D$	--	35	--		
Option View Direction	12:00						

### 4.2 Measuring conditions

Measuring surrounding: dark room

Ambient temperature:  $25 \pm 2$  °C

15min. warm-up time.

**Optical Specification Reference Notes:**

(1) Definition of Viewing Angle: The viewing angle is the angle at which the contrast ratio is greater than 10. The viewing angles are determined for the horizontal or 3,9 o'clock direction and the vertical or 6,12 o'clock direction with respect to the optical axis which is normal to the LCD surface.

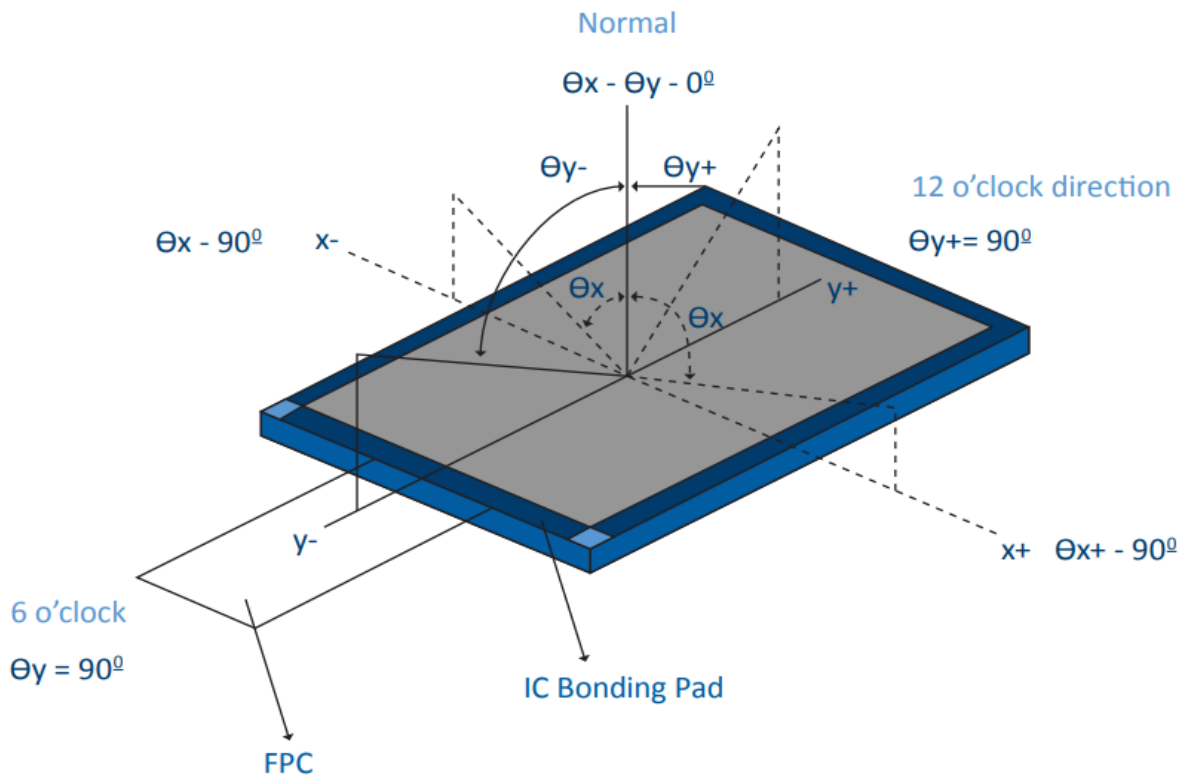
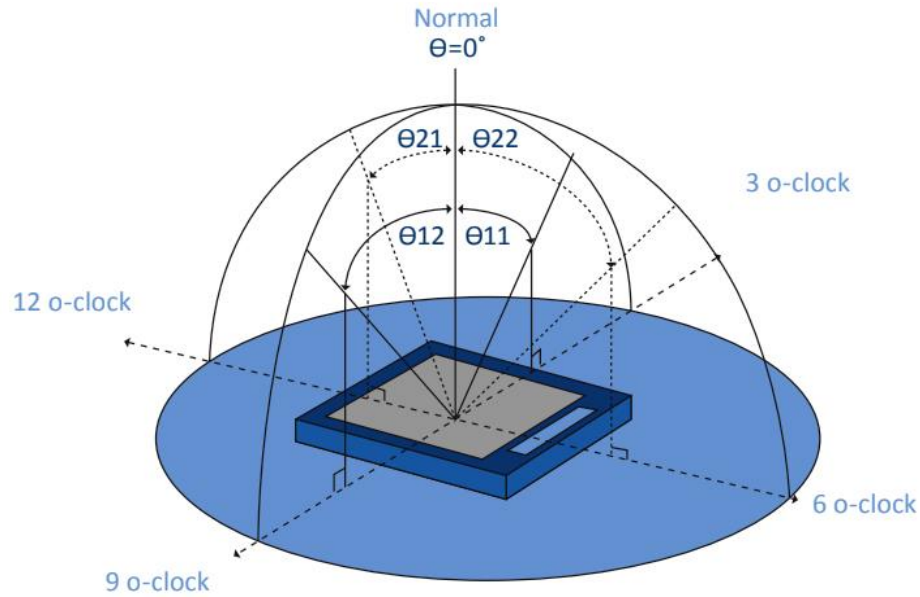

(2) Definition of Contrast Ratio (Cr): measured at the center point of panel. The contrast ratio (Cr) measured on a module, is the ratio between the luminance (Lw) in a full white area (R=G=B=1) and the luminance (Ld) in a dark area (R=G=B=0).

$$Cr = \frac{Lw}{Ld}$$

(3) Definition of transmittance (T%): The transmittance of the panel including the polarizers is measured with electrical driving.

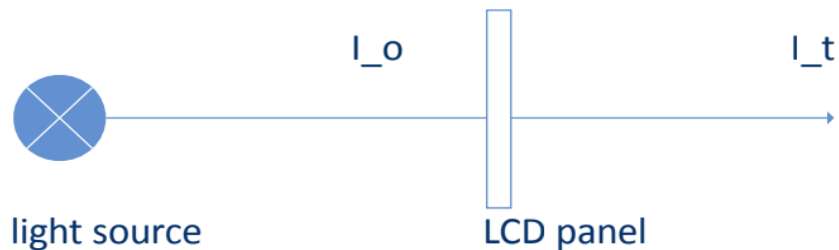

The transmittance is defined as:

$$Tr = \frac{I_t}{I_o} \times 100\%$$

I<sub>o</sub> = the brightness of the light source.

I<sub>t</sub> = the brightness after panel transmission

(4) Definition of Response Time (Tr, Tf): The rise time 'Tr' is defined as the time for luminance to change from 90% to 10% as a result of a change of the electrical condition. The fall time 'Tf' is defined as the time for luminance to change from 10% to 90% as a result of a change of the electrical condition.

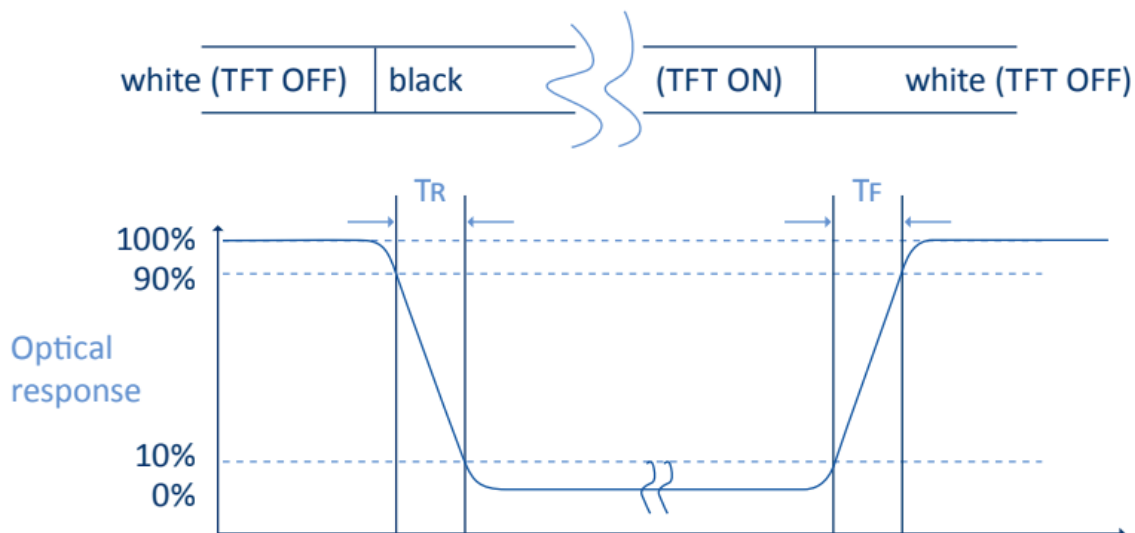



(5) Definition of Color Gamut: Measuring machine CFT-01. NTSC's Primaries: R(x,y,Y),G(x,y,Y), B(x,y,Y). FPM520 of Westar Display Technologies, INC., which utilized SR-3 for Chromaticity and BM-5A for other optical characteristics.

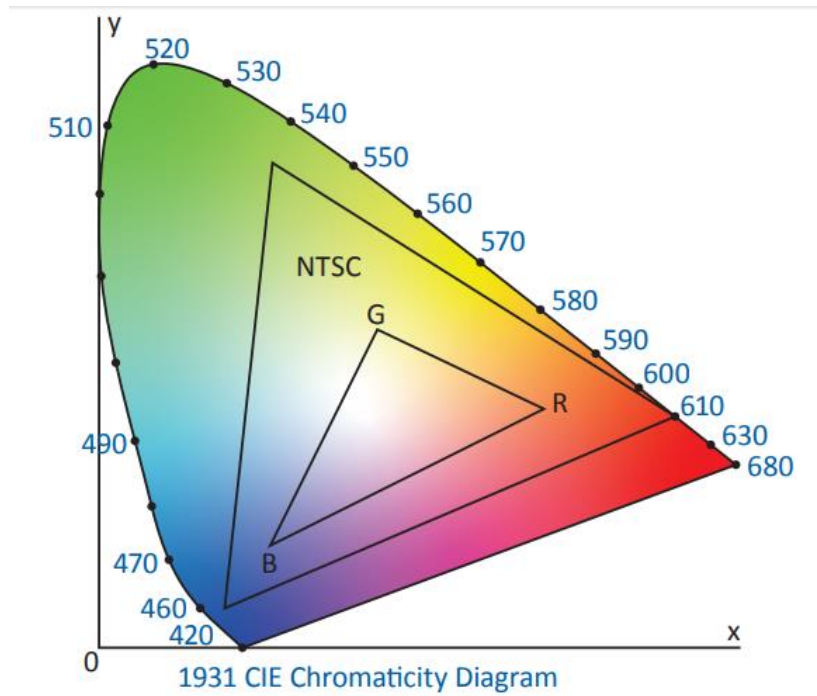
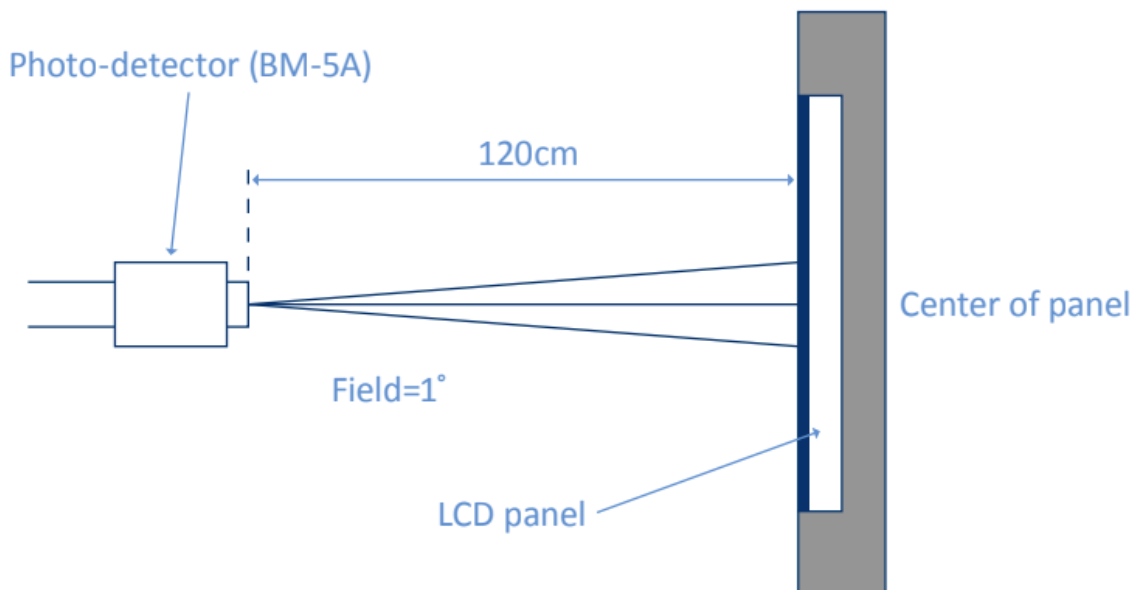

Fig. 1931 CIE chromacity diagram

$$\text{Color gamut: } S = \frac{\text{Area of RGB triangle}}{\text{Area of NTSC triangle}} \times 100\%$$

(6) Definition of Optical Measurement Setup:



(6) Optical Measurement Setup Continued:

The LCD module should be stabilized at a given temperature for 20 minutes to avoid abrupt temperature change during measuring. In order to stabilize the luminance, the measurement should be executed after lighting backlight for 20 minutes.

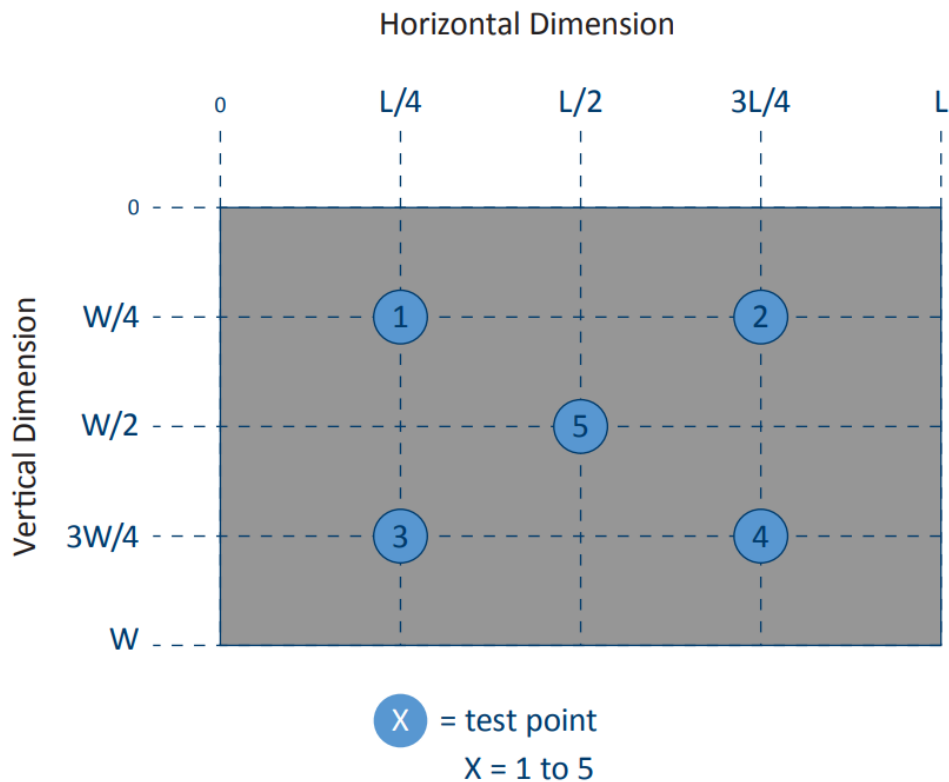
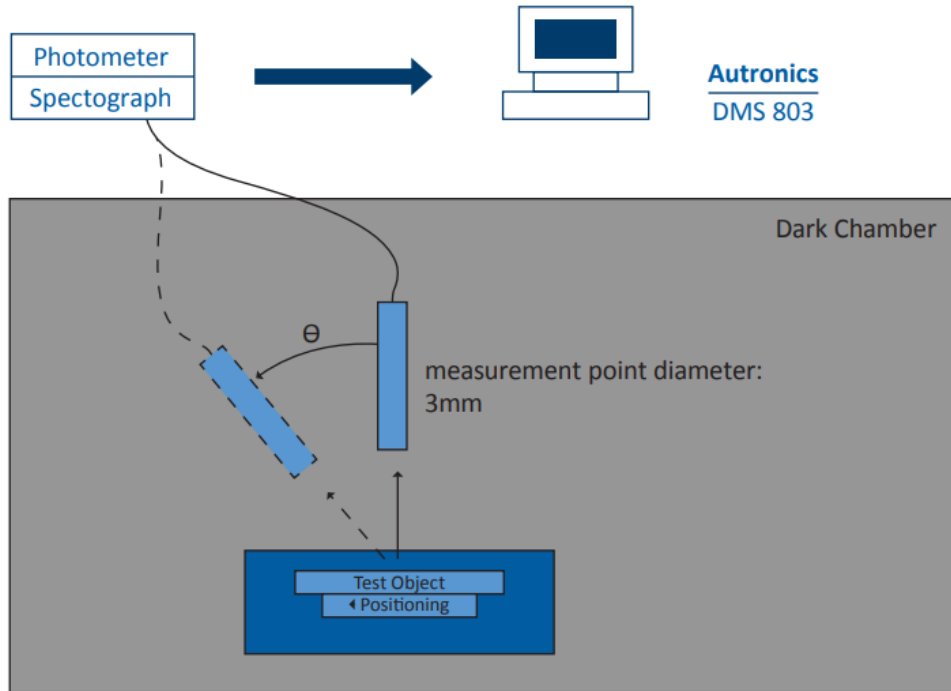

## 5. Electrical Characteristics

### 5.1 Absolute Maximum Rating (Ta=25 VSS=0V)

Characteristics	Symbol	Min	Max	Unit
Digital Supply Voltage	VDD	3.0	5.0	V
Interface Supply Voltage	VDDIO	-0.3	4.0	V
Operating temperature	TOP	-20	+70	°C
Storage temperature	TST	-30	+80	°C

NOTE: If the absolute maximum rating of even is one of the above parameters is exceeded even momentarily, the quality of the product may be degraded. Absolute maximum ratings, therefore, specify the values exceeding which the product may be physically damaged. Be sure to use the product within the range of the absolute maximum ratings.

### 5.2 DC Electrical Characteristics

Characteristics	Symbol	Min	Typ.	Max	Unit	Note
Digital Supply Voltage	VCI/VDD	3.0	3.3	3.6	V	
Interface Operation Voltage	VDDIO	1.6	3.3	3.6	V	
Normal Mode Current Consumption	IDD	--	10	--	mA	
Level input voltage	VIH	0.7 VDDIO		VDDIO	V	
	VIL	GND		0.3 VDDIO	V	
Level output voltage	VOH	VDDIO-0.4			V	
	VOL	GND		GND+0.4	V	

### 5.3 LED Backlight Characteristics

Item	Symbol	Min	Typ.	Max	Unit	Note
Forward Current	IF	15	20	--	mA	
Forward Voltage	VF	--	19.2	--	V	
LCM Luminance	LV	350	--	--	cd/m2	Note 3
LED lifetime	Hr	50000	--	--	hour	Note1 & 2
Uniformity	AVg	80	--	--	%	Note 3

The back-light system is edge-lighting type with 6 chips White LED

Note 1: LED lifetime (Hr) can be defined as the time in which it continues to operate under the condition:

Ta=25±3 °C, typical IL value indicated in the above table until the brightness becomes less than 50%.

Note 2: The “LED lifetime” is defined as the module brightness decrease to 50% original brightness at Ta=25°C and IL=20mA. The LED lifetime could be decreased if operating IL is larger than 20mA. The constant current driving method is suggested.

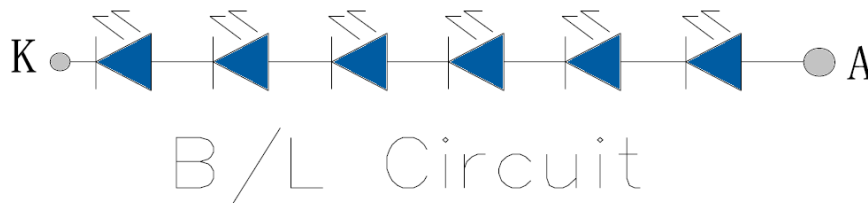

Note 3: Luminance Uniformity of these 9 points is defined as below:

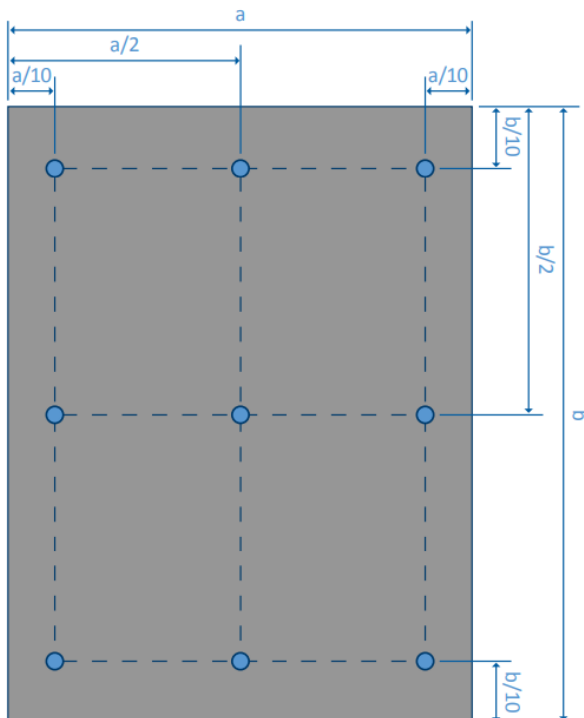

$$\text{Luminance} = \frac{\text{Total Luminance of 9 points}}{9}$$

$$\text{Uniformity} = \frac{\text{minimum luminance in 9 points(1-9)}}{\text{maximum luminance in 9 points(1-9)}}$$

## 6. AC Characteristic

### 6.1 Display Parallel RGB Interface Timing Characteristics

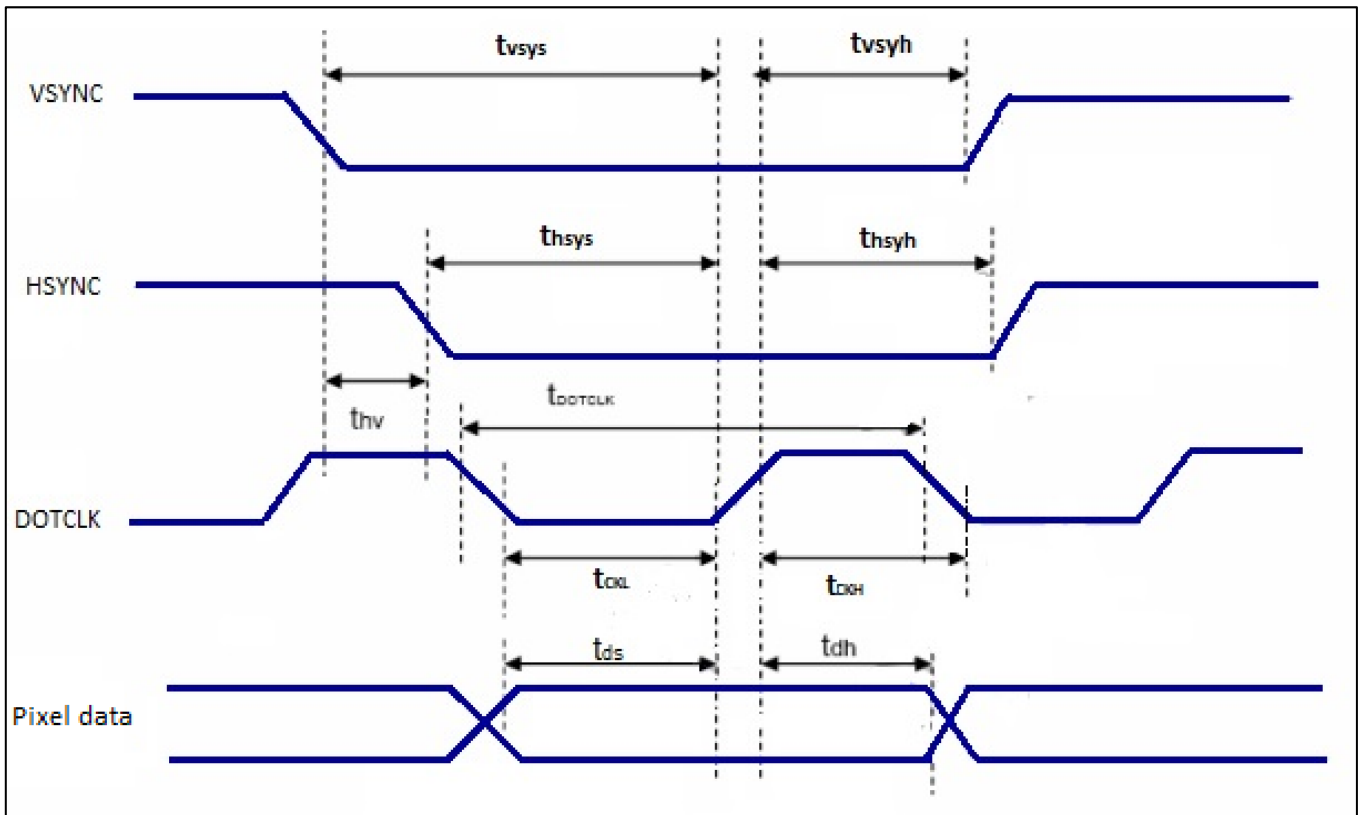

Figure 6.1: Parallel RGB Interface Timing Diagram

AC Electrical Characteristics (VDDIO=VDD=20 to 3.6V, GND=0V, TA=-20 to 85°C)

Characteristics	Symbol	Min		Typ.		Max		Unit
		24bit	8bit	24bit	8bit	24bit	8bit	
DOTCLK frequency	fDOTCLK	-	-	6.5	19.5	10	30	MHz
DOTCLK period	tDOTCLK	100	33.3	154	51.3	-	-	ns
Vertical sync setup time	tvsys	20	10	-	-	-	-	ns
Vertical sync hold time	tvsyh	20	10	-	-	-	-	ns
Horizontal sync setup time	thsys	20	10	-	-	-	-	ns
Horizontal sync hold time	thsyh	20	10	-	-	-	-	ns
Phase difference of sync signal falling edge	thv	1	1	-	-	240	240	tDOTCLK
DOTCLK low period	tCKL	50	15	-	-	-	-	ns
DOTCLK high period	tCKH	50	15	-	-	-	-	ns
Data setup time	tds	12	10	-	-	-	-	ns
Data hold time	tdh	12	10	-	-	-	-	ns
Reset pulse width	tRES	10	10	-	-	-	-	ns

Table 6.1: Parallel RGB Interface Timing Characteristics

Note: External clock source must be provided to DOTCLK pin of HX8238-D. The driver will not operate if absent of the clocking signal.

## 6.2 Clock and Data Input Waveforms

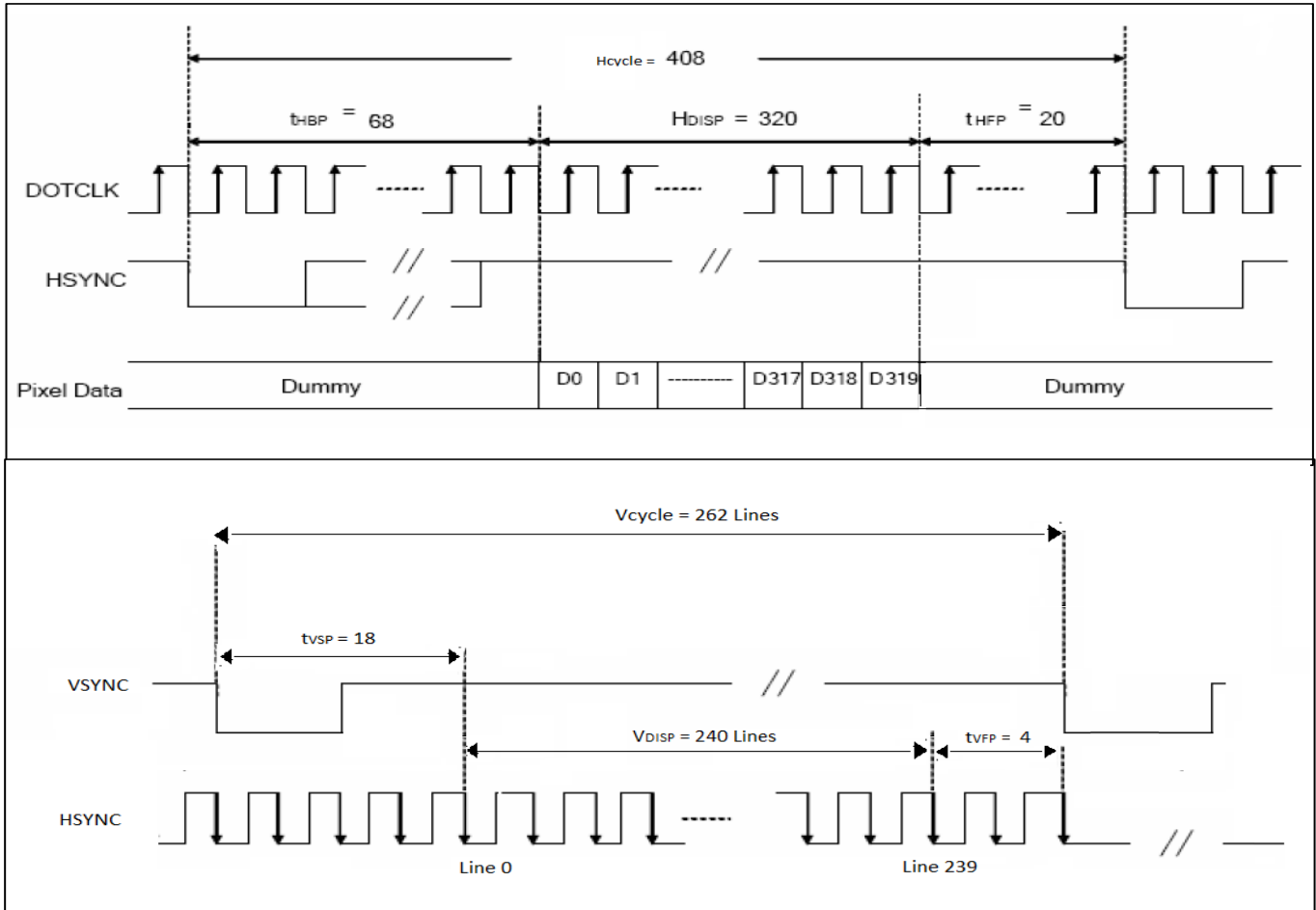

Figure 6.2: Vertical and Horizontal Data Transaction Timing Diagram

Characteristics	Symbol	Min		Typ.		Max		Unit
		24bit	8bit	24bit	8bit	24bit	8bit	
DOTCLK Frequency	fDOTCLK	-	-	6.5	19.5	10	30	MHz
DOTCLK Period	tDOTCLK	100	33.3	154	51.3	-	-	ns
Horizontal Frequency (Line)	fH	-	-	14.9		22.35		kHz
Vertical Frequency (Refresh)	fV	-	-	60		90		Hz
Horizontal Back Porch	tHBP	-	-	68	204	-	-	tDOTCLK
Horizontal Front Porch	tHFP	-	-	20	60	-	-	tDOTCLK
Horizontal Data Start Point	tHBP	-	-	68	204	-	-	tDOTCLK
Horizontal Blanking Period	tHBP+tHFP	-	-	88	264	-	-	tDOTCLK
Horizontal Display Area	HDISP	-	-	320	960	-	-	tDOTCLK
Horizontal Cycle	Hcycle	-	-	408	1224	450	1350	tDOTCLK
Vertical Back Porch	tVBP	-	-	18		-	-	Lines
Vertical Front Porch	tVFP	-	-	4		-	-	Lines
Vertical Data Start Point	tVBP	-	-	18		-	-	Lines
Vertical Blanking Period	tVBP+tVFP	-	-	22		-	-	Lines
Vertical Display Area	NTSC	-	-	240		-	-	Lines
	PAL			280(PALM=0)				
	PAL			288(PALM=1)				
Vertical Cycle	NTSC	-	-	262		350		Lines
	PAL			313				

Table 6.2: Vertical and Horizontal Timing Characteristics

### 6.3 Reset Timing

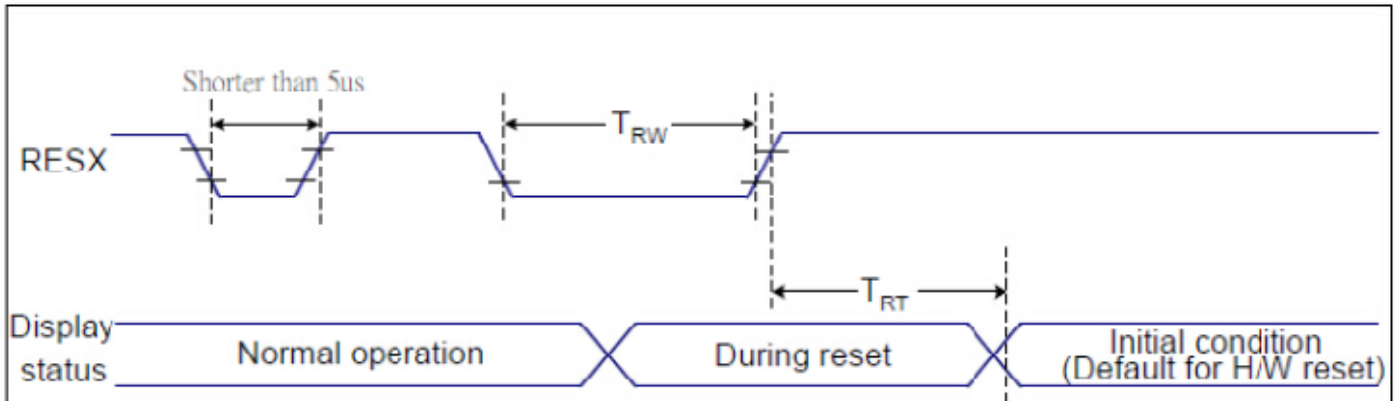

Figure 6.3: Reset Timing Diagram

Related Pins	Symbol	Parameter	Min	Max	Unit
RESX	TRW	Reset pulse duration	10	-	us
	TRT	Reset cancel	-	5 (Note 1,5)	ms
				120 (Note 1, 6, 7)	ms

Notes:

- The reset cancel includes also required time for loading ID bytes, VCOM setting and other settings from NVM (or similar device) to registers. This loading is done every time when there is HW reset cancel time (tRT) within 5ms after a rising edge of RESX.
- Spike due to an electrostatic discharge on RESX line does not because irregular system reset according to the table below:

RESX Pulse	Action
Shorter than 5us	Reset Rejected
Longer than 9us	Reset
Between 5us and 9 us	Reset starts

- During the resetting period, the display will be blanked (the display is entering blanking sequence, which maximum time is 120ms, when reset starts in Sleep Out mode. The display remains the blank state in Sleep in mode) and then return to Default condition for Hardware Reset.
- Spike Rejection also applies during a valid reset pulse as shown below:

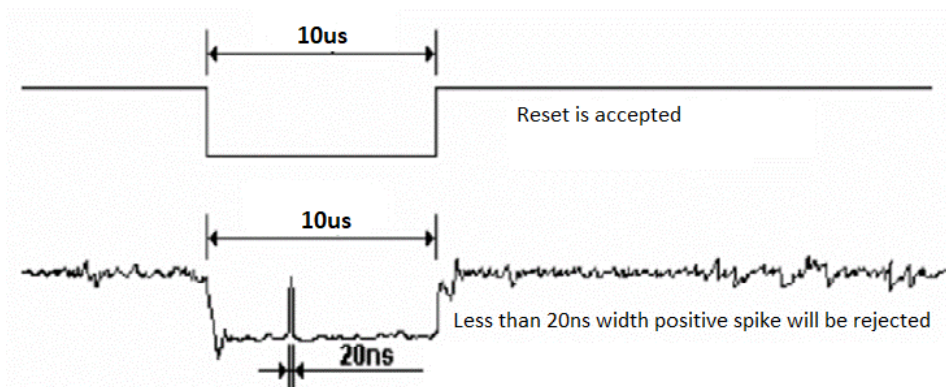

- When Reset applied during Sleep In Mode.
- When Reset applied during Sleep Out Mode.
- It is necessary to wait 5ms after releasing RESX before sending commands. Also Sleep Out command cannot be sent for 120ms.

## 7. Cautions and Handling Precautions

### 7.1 Handling and Operating the Module

1. When the module is assembled, it should be attached to the system firmly. Do not warp or twist the module during assembly work.
2. Protect the module from physical shock or any force. In addition to damage, this may cause improper operation or damage to the module and back-light unit.
3. Note that polarizer is very fragile and could be easily damaged. Do not press or scratch the surface.
4. Do not allow drops of water or chemicals to remain on the display surface. If you have the droplets for a long time, staining and discoloration may occur.
5. If the surface of the polarizer is dirty, clean it using some absorbent cotton or soft cloth.
6. The desirable cleaners are water, IPA (Isopropyl Alcohol) or Hexane. Do not use ketene type materials (ex. Acetone), Ethyl alcohol, Toluene, Ethyl acid or Methyl chloride. It might permanent damage to the polarizer due to chemical reaction.
7. If the liquid crystal material leaks from the panel, it should be kept away from the eyes or mouth. In case of contact with hands, legs, or clothes, it must be washed away thoroughly with soap.
8. Protect the module from static; it may cause damage to the CMOS ICs.
9. Use fingerstalls with soft gloves in order to keep display clean during the incoming inspection and assembly process.
10. Do not disassemble the module.
11. Protection film for polarizer on the module shall be slowly peeled off just before use so that the electrostatic charge can be minimized.
12. Pins of I/F connector shall not be touched directly with bare hands.
13. Do not connect, disconnect the module in the "Power ON" condition.
14. Power supply should always be turned on/off by the item Power On Sequence & Power Off Sequence

### 7.2 Storage and Transportation.

1. Do not leave the panel in high temperature, and high humidity for a long time. It is highly recommended to store the module with temperature from 0 to 35 °C and relative humidity of less than 70%
2. Do not store the TFT-LCD module in direct sunlight.
3. The module shall be stored in a dark place. When storing the modules for a long time, be sure to adopt effective measures for protecting the modules from strong ultraviolet radiation, sunlight, or fluorescent light.
4. It is recommended that the modules should be stored under a condition where no condensation is allowed. Formation of dewdrops may cause an abnormal operation or a failure of the module. In particular, the greatest possible care should be taken to prevent any module from being operated where condensation has occurred inside.
5. This panel has its circuitry FPC on the bottom side and should be handled carefully in order not to be stressed.