

## Data sheet

### OpDAT Industry SC-RJ/2SC SM adapter insert

Page 1/5

P/N

1402K00820MI

EAN 4250184115892

2023/04/05

Version: T

## Illustrations



Dimensional drawing

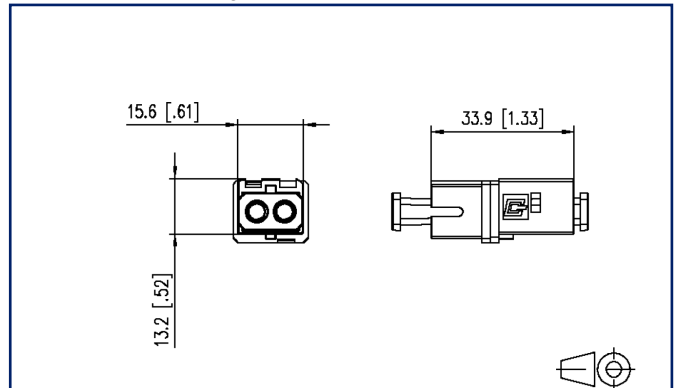

See enlarged drawings at the end of document

## Product specification

- SC-RJ/2SC adapter
- slotted ceramics sleeve for single mode applications
- slotted metal sleeve (Ph-Br) for multi mode applications
- conformity with relevant IEC framework specifications with regard to testing conditions and connector compatibility unilaterally to connector version SC to IEC 61754-4, IEC 60874-14 and SC-RJ to IEC 61745-24, EN 50377-6-1
- compliance with EN 50173-1 or ISO/IEC 24702 with regard to the limits for insertion loss
- flame-retardant and halogen-free plastic housing
- flame-retardant and halogen-free dust cover
- in flange or wall outlet of var. 1 and 4 - suitable for integration
- variant 14 only available in sets
- service life: min. 500 plug-in cycles
- operating temperature -40°C to +70°C
- variants: blue (SM), beige (MM)



### Technical Data

#### General Data

Mechanical measurement according to MICE	M1
Ingress measurement according to MICE	I1
Climatic measurement according to MICE	C1
Electromagnetic measurement according to MICE	E3
Design	coupler / adapter (FO)
Transmission technology	Fiber optic
Color	blue
Dimensions	
Dimension (L x W x H)	33.9 mm x 15.6 mm x 13.2 mm
Dimension (L x W x H)	1.335 in. x 0.614 in. x 0.52 in.
Mode type of the fiber	Singlemode
Labeling option	on housing

#### Connections/interfaces

Connector technology interface 1	SC-RJ/2SC
Connector technology interface 2	SC-RJ/2SC
Number of ports interface 1	1
Number of ports interface 2	1
Number of equipped ports interface 1	1
Number of ports interface 2 equipped	1
Number of ports with dust protection interface 1	1
Number of ports with dust protection interface 2	1

#### Electrical characteristics

Insertion loss	max. 0.5 dB
Return loss	max. 40 dB

#### Mechanical data

Cut-out	SC, LC-D, E2000
Mounting method	snap-in function
Insertion and withdrawal force	min. 30 N
Life - Number of mating cycles	min. 1000

### Technical Data

#### Materials and material properties

Material - Sleeve	ceramic, slotted
Halogen free	yes
RoHS	compliant

#### Environmental conditions

Temperature (min. - max.)	
Temperature - Storage °C	-40 °C - 70 °C
Temperature - Storage °F	-40 °F - 158 °F
Temperature - Operating °C	-40 °C - 70 °C
Temperature - Operating °F	-40 °F - 158 °F

#### Standards/Regulations

Generic cabling systems	
Industrial area	ISO/IEC 24702 AMD 1   DIN EN 50173-3 ANSI/TIA-1005

#### Classifications

ETIM 5.0	EC000752
ETIM 6.0	EC000752
ETIM 7.0	EC000752
ETIM 8.0	EC000752
ETIM 9.0	EC000752

#### Packing details

Type of packaging	10 pc(s) / box
Packaging unit - Weight (gram)	115 g
Packaging unit - Weight (pound)	0.25 lb
Packaging dimension	89 mm x 250 mm x 105 mm
Packaging dimension	3.504 in. x 9.843 in. x 4.134 in.

# P | Cabling

Data sheet

Page 4/5

## OpDAT Industry SC-RJ/2SC SM adapter insert

P/N

1402K00820MI

EAN 4250184115892

2023/04/05

Version: T

### Accessories from

P/N	Designation
1401010110ME	E-DAT Industry IP67 V1 1 port metal outlet
1401010220ME	E-DAT Industry IP67 V1 2 port metal outlet
1401010620ME	E-DAT Industry IP67 V1 2 port metal surface mount housing
1401013300ME	Industry IP67 V1 metal bulkhead
1401013300ME-F5	Industry IP67 V1 metal bulkhead
1401013302KE	Industry IP67 V1 bulkhead
1401040110ME	E-DAT Industry IP67 V4 1 port metal outlet
1401040220ME	E-DAT Industry IP67 V4 2 port metal outlet
1401040620ME	E-DAT Industry IP67 V4 2 port metal surface mount housing
1401043302KE	Industry IP67 V4 bulkhead
140UPB-E	E-DAT Industry universal test jack IP65, unequipped

# P | Cabling

Data sheet

Page 5/5

## OpDAT Industry SC-RJ/2SC SM adapter insert

P/N

1402K00820MI

EAN 4250184115892

2023/04/05

Version: T

### Illustrations

Dimensional drawing

