



Datasheet

Part No.:

DSGP.1575.15.4.A.02

Description:

GPS L1 / GALILEO E1 1575MHz
Ceramic SMD Patch Antenna

Features:

2.59 dBi Peak Gain for GPS/GALILEO Band
SMD Mount Ceramic Patch Antenna
Dimension: 15 x 15 x 4mm
Automotive IATF16949 Production and Quality
Approved
RoHS Compliant

 **RoHS**

1. Introduction	3
2. Specifications	4
3. Antenna Characteristics	5
4. 2D Radiation Patterns	8
5. 3D Radiation Patterns	10
6. Mechanical Drawing	11
7. Antenna Integration Guide	12
8. Evaluation Board Mechanical Drawing	17
9. PCB Footprint Recommendation	18
10 Packaging	20
Changelog	21

Taoglas makes no warranties based on the accuracy or completeness of the contents of this document and reserves the right to make changes to specifications and product descriptions at any time without notice. Taoglas reserves all rights to this document and the information contained herein.

Reproduction, use or disclosure to third parties without express permission is strictly prohibited.

Copyright © Taoglas Ltd.



1. Introduction



The DSGP.1575.15.4.A.02 is a ceramic GPS L1 / GALILEO E1 passive patch antenna. With a footprint of 15mm square and a height of just 4mm, this antenna is perfect for applications in compact telematics devices, vehicle tracking/fleet management systems, wearables, and navigation devices.

DSGP.1575 has been tuned on a 50*50mm ground plane, operating at 1575.42MHz with a 2.59dBi gain. The ceramic patch is mounted via SMT processes, suitable for high volume low cost assembly.

This antenna is manufactured and tested in a TS16949 first tier automotive approved facility. Taoglas can custom tune this antenna to specific device environments, subject to NRE and MOQ. For more details, please contact your regional Taoglas customer support team.

2. Specifications

ELECTRICAL	
Application Bands	GPS L1/GALILEO E1
Frequency	1575.42 ±1.023 MHz
Return Loss	<-10
Efficiency	67%
Peak Gain	2.6 dBi
Average Gain	-1.76 dB
Polarization	RHCP
Impedance	50 Ω
MECHANICAL	
Dimensions	15 x 15 x 4 mm
Material	Ceramic
Weight	3.3g
ENVIRONMENTAL	
Operation Temperature	-40°C to 85°C
Storage Temperature	-40°C to 105°C
Humidity	Non-condensing 65°C 95% RH
Moisture Sensitivity Level (MSL)	3 (168 Hours)

* Antenna properties were measured with the antenna mounted on 50*50mm Ground Plane

3. Antenna Characteristics

3.1 Return Loss S11

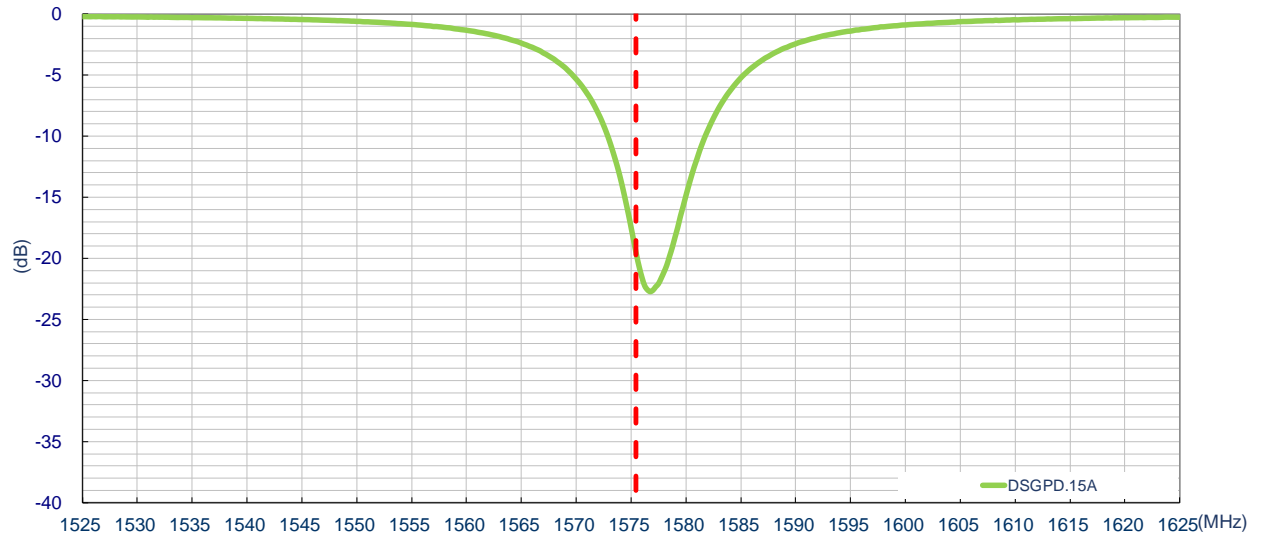

3.2 Efficiency

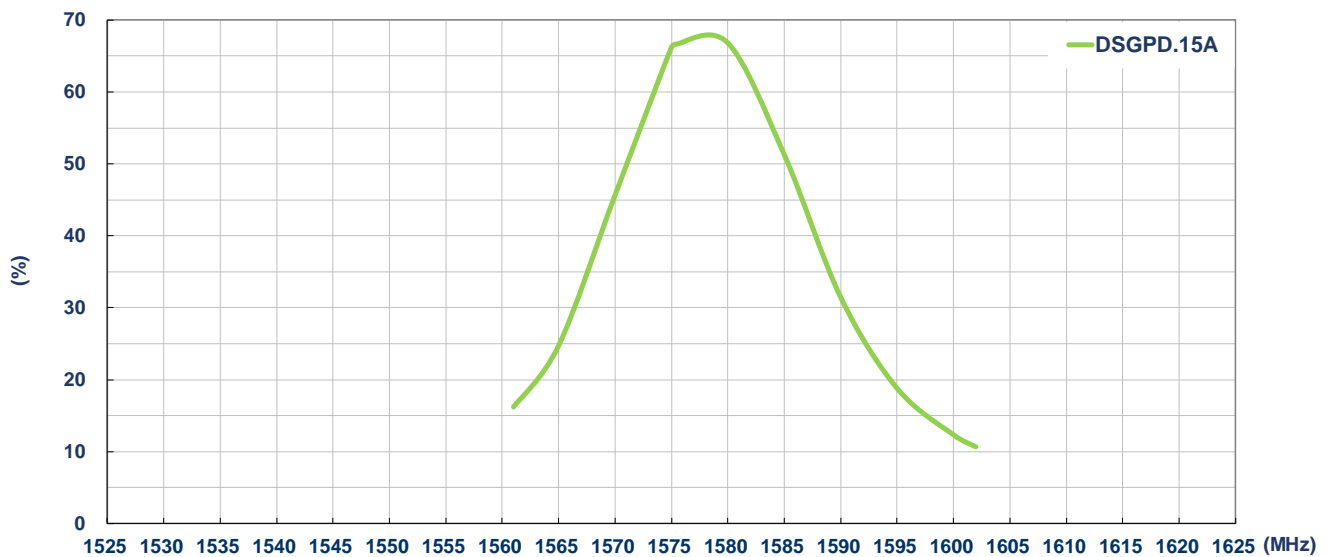

3.3 Peak Gain

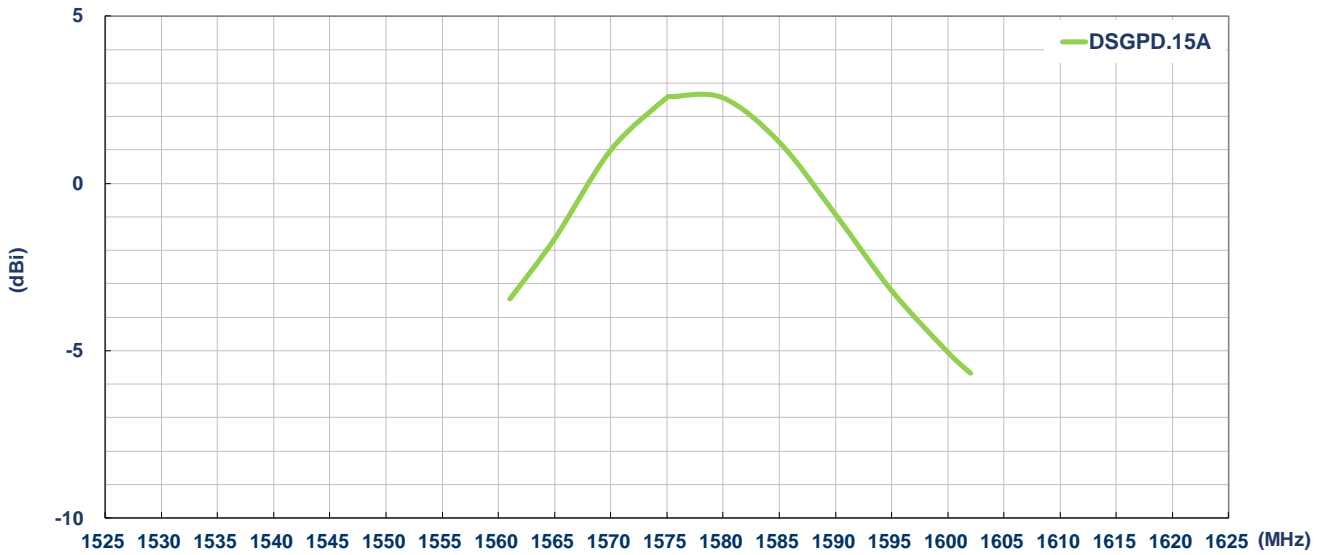

3.4 Average Gain

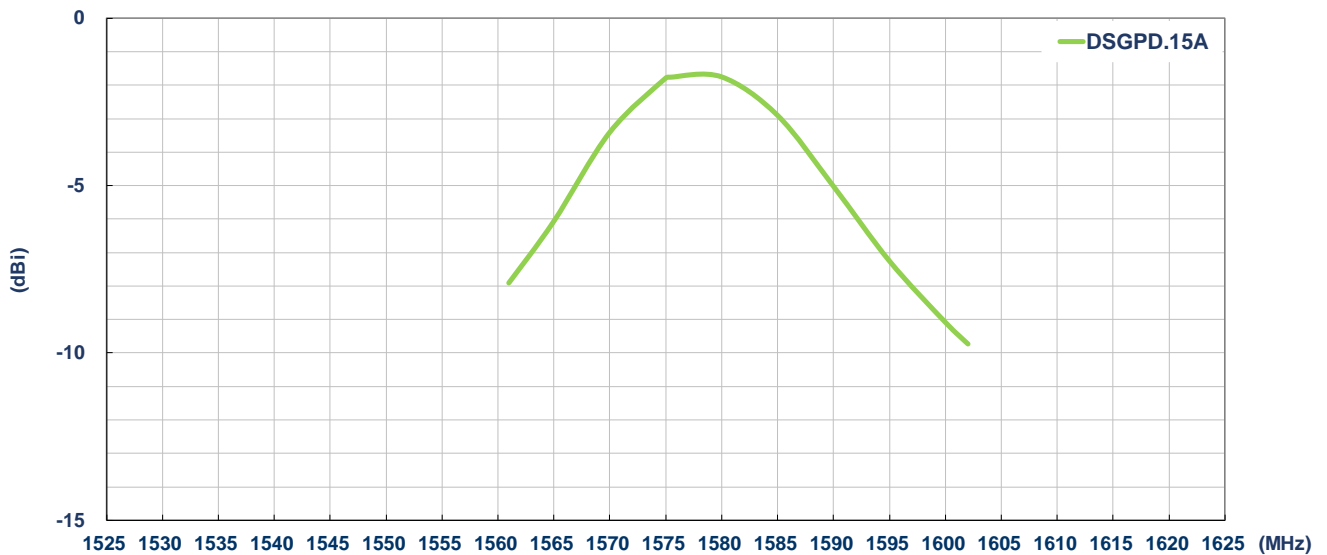

3.5 Axial Ratio @ Phi=0°

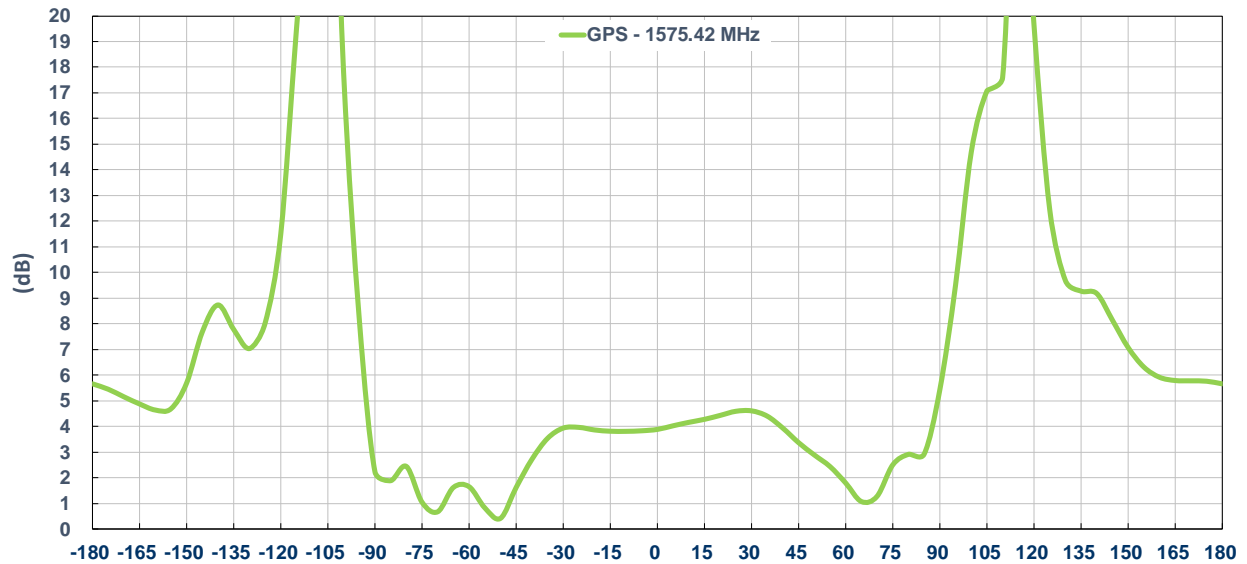

3.6 Axial Ratio @ Phi=90°

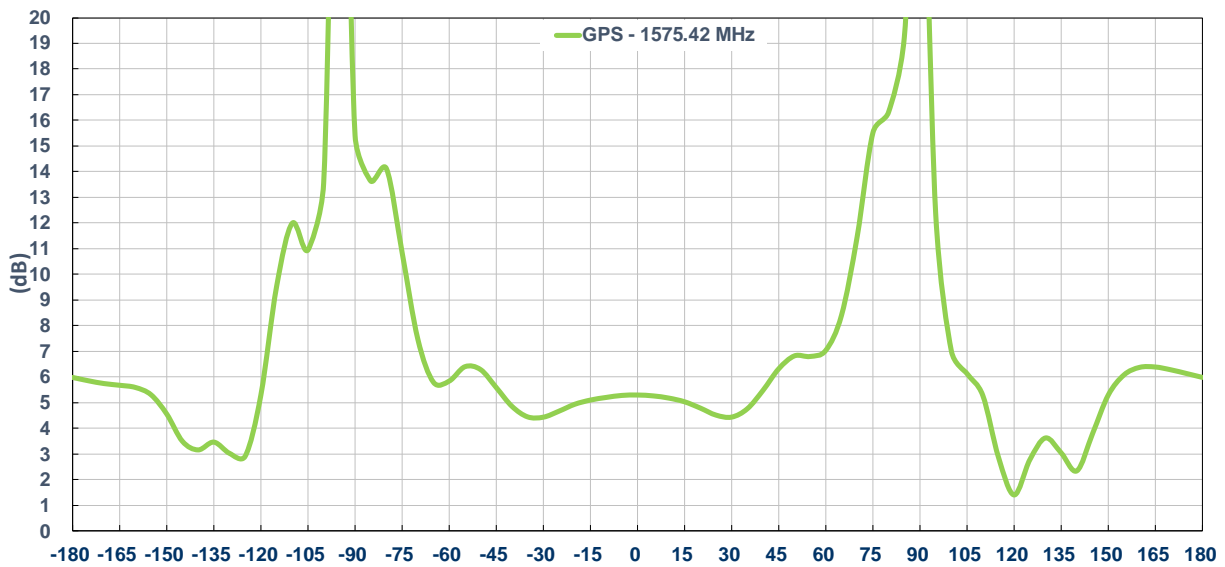

4. 2D Radiation Patterns

4.1 Test Setup

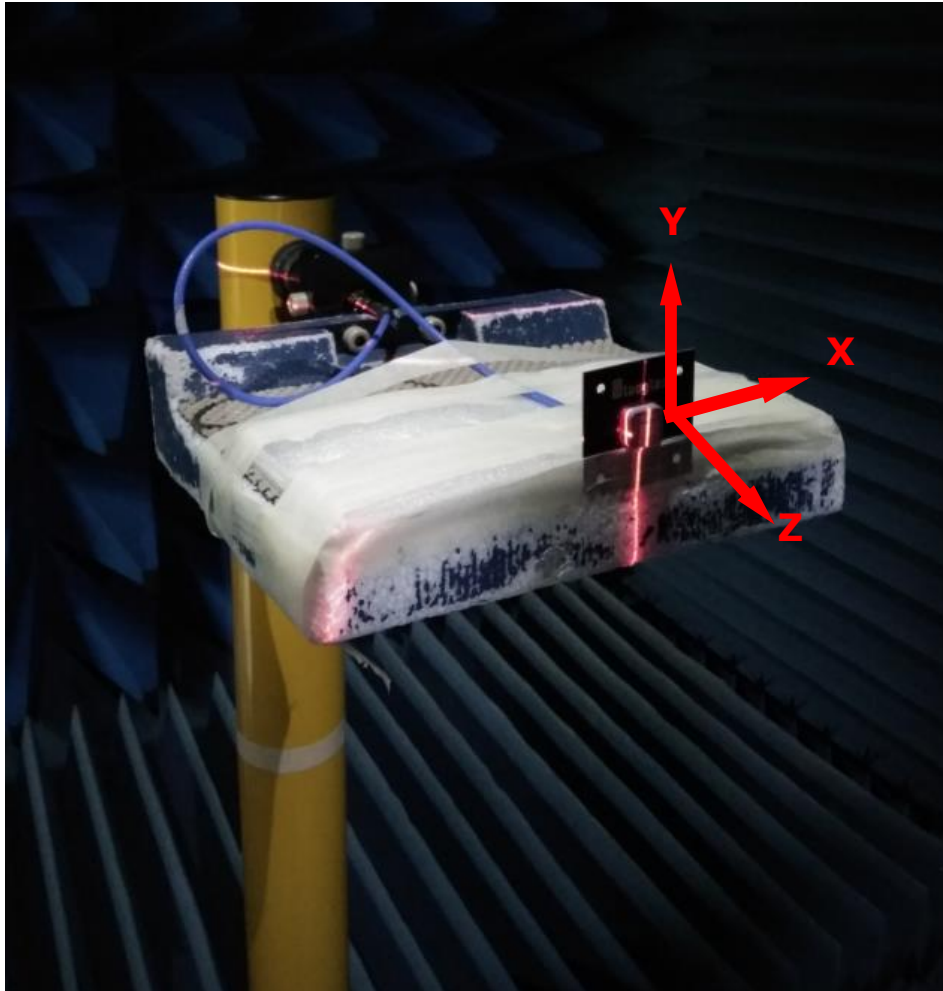

XY Plane

X

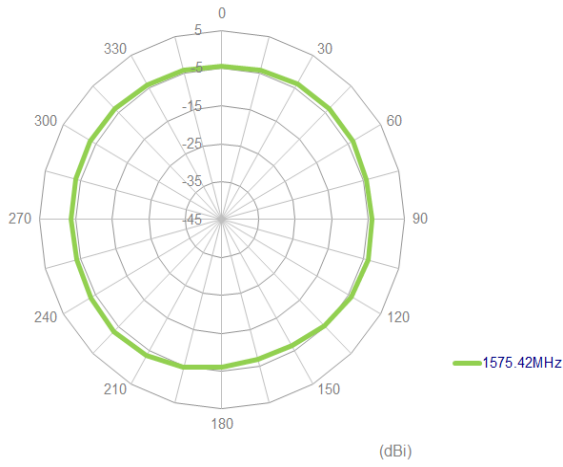

XZ Plane

Z

Y

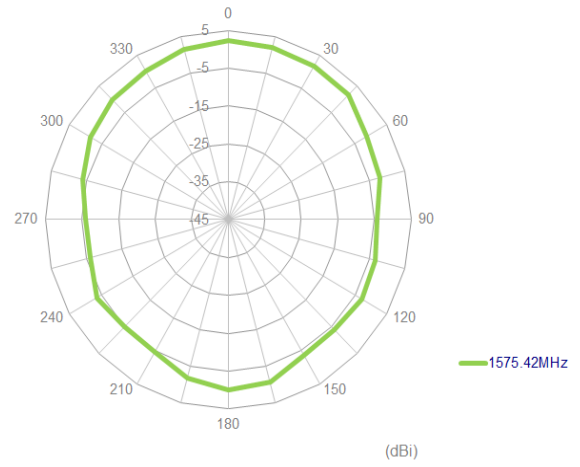

X

YZ Plane

Z

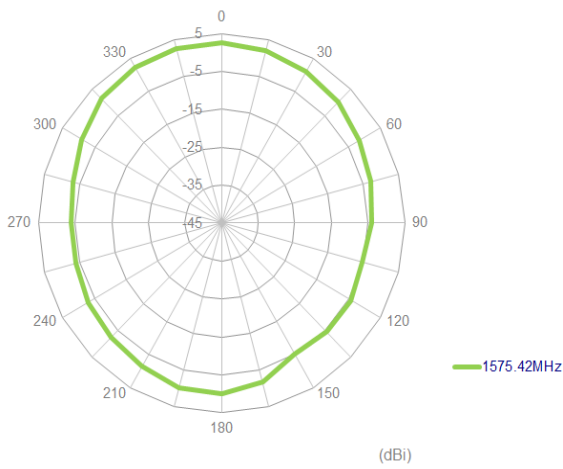

Y

5. 3D Radiation Patterns

5.1 1575.42MHz

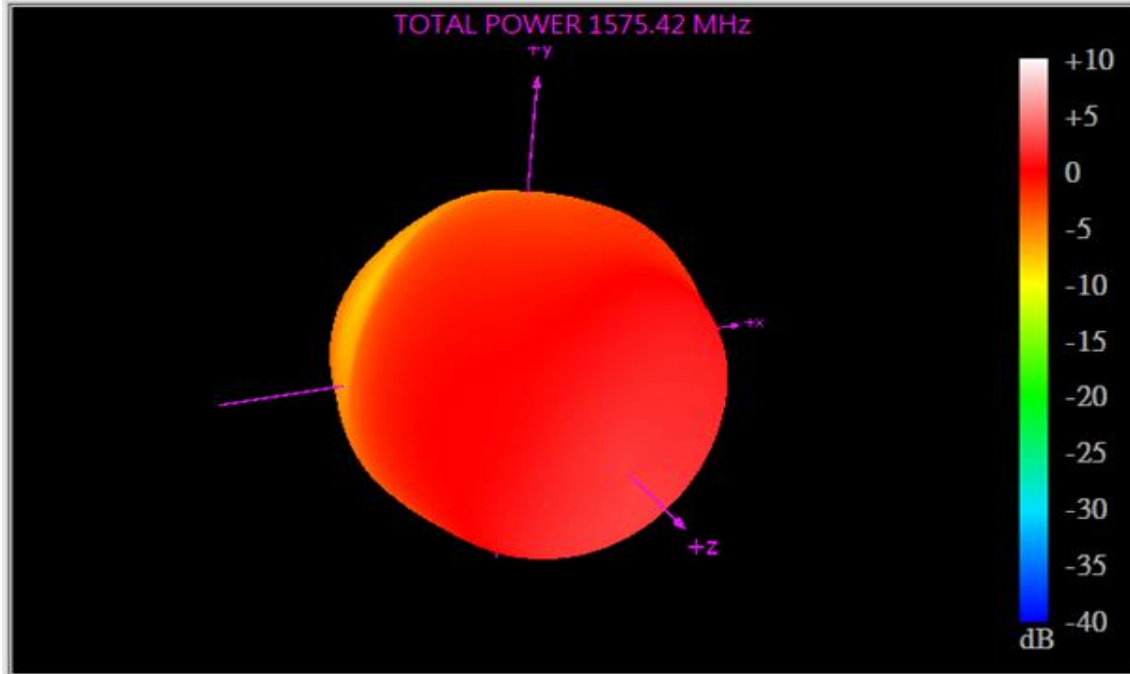

6. Mechanical Drawing (Units: mm)

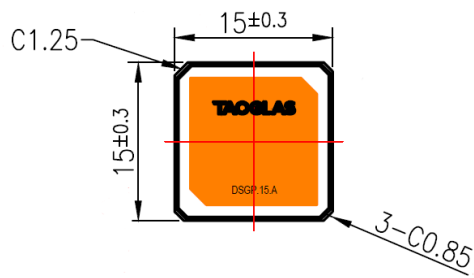

Top View

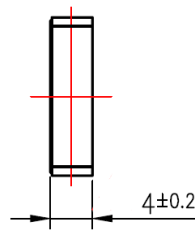

Side View

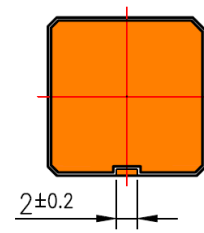

Bottom View

7. Antenna Integration Guide



7.1 Schematic Symbol and Pin Definition

The circuit symbol for the antenna is shown below. The antenna has 9 pins as indicated below.

Pin	Description
1	RF Feed
2, 3, 4, 5, 6, 7, 8, 9	Ground

TAOGLAS_DSGP.1575.15.4.A.02
ANTI

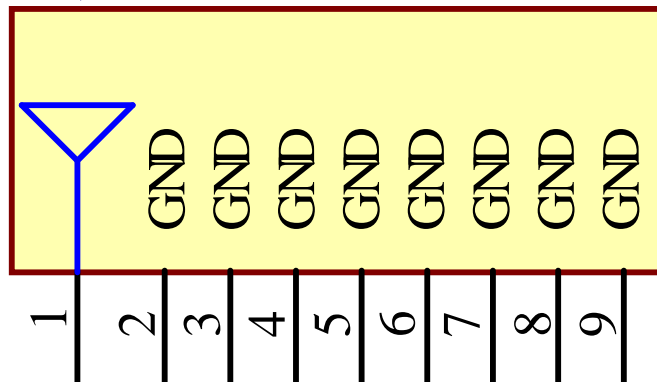

7.2 Antenna Integration

The antenna should be placed at the center of the ground plane with a length and width of 50mm. Maintaining a square symmetric ground plane shape and symmetric environment around the antenna is critical to maintaining the excellent axial ratio and phase center performance shown in this datasheet.



Top Side w/ Solder Mask



Top Side w/o Solder Mask

7.3 PCB Layout

The footprint and clearance on the PCB must comply with the antenna specification. The PCB layout shown in the diagram below demonstrates the antenna footprint.

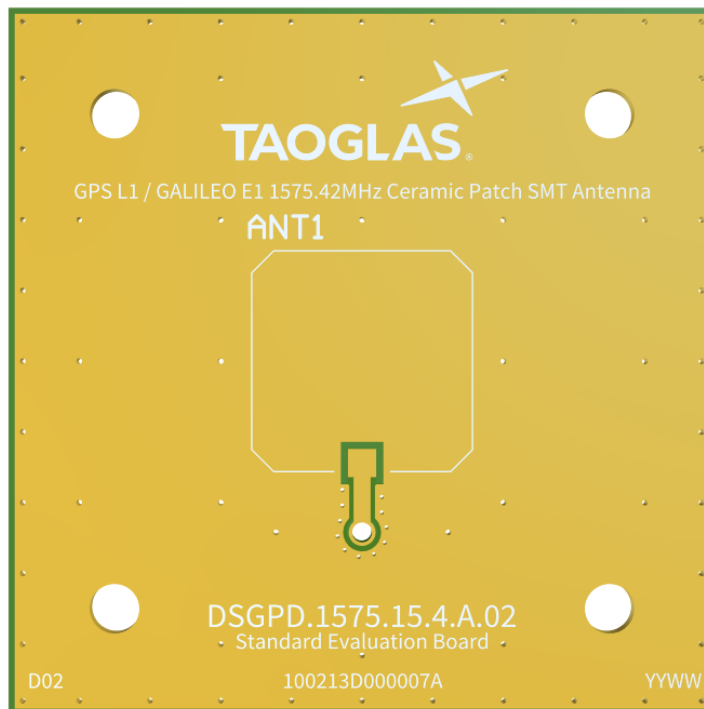

Topside

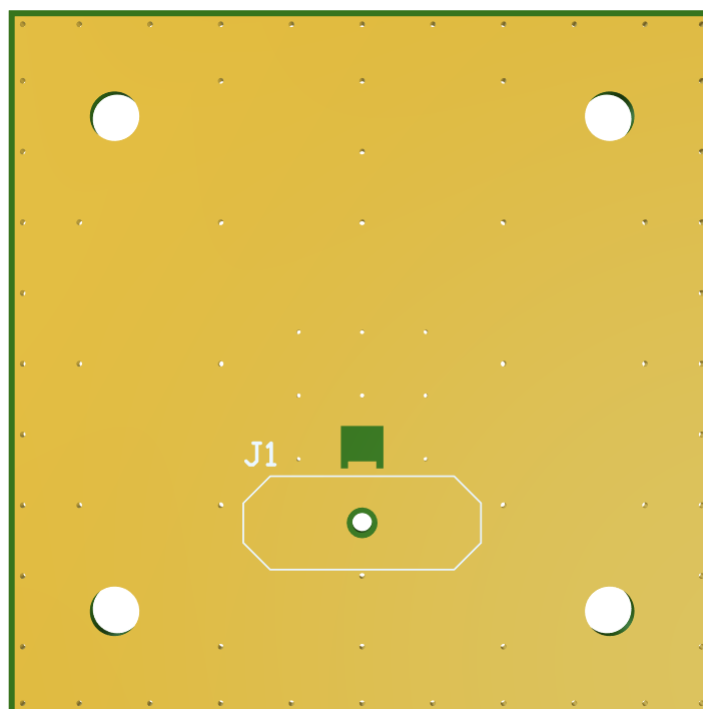

Bottom Side

7.4 Evaluation Board



Topside

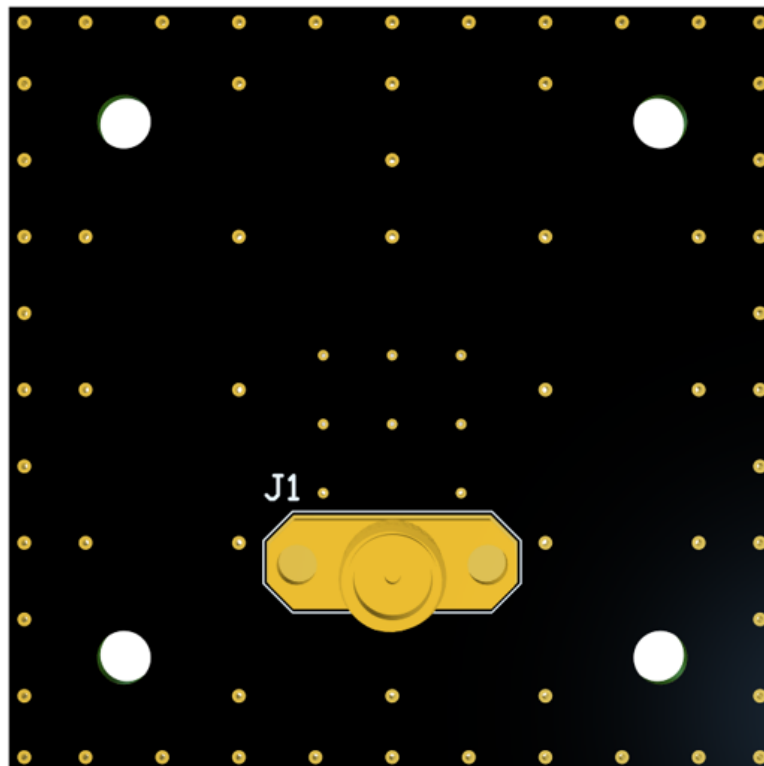

Bottom Side

7. Evaluation Board Mechanical Drawing

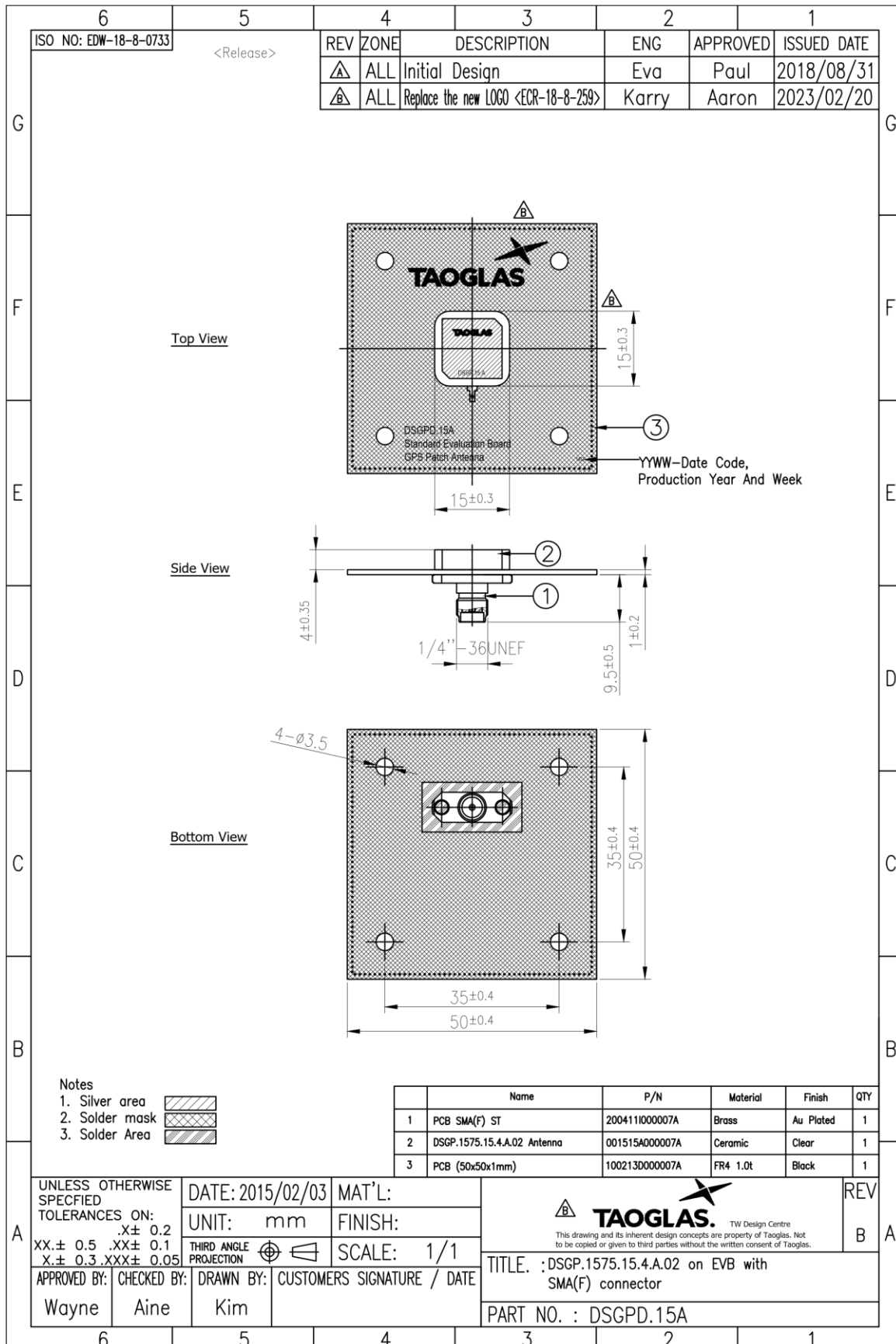

8. PCB Footprint Recommendation

8.1 Footprint Copper Keepout Area (Unit: mm)

Pads 2, 4, 5, 6 are the same size

Pads 1, 2, 3, 4, 5, 6, 7 and 9 should be connected to GND.

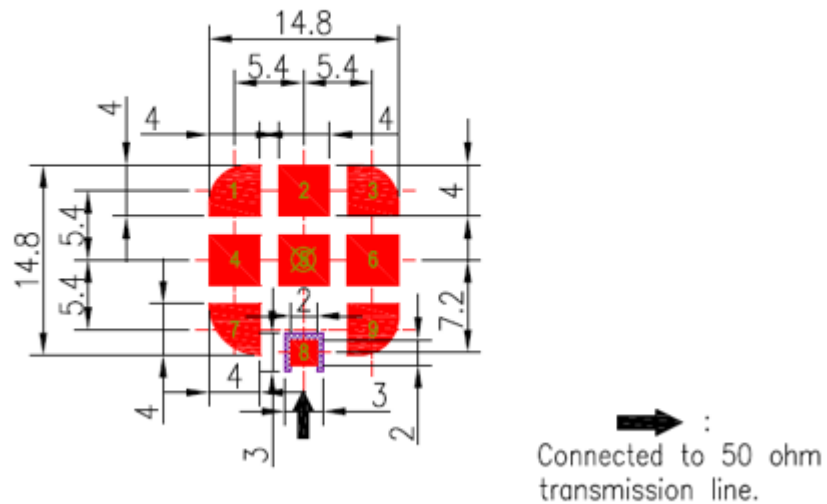

8.2 Paste Area (Unit: mm)

Pads 2, 4, 5, 6, are the same size.

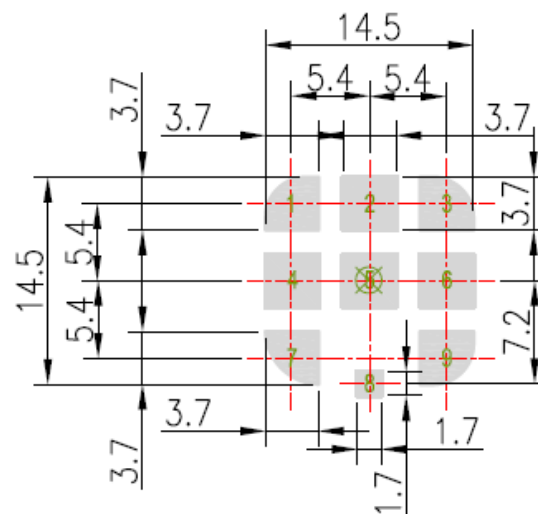

8.3 Top Solder Mask (Unit: mm)

Pads 2, 4, 5, 6, are the same size.



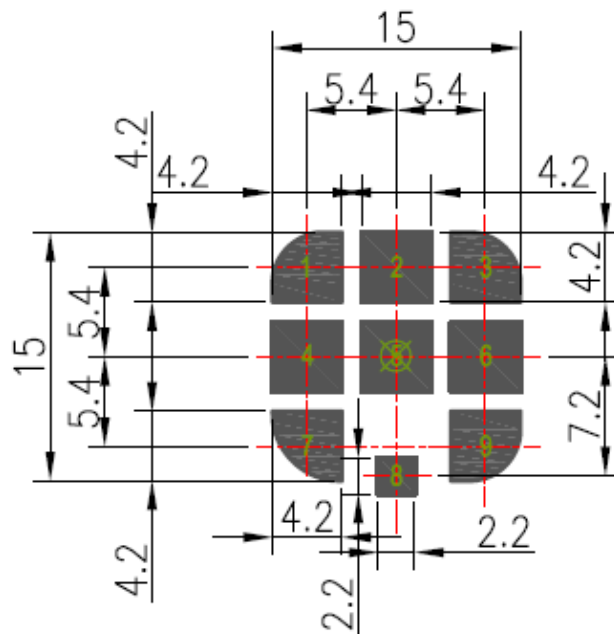

This drawing is a negative of solder mask. Black regions are anti-mask.

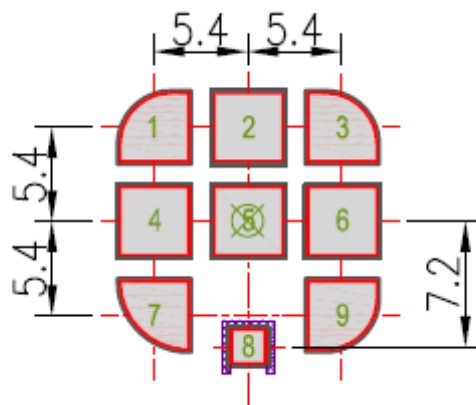

8.4 Composite Diagram (Unit: mm)



NOTE:

- 1. Ag Plated area 
- 2. Solder Mask area 
- 3. Copper area 
- 4. Paste area 
- 5. Copper Keepout Area 

6. Copper keepout should extend through all PCB layers.

7. Any vias in pads should be either filled or tented to prevent solder from wicking away from the pad during reflow.

8. The dimension tolerances should follow standard PCB manufacturing guidelines

9. Packaging

200 pc DSGP.1575.15.4.A.02 per reel
 Dimensions - Ø330*36.4mm
 Weight - 1.34Kg

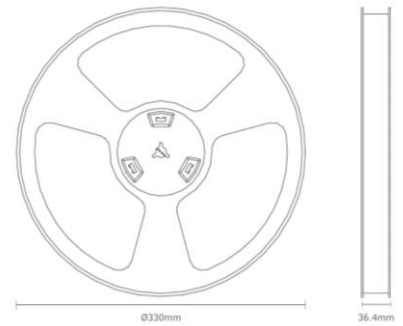

1 pc reel Per Small Inner Carton
 Dimensions - 360*360*70mm
 Weight - 1.6Kg

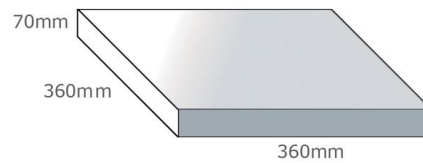

4 Reels / 800 pcs in one carton
 Carton Dimensions - 380*380*300mm
 Weight - 7.5Kg

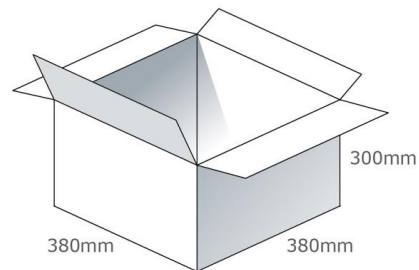

Pallet Dimensions 1100*1100*1270mm
 24 Cartons per Pallet
 6 Cartons per layer
 4 Layers

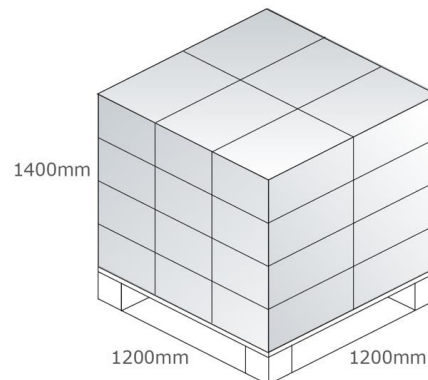

Changelog for the datasheet

SPE-18-058-DSGP.1575.15.4.A.02

Revision: C (Current Version)	
Date:	2023-02-28
Changes:	Antenna Integration Guide Added
Changes Made by:	Cesar Sousa

Previous Revisions

Revision: B	
Date:	2021-06-12
Changes:	Updated Specifications
Changes Made by:	Technical Writer

Revision: A (Original First Release)	
Date:	2018-05-17
Notes:	
Author:	Technical Writer



TAOGLAS®

www.taoglas.com

