



Part Number: DHI2060

Electrical Specifications

Frequency Range (GHz):	2.0 – 6.0
Isolation (dB):	14 MIN
Insertion Loss (dB):	0.8 MAX
VSWR:	1.5:1 MIN
Forward Power (W):	20 AVG 30 PK
Reflective Power (W):	2 AVG

Mechanical/Environmental Specifications

Connector Type:	SMA
Connector Body:	Passivated stainless steel
Connector Pin:	Gold plated copper
Load Body:	Brass
Magnetic Shunt:	Nickel plated CRS
External Coating:	Epoxy
Operational Temp:	0°C to +50°C
Weight (oz):	3.5 MAX
Humidity:	> 95% RH
Vibration:	20grms
Shock:	20g pk
Altitude:	> 50kft
Screening Test:	Non-Operational Thermal Cycles
ATP:	Operational thermal cycling

Test Report Included w/CofC. To customize test procedures or specifications to your requirements, please contact DiTom.

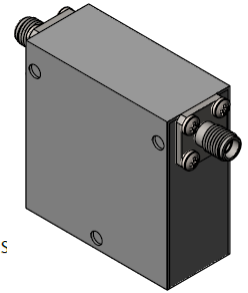

DHI2060 Dimensions

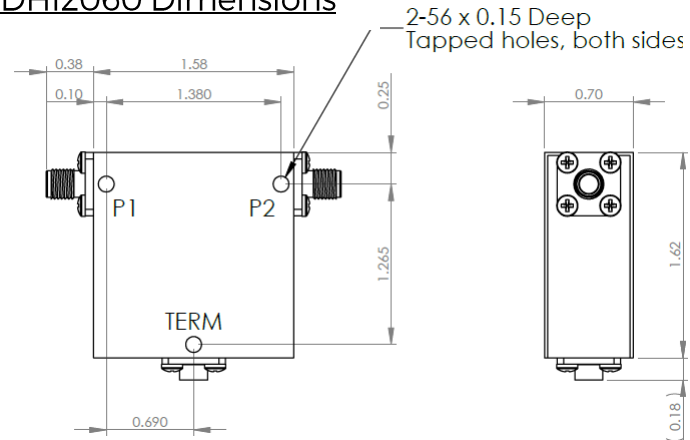

DHI2060-3 Dimensions

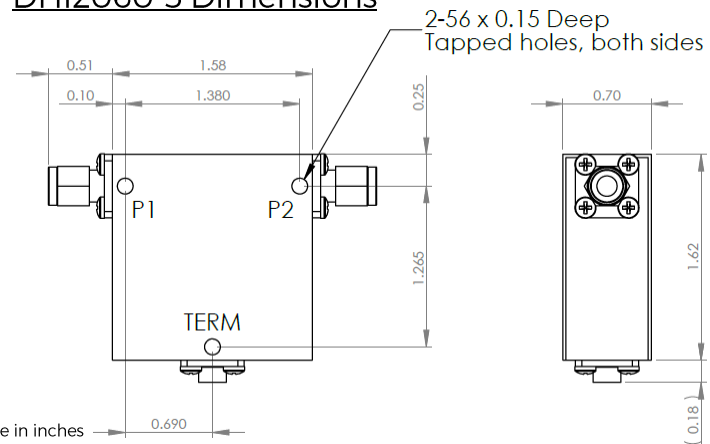

Dimensions are in inches
Tolerance
XX ±0.03
XXX ±0.010

Type of Device	PN Suffix	Connector Configuration Input / Output	PN Example
Single and Dual Junction Isolator, 2-Port Device	N/A	Female / Female	DHI2060
	-1	Male / Female	DHI2060-1
	-2	Female / Male	DHI2060-2
	-3	Male / Male	DHI2060-3



MEASURED DATA

Part Number: DHI2060, +25°C

