

DA-QFN32-6X6P65

QFN-32 TO DIP ADAPTER – 6mm x 6mm – P0.65

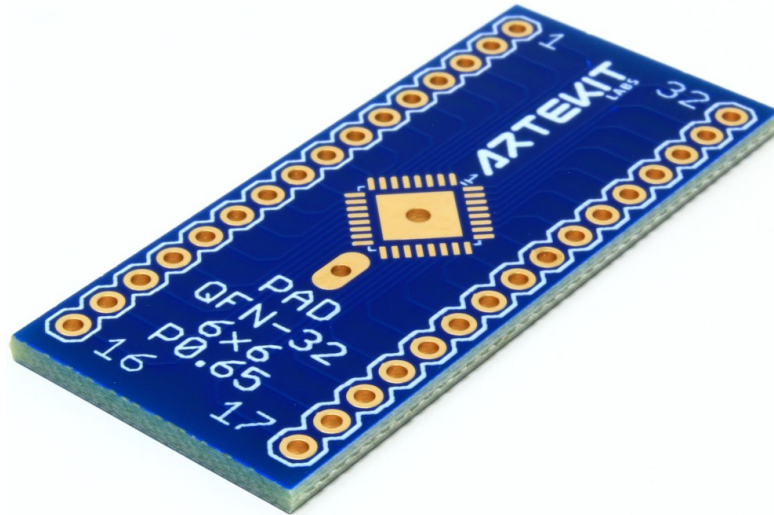

This adapter breaks out the pins of a QFN-32 component (with a body of 6mm x 6mm and 0.65mm pin pitch) into a board with 0.1" (2.54mm) spaced pins.

This is a high quality PCB, with all the copper pads and contacts plated with Electroless Nickel Immersion Gold (ENIG) process, offering an excellent surface planarity and oxidation resistance.

The land pattern includes a solderable exposed pad that is present in many QFN-32 components, to increase the maximum power dissipation (can be used to dissipate heat from a high-power integrated circuit like a motor controller or an audio amplifier). There is a hole drilled through the exposed pad on the PCB that can be used to drop some solder and ensure conductivity and heat dissipation from the PCB up to the integrated circuit. Since the exposed pad is often connected to GND, the exposed pad is also connected to a dedicated outer pad, allowing to eventually wire a connection to it.

Specifications	
Supported packages	QFN-32
Package body size	6mm x 6mm
Component pin pitch	0.65mm
Board pin pitch	2.54mm (0.1")
Temperature rating	-25°C to +125°C
Material	FR4
RoHS compliant	Yes

Board dimensions

All dimensions are in millimeters

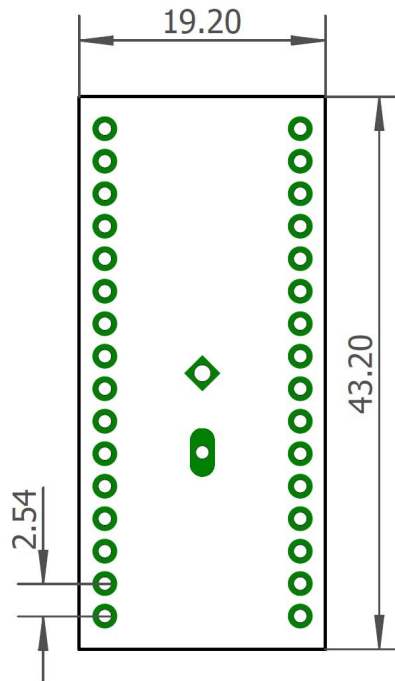

Land pattern dimensions

All dimensions are in millimeters

