

ISS.	AMEND	DATE
1		11/05/18
2	ISSUED ST REVERSED	27/09/22

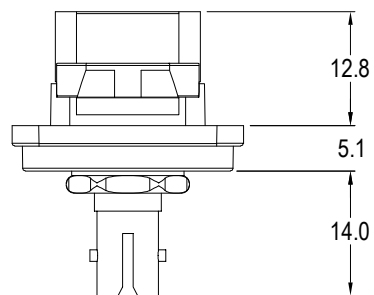
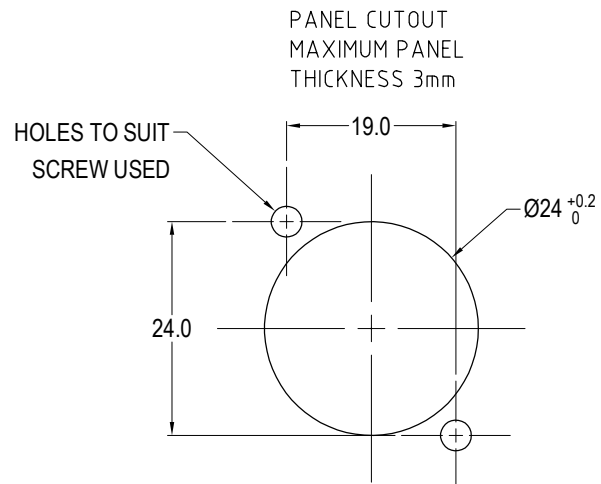

**Material:**

1. Insert: ABS UL94 HB
2. Frame: Nickel plated zinc diecast
3. ST Contacts: Nickel Plated

VARIANTS	
PART NO.	HOLE DETAILS
CP30218M	HOLE Ø3.50 X CSK 82° X Ø5.85
CP30218M3	M3 HOLES

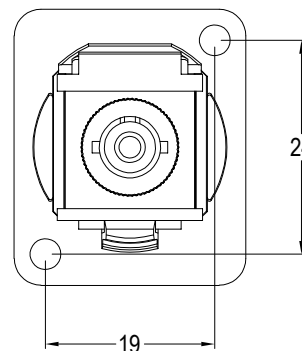
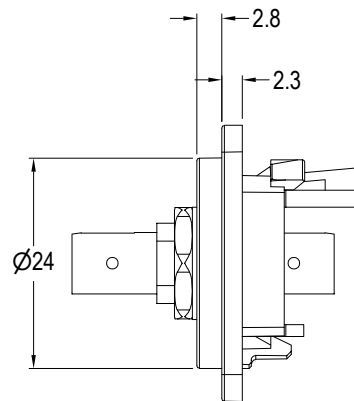
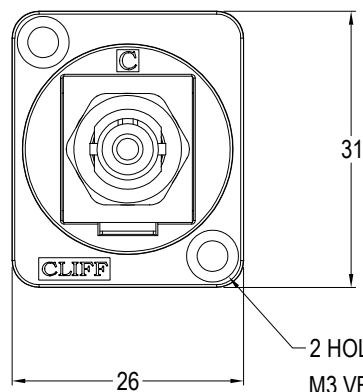

2 HOLES: Ø3.5mm CSK 82° x Ø5.85  
M3 VERSION HAS M3 THREAD HOLES.

**RoHS**  
COMPLIANT

**TOLERANCE**  
NO DEC. PLACE ±  
1 DEC. PLACE ±  
2 DEC. PLACE ±  
HOLE Ø ±  
ANGLES ±  
UNLESS  
OTHERWISE STATED

DO NOT SCALE

**Cliff Electronic Components Ltd.**

76 Holmethorpe Avenue, Holmethorpe Industrial Estate,  
Redhill, Surrey, RH1 2PF, England, UK  
Tel: 01737-771375 Fax: 01737-766012 Website: www.cliffuk.co.uk

DIMENSIONS IN MILLIMETERS UNLESS OTHERWISE STATED. WORK TO DIMENSIONS. REMOVE ALL BURRS. IF IN DOUBT ASK.

3rd ANGLE PROJECTION:

MATERIAL: See Notes

FINISH: See Notes

DRAWN: T.J.O.

APPROVED: D.P.J.

TITLE: METAL FEED THROUGH ST FIBRE

DRWG. No. CP30218M

FORM: A4DRWGH