

# CMPX Series

Metallized Polypropylene Film Capacitors  
Interference Suppressors Class – X2

**TRIGON**  
COMPONENTS

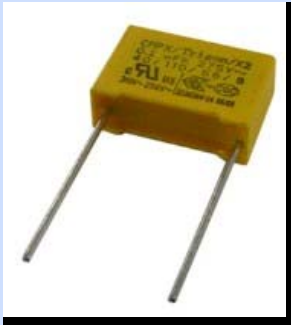

**Configuration:**

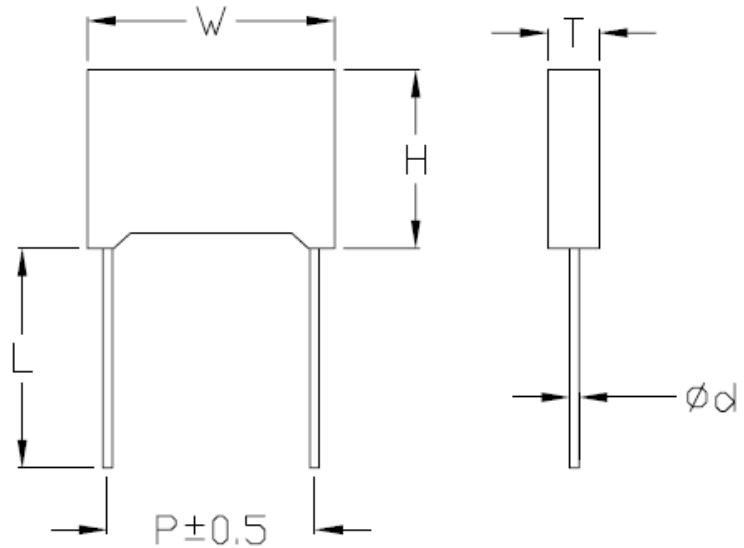

## FEATURES

- Self-healing property.
- High moisture resistance.
- Overvoltage stress withstanding.
- UL/CSA and European safety regulations class X2 (meeting EN132400 1994/IEC384-14 2<sup>nd</sup> 1993).
- Flame retardant plastic case and epoxy resin (UL-class 94V-0).
- Meet Standards Of:  
VDE, ENEC, CE, UL, CE, CQC.
- UL File Name: E197459
- RoHS Compliant.

## APPLICATIONS

They are ideal for line-by-pass, across-the-line, antenna coupling, spark killer circuits, switching power supply and available for EMI filter application.

## ORDERING CODE

**CMPX 223 K 27A L 100 T -18x10x7**

- (1) (2) (3) (4) (5) (6) (7) (8)
- (1) Metallized Polypropylene Film Capacitor – Interference Suppressor Class –X2
  - (2) Capacitance Code
  - (3) Tolerance Code
  - (4) Rated Voltage Code
  - (5) Lead Style
  - (6) Lead Pitch
  - (7) Package
  - (8) Capacitor Dimension -WxHxT

※ please refer to complete Ordering Code document (CPMx-Ord) for more ordering options.

**Specification:**

Item	Performance Characteristics
Operating Temperature	-40°C ~ +110°C
Capacitance Range	0.0047 uF ~ 6.8 uF
Capacitance Tolerance	±10%(K), ±20%(M)
Rated Voltage (RV)	275V AC 50Hz~60Hz ( ENEC )
	310V AC 50Hz~60H ( UL1283 )
DISSIPATION FACTOR (DF)	0.1% max (at 1KHz, 25°C)
TESTING VOLTAGE (TV)	1185V DC For 60 Sec: Terminal-Terminal
	2000VAC For 60 Sec: Terminal-Body
Insulation Resistance (IR) (At 25°C 100±15VDC for 1 min)	$C \leq .33\mu\text{F}$ , $IR \geq 15000 \text{ M}\Omega$ , uF
	$C > .33\mu\text{F}$ , $IR \geq 5000 \text{ M}\Omega$ , uF

Capacitor

# CMPX Series

## Metallized Polypropylene Film Capacitors Interference Suppressors Class – X2

**TRIGON**  
COMPONENTS

### Dimension: (Table II)

CODE	RV	275 VAC								
	Size CAP (uF)	W (±0.5)	H (±0.5)	T (±0.5)	P (±0.5)	Φd (±0.05)	L (±2.0)	Bulk pcs/unit	Ammo pcs/unit	Reel pcs/unit
CMPX472K27AL100T-13X9X4	0.0047	13	9	4	10	0.6	20	N	N	N
CMPX472K27AL100T-13X11X5	0.0047	13	11	5	10	0.6	20	N	N	N
CMPX562K27AL100T-13X9X4	0.0056	13	9	4	10	0.6	20	N	N	N
CMPX562K27AL100T-13X11X5	0.0056	13	11	5	10	0.6	20	N	N	N
CMPX682K27AL100T-13X9X4	0.0068	13	9	4	10	0.6	20	N	N	N
CMPX682K27AL100T-13X11X5	0.0068	13	11	5	10	0.6	20	N	N	N
CMPX822K27AL100T-13X9X4	0.0082	13	9	4	10	0.6	20	N	N	N
CMPX822K27AL100T-13X11X5	0.0082	13	11	5	10	0.6	20	N	N	N
CMPX103K27AL100T-13X11X5	0.010	13	11	5	10	0.6	20	N	N	N
CMPX103K27AL150T-18X11X5	0.010	18	11	5	15	0.8	20	N	N	N
CMPX123K27AL150T-18X11X5	0.012	18	11	5	15	0.8	20	N	N	N
CMPX153K27AL100T-13X11X5	0.015	13	11	5	10	0.6	20	N	N	N
CMPX153K27AL150T-18X11X5	0.015	18	11	5	15	0.8	20	N	N	N
CMPX183K27AL100T-13X11X5	0.018	13	11	5	10	0.6	20	N	N	N
CMPX183K27AL150T-18X11X5	0.018	18	11	5	15	0.8	20	N	N	N
CMPX223K27AL100T-13X11X5	0.022	13	11	5	10	0.6	20	N	N	N
CMPX223K27AL150T-18X11X5	0.022	18	11	5	15	0.8	20	N	N	N
CMPX273K27AL100T-13X11X5	0.027	13	11	5	10	0.6	20	N	N	N
CMPX273K27AL150T-18X11X5	0.027	18	11	5	15	0.8	20	N	N	N
CMPX333K27AL100T-13X11X5	0.033	13	11	5	10	0.6	20	N	N	N
CMPX333K27AL150T-18X11X5	0.033	18	11	5	15	0.8	20	N	N	N
CMPX393K27AL100T-13X11X5	0.039	13	11	5	10	0.6	20	N	N	N
CMPX393K27AL150T-18X11X5	0.039	18	11	5	15	0.8	20	N	N	N
CMPX473K27AL100T-13X11X5	0.047	13	11	5	10	0.6	20	N	N	N
CMPX473K27AL150T-18X11X5	0.047	18	11	5	15	0.8	20	N	N	N
CMPX563K27AL100T-13X11X5	0.056	13	11	5	10	0.6	20	N	N	N
CMPX563K27AL150T-18X11X5	0.056	18	11	5	15	0.8	20	N	N	N
CMPX683K27AL100T-13X12X6	0.068	13	12	6	10	0.6	20	N	N	N
CMPX683K27AL150T-18X11X5	0.068	18	11	5	15	0.8	20	N	N	N
CMPX683K27AL150T-18X12X6	0.068	18	12	6	15	0.8	20	N	N	N
CMPX823K27AL100T-13X12X6	0.082	13	12	6	10	0.6	20	N	N	N
CMPX823K27AL150T-18X11X5	0.082	18	11	5	15	0.8	20	N	N	N

Capacitor

- ※ Lead Length Can be design as customer requirement
- ※ Large sizes available upon request

# CMPX Series

## Metallized Polypropylene Film Capacitors Interference Suppressors Class – X2

**TRIGON**  
COMPONENTS

### Dimension: (Table II)

CODE	RV	275 VAC								
	Size	W	H	T	P	Φd	L	Bulk	Ammo	Reel
	CAP (uF)	(±0.5)	(±0.5)	(±0.5)	(±0.5)	(±0.05)	(±2.0)	pcs/unit	pcs/unit	pcs/unit
CMPX104K27AL100T-13X12X6	0.10	13	12	6	10	0.6	20	N	N	N
CMPX104K27AL150T-18X11X5	0.10	18	11	5	15	0.8	20	N	N	N
CMPX104K27AL150T-18X12X6	0.10	18	12	6	15	0.8	20	N	N	N
CMPX124K27AL150T-18X11X5	0.12	18	11	5	15	0.8	20	N	N	N
CMPX124K27AL150T-18X12X6	0.12	18	12	6	15	0.8	20	N	N	N
CMPX124K27AL150T-18X13.5X7.5	0.12	18	13.5	7.5	15	0.8	20	N	N	N
CMPX154K27AL100T-13X14X8	0.15	13	14	8	10	0.6	20	N	N	N
CMPX154K27AL150T-18X12X6	0.15	18	12	6	15	0.8	20	N	N	N
CMPX154K27AL150T-18X13.5X7.5	0.15	18	13.5	7.5	15	0.8	20	N	N	N
CMPX154K27AL150T-18X14.5X8.5	0.15	18	14.5	8.5	15	0.8	20	N	N	N
CMPX154K27AL225T-26.5X15X6	0.15	26.5	15	6	22.5	0.8	20	N	N	N
CMPX184K27AL150T-18X13.5X7.5	0.18	18	13.5	7.5	15	0.8	20	N	N	N
CMPX184K27AL150T-18X14.5X8.5	0.18	18	14.5	8.5	15	0.8	20	N	N	N
CMPX184K27AL225T-26.5X16X7	0.18	26.5	16	7	22.5	0.8	20	N	N	N
CMPX224K27AL150T-18X13X7	0.22	18	13	7	15	0.8	20	N	N	N
CMPX224K27AL150T-18X14.5X8.5	0.22	18	14.5	8.5	15	0.8	20	N	N	N
CMPX224K27AL150T-18X15.5X9.5	0.22	18	15.5	9.5	15	0.8	20	N	N	N
CMPX224K27AL225T-26.5X15X6	0.22	26.5	15	6	22.5	0.8	20	N	N	N
CMPX224K27AL225T-26.5X16X7	0.22	26.5	16	7	22.5	0.8	20	N	N	N
CMPX274K27AL150T-18X14.5X8.5	0.27	18	14.5	8.5	15	0.8	20	N	N	N
CMPX274K27AL225T-26.5X17.5X8.5	0.27	26.5	17.5	8.5	22.5	0.8	20	N	N	N
CMPX334K27AL150T-18X15.5X8	0.33	18	15.5	8	15	0.8	20	N	N	N
CMPX334K27AL150T-18X15.5X9.5	0.33	18	15.5	9.5	15	0.8	20	N	N	N
CMPX334K27AL225T-26.5X16X7	0.33	26.5	16	7	22.5	0.8	20	N	N	N
CMPX334K27AL225T-26.5X17X8.5	0.33	26.5	17	8.5	22.5	0.8	20	N	N	N
CMPX394K27AL150T-18X19X11	0.39	18	19	11	15	0.8	20	N	N	N
CMPX394K27AL225T-26.5X19X10	0.39	26.5	19	10	22.5	0.8	20	N	N	N
CMPX474K27AL150T-18X18.5X7.5	0.47	18	18.5	7.5	15	0.8	20	N	N	N
CMPX474K27AL150T-18X16X10	0.47	18	16	10	15	0.8	20	N	N	N
CMPX474K27AL150T-18X19X11	0.47	18	19	11	15	0.8	20	N	N	N
CMPX474K27AL225T-26.5X16X7	0.47	26.5	16	7	22.5	0.8	20	N	N	N
CMPX474K27AL225T-26.5X17.5X8.5	0.47	26.5	17.5	8.5	22.5	0.8	20	N	N	N
CMPX474K27AL225T-26.5X19X10	0.47	26.5	19	10	22.5	0.8	20	N	N	N

Capacitor

- ※ Lead Length Can be design as customer requirement
- ※ Large sizes available upon request

# CMPX Series

## Metallized Polypropylene Film Capacitors Interference Suppressors Class – X2

**TRIGON**  
COMPONENTS

### Dimension: (Table II)

CODE	RV	275 VAC								
	Size	W (±0.5)	H (±0.5)	T (±0.5)	P (±0.5)	Φd (±0.05)	L (±2.0)	Bulk pcs/unit	Ammo pcs/unit	Reel pcs/unit
	CAP (uF)									
CMPX474K27AL275T-32X20X11	0.47	32	20	11	27.5	0.8	20	N	N	N
CMPX564K27AL150T-18X19X10	0.56	18	19	10	15	0.8	20	N	N	N
CMPX564K27AL225T-26.5X17.5X8.5	0.56	26.5	17.5	8.5	22.5	0.8	20	N	N	N
CMPX564K27AL275T-32X20X11	0.56	32	20	11	27.5	0.8	20	N	N	N
CMPX684K27AL150T-18X19.5X11	0.68	18	19.5	11	15	0.8	20	N	N	N
CMPX684K27AL225T-26.5X19X10	0.68	26.5	19	10	22.5	0.8	20	N	N	N
CMPX684K27AL275T-32X20X11	0.68	32	20	11	27.5	0.8	20	N	N	N
CMPX824K27AL150T-18X21X12	0.82	18	21	12	15	0.8	20	N	N	N
CMPX824K27AL225T-26.5X19X10	0.82	26.5	19	10	22.5	0.8	20	N	N	N
CMPX824K27AL225T-26.5X21.5X12	0.82	26.5	21.5	12	22.5	0.8	20	N	N	N
CMPX824K27AL275T-32X22X13	0.82	32	22	13	27.5	0.8	20	N	N	N
CMPX105K27AL225T-26.5X19X10	1.0	26.5	19	10	22.5	0.8	20	N	N	N
CMPX105K27AL225T-26.5X21.5X12	1.0	26.5	21.5	12	22.5	0.8	20	N	N	N
CMPX105K27AL275T-32X22X13	1.0	32	22	13	27.5	0.8	20	N	N	N
CMPX125K27AL315T-37X24X13.5	1.2	37	24	13.5	31.5	0.8	20	N	N	N
CMPX125K27AL275T-32X22X13	1.2	32	22	13	27.5	0.8	20	N	N	N
CMPX155K27AL315T-37X26.5X16	1.5	37	26.5	16	31.5	0.8	20	N	N	N
CMPX185K27AL315T-37X26.5X16	1.8	37	26.5	16	31.5	0.8	20	N	N	N
CMPX225K27AL315T-37X26.5X16	2.2	37	26.5	16	31.5	0.8	20	N	N	N
CMPX225K27AL315T-37X24X13.5	2.2	37	24	13.5	31.5	0.8	20	N	N	N
CMPX225K27AL275T-32X24.5X14	2.2	32	24.5	14	27.5	0.8	20	N	N	N
CMPX275K27AL315T-37X28.5X18	2.7	37	28.5	18	31.5	0.8	20	N	N	N
CMPX335K27AL315T-37X34X22	3.3	37	34	22	31.5	0.8	20	N	N	N
CMPX335K27AL275T-32X33X18	3.3	32	33	18	27.5	0.8	20	N	N	N
CMPX335K27AL315T-37X28.5X18	3.3	37	28.5	18	31.5	0.8	20	N	N	N
CMPX335K27AL465T-51X27.5X17.5	3.3	51	27.5	17.5	46.5	0.8	20	N	N	N
CMPX395K27AL465T-51X27.5X17.5	3.9	51	27.5	17.5	46.5	0.8	20	N	N	N
CMPX475K27AL465T-51X30.5X20	4.7	51	30.5	20	46.5	0.8	20	N	N	N
CMPX475K27AL375T-37X34X22	4.7	37	34	22	37.5	0.8	20	N	N	N
CMPX475K27AL275T-32X37X22	4.7	32	37	22	27.5	0.8	20	N	N	N
CMPX685K27AL465T-51X35X24	6.8	51	35	24	46.5	0.8	20	N	N	N

Capacitor

- ※ Lead Length Can be design as customer requirement
- ※ Large sizes available upon request

# CMPX Series

**Metallized Polypropylene Film Capacitors  
Interference Suppressors Class – X2**

**TRIGON**  
COMPONENTS

## ELECTRICAL CHARACTERISTIC: (TABLE I)

NO	ITEM		SPECIFICATION	TEST METHODS
1.	Operating Temperature Range		-40°C ~ +110°C.	---
2.	Capacitance Range		0.0047 uF ~ 6.8 uF.	7 -- 3
3.	Capacitance Tolerance		±10% (K), ±20% (M).	7 -- 3
4.	Rated Voltage (RV)		275VAC (ENEC), 310VAC (UL1283).	---
5.	Performance Class		X2.	---
6.	Climatic Category		40 / 110 / 56.	---
7.	Passive Flammability Category		B (According to EN60384 -14:2005.)	---
8.	Plastic Case		Qualified Accordance with UL94V-0.	---
9.	Epoxy Resin Sealing		Qualified Accordance with UL94V-0.	---
10.	Reference IEC/EN Specification		IEC 60384 – 14:2005 (Ed3). EN 60384 – 14:2005.	---
11.	Testing Voltage(TV)	Terminal-Terminal	1185 VDC 60 sec. (or 2000VDC 1 sec).	7 -- 1
		Terminal-Body	2000 vac for 60 sec.	
12.	Insulation Resistance(IR) (at 25°C 100±15VDC for 1 min.)		C ≤ 0.33 uF, IR ≥ 15,000MΩ. uF C > 0.33 uF, IR ≥ 5,000 MΩ. uF	7 -- 2
13.	Dissipation Factor (DF) (at 25°C 1KHz)		≤ 0.1%	7 -- 4

# CMPX Series

Metallized Polypropylene Film Capacitors  
Interference Suppressors Class – X2

**TRIGON**  
COMPONENTS

## ELECTRICAL CHARACTERISTIC: (TABLE I)

NO	ITEM	SPECIFICATION		TEST METHODS
14.	Lead Pull Test	Lead Diameter	Pulling Load(Kgf)	7 -- 5
		0.6 mm	1.0kgf / 10±1s	
		0.8 mm	1.0kgf / 10±1s	
15.	Lead Bend Test	Lead Diameter	Pulling Load(Kgf)	7 -- 6
		0.6 mm	1.0kgf / 10±1s	
		0.8 mm	1.0kgf / 10±1s	
16.	Solderability Test	Condition: 260±5°C, 2±0.5sec.		7 -- 7
		Covered 95% by a continuous fresh solder coating		
17.	Heat Shock Test	Condition	260±5°C, 10±1sec.	7 -- 8
		Cap. Drift	±1% MAX.	
		DF	0.1% MAX.	
		IR	C ≤ 0.33 uF, IR = 15,000MΩ. uF MIN. C > 0.33 uF, IR = 5,000ΩF. uF MIN.	
18.	High Temperature Test	Condition	110 + 3 -0°C.	7 -- 10
		Cap. Drift	+ 0 – 5%.	
		DF	≤ 0.1%	
		IR	C ≤ 0.33 uF, IR = 18,000MΩ. uF MIN. C > 0.33 uF, IR = 600ΩF. uF MIN.	
19.	Low Temperature Test	Condition	-40 + 0 -3°C.	7 -- 11
		Cap. Drift	- 0 + 5%.	
		DF	≤ 0.15%.	
20.	Load Humidity Test	Condition	40°C ±2°C, R.H. 90 ~ 95%, 275 VAC / 60 Hz, 1344+24-0 hrs.	7 -- 12
		Cap. Drift	±5% MAX.	
		DF	≤ 0.2%.	
		IR	C ≤ 0.33 uF, IR ≥ 7,500MΩ. uF C > 0.33 uF, IR ≥ 2,500 MΩ. uF	
		TV	66% of the test voltage values.	
21.	Load Life Test	Condition	110±3°C, 344 VAC / 60Hz, 1008+48-0 hrs. with 1000 VAC / 60 Hz,0.1sec./hr applied.	7 -- 13
		Cap. Drift	±10% MAX.	
		DF	≤0.125%.	
		IR	C ≤ 0.33 uF, IR ≥ 7,500MΩ. uF C > 0.33 uF, IR ≥ 2,500 MΩ. uF	
		TV	66% of the test voltage values.	

Capacitor

# CMPX Series

## Metallized Polypropylene Film Capacitors Interference Suppressors Class – X2

1. **Suitability** The specification specified the construction, dimension and electrical characteristics of Trigon’s radio interference suppression capacitors type CMPX, for the use of across-the –line, antenna-coupling, EMI filter, spark killer and line-by-pass circuits where safety requirements are critical.

### 2. Construction

- 2-1 Metallized polypropylene film as its dielectric material.
- 2-2 Lead is Tin-coated annealed copper-ply wire.
- 2-3 High safety UL 94V-0 class fire retardant material applied on plastic case and epoxy resin.
- 2-4 Lead wire is electrically welded to the electrode.
- 2-5 Non-Inductive construction.

3. **Dimension** Shown as TABLE II.

4. **Approvals / Ref. documents** FOWX2.E197459.

5. **Designation** The designation shall consist of four constituent parts as illustrated below:

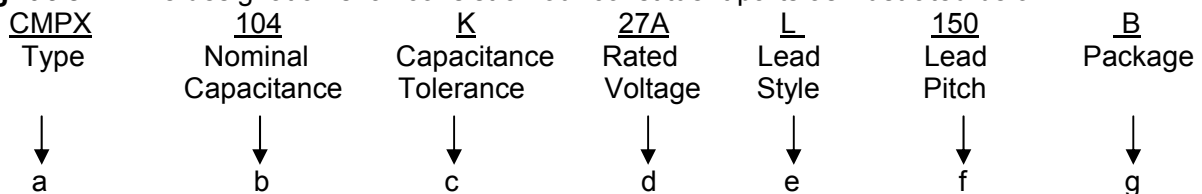

- 5-1 a. The type of CMPX, indicate metallized polypropylene capacitor and non-inductive construction.
- 5-2 b. The nominal capacitance is described by three digits; the first and second digits are the first and second significant figures of the nominal capacitance expressed in pF. The third sight states the number of zeros following the two significant figures.  
Example: 104 indicates 100000PF or 0.1uF
- 5-3 c. The indication symbols of capacitance tolerance are shown in TABLE III.
- 5-4 d. The indication symbols of rated voltage are shown in TABLE IV.
- 5-5 e. The indication symbols of lead type are shown in TABLE V.
- 5-6 f. The indication symbols of lead pitch are shown in TABLE VI.
- 5-7 g. Package: “B” for Bulk, “A” for Ammo, “T” for Tape & Reel.

TABLE III

SYMBOL	TOLERANCE
K	±10%
M	±20%

TABLE IV

SYMBOL	RATED VOLTAGE
27A	275 VAC

TABLE V

SYMBOL	LEAD FORMING
L	Straight
Y	Equidistant Forming
F	Pin Pitch Reduce/Enlarge Forming

TABLE VI

SYMBOL	LEAD PITCH
100	10.0±0.5mm
150	15.0±0.5mm
225	22.5±0.5mm
275	27.5±0.5mm

# CMPX Series

## Metallized Polypropylene Film Capacitors Interference Suppressors Class – X2

TRIGON  
COMPONENTS

6. **Marking** Marking of capacitors must be legible, correct, and consist of the following items.

- 6-1 a. Type of the capacitors CMPX.
- 6-2 b. Trade mark Trigon indication TRIGON Company.
- 6-3 c. Nominal capacitance in uF, such as 0.1.
- 6-4 d. Symbol of capacitance tolerance, such as K.
- 6-5 e. Rated Voltage in AC volts, such as 275~.
- 6-6 f. Capacitors class, such as X2.
- 6-7 g. Climatic category, such as 40/110/56/B.
- 6-8 h. Date code. (shown as note)
- 6-9 i. Recognized approval mark.

Note: Date Code:

The date code is described by four digits, the first and second digit is month, the third and fourth digits are year.

Example: date code 04 / 07      Month = 04, Year = 2007

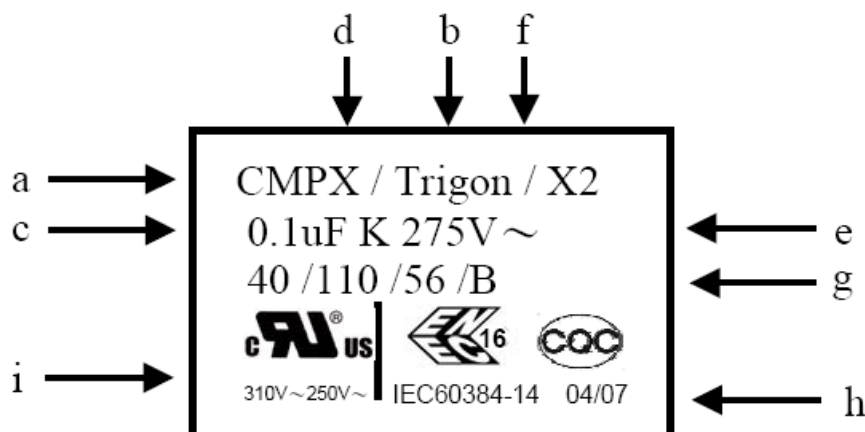

## 7. Testing Methods

- 7-1 **Testing Voltage Test** Capacitors shall comply with specified in TABLE I, that is starting at zero and increased in the rate of 100V / sec, applied between the terminals and between both terminals connected together and outer body, the test result must without permanent breakdown. The testing voltage of terminal-body shown as Fig III metal small ball method.
- 7-2 **IR Test** IR shall not be less than that specified in TABLE I. Measurement shall be made at 100±15VDC, with a charging time of 1 minute and at 25°C.
- 7-3 **Capacitance** Capacitance shall be within tolerance when measured at 25°C and at 1 KHz.
- 7-4 **Dissipation Factor (DF)** DF shall not exceed specified in TABLE I when measured at 25°C and at 1 KHz.
- 7-5 **Lead Pull Test** The element of capacitor shall be fixed. Then the load shown in TABLE VII is applied gradually in the axial direction of terminals of the capacitor. It should sustain for 10±1 seconds and not fracture or break.



# CMPX Series

## Metallized Polypropylene Film Capacitors Interference Suppressors Class – X2

TRIGON  
COMPONENTS

TABLE VII

Lead Diameter (mm)	Pulling Load (Kgf)	Bending Load (Kg)
0.6, 0.8	1.0	0.5

- 7-6 **Lead Bend Test** The bend test shall consist of attaching the load shown in TABLE VII to the lead the rotating the capacitor 90 degrees from the direction of lead egress, then 180 degrees in the opposite direction, an then back to the starting point, 1 such cycle per seconds. The lead must sustain two such cycle without breaking or damaging to the capacitor or seal.
- 7-7 **Solderability Test** The lead wire to be soldered is immersed in the solder flux, immediately there after it is immersed into the melting solder ( $260\pm 5^{\circ}\text{C}$ ) for  $2\pm 0.5$  sec. and the element of capacitor shall be kept distance from the surface of solder 1.5 ~ 2.0mm shown as Fig. I.  
At the completion of the test, the immersed portion of lead wire shall be covered with at least 95% by a continuous fresh solder coating.
- 7-8 **Heat Shock Test** The lead of capacitor shall be immersed in the melting solder ( $260\pm 5^{\circ}\text{C}$ ) for  $10\pm 1$  sec. shown in Fig. I. At the completion of the test, it should be subjected to the 7-1 TV Test, 7-2 IR Test, and 7-3 Capacitance Test. The C, DF, IR, TV shall meet the requirement specified in TABLE I.
- 7-9 **Vibration Test** The capacitor shall be fixed at the vibration table by soldering shown as Fig II, vibrating it with the variable frequency cycle, 1 minute per cycle from 10 Hz to 55 Hz, and then 10Hz, and amplitude 1.5mm for 2 hours, in each of three mutually perpendicular directions for a total of 6 hours. After the test, inspect the contraction and appearance of the capacitor.
- 7-10 **High Temperature Resistance Test** Capacitors shall be placed in the temperature  $110\pm 3-0^{\circ}\text{C}$ . After reaching thermal stability, the capacitors shall be measured C, IR, and DF. The C, IR, and DF shall meet the requirement specified in TABLE I.
- 7-11 **Low Temperature Resistance Test** Capacitors shall be placed in the temperature  $-40\pm 3-0^{\circ}\text{C}$ . After reaching thermal stability, the capacitors shall be measured C and DF. The C and DF shall meet the requirement specified in TABLE I.
- 7-12 **Load Humidity Test** Capacitors shall be exposed to a relative humidity of 90 ~ 95% at  $40\pm 2^{\circ}\text{C}$ , Load voltage = RV for 1344+24-0 hours. Remove capacitors from chamber and wipe surface of the units dry of moisture and dry circulating air for 2 hours. Capacitors shall be measured C, IR, TV and DF. The C, IR, TV and DF shall meet the requirement specified in TABLE I.
- 7-13 **Load Life Test** At  $110\pm 3^{\circ}\text{C}$  applied the test with 344 VAC for 1008+48-0 hours. During this period, applied 0.1 sec. of 1000 VAC 60 Hz for each hour. After the test C, IR, TV and DF shall meet the requirement specified in TABLE I. One failure shall be permitted out of ten unit tested.

# CMPX Series

## Metallized Polypropylene Film Capacitors Interference Suppressors Class – X2

**TRIGON**  
COMPONENTS

### 8. Testing Equipment

8-1 C and DF	HP4284A MULTI-FREQUENCY LCR METER (Hewlett Packard, Japan).
8-2 Insulation Resistance (IR)	Super Megohmmeter Model SM-8215 (TOA, Japan).
8-3 Dielectric Strength Tester (TV)	Puncture Tester Model (5KV) 875 AZ (Kikusui, Japan). CH9072 HIPOT TEST (5KV) (Chwua, Taiwan).
8-4 Circumstance Test Chamber	H-TH-ISP-C (Holink, Taiwan).
8-5 Life Tester	Made by Trigon our self.
8-6 Tensile Strength Tester	Model HT-8115 (Hung ta, Taiwan).

### 9. Acceptable Quality Level (AQL)

AQL is according to MIL-STD-105D table, by lot outgoing inspection.

9-1 Aspect	AQL: 1.0
9-2 Dimension	AQL: 0.65
9-3 Electric Characteristics	AQL: 0.25 (includes C, DF)
	AQL: Zero Defects (includes TV, IR)
9-4 Mechanical Characteristics	AQL: 0.4

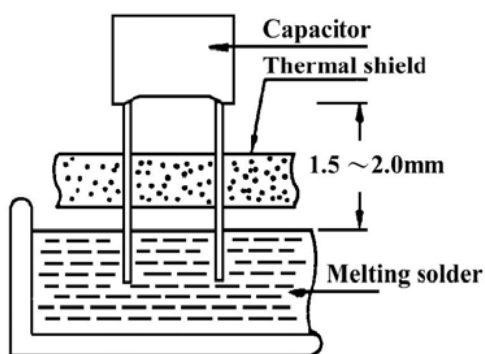

Fig I

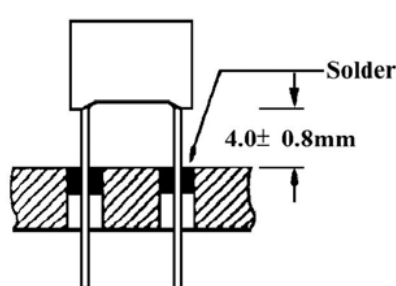

Fig II

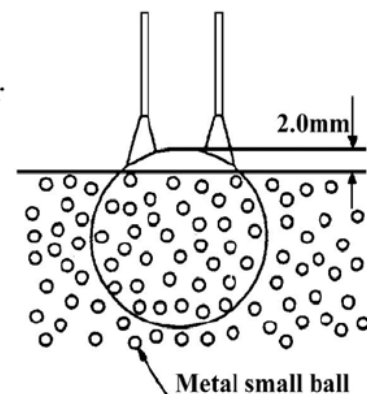

Fig III

# CMPX Series

Metallized Polypropylene Film Capacitors  
Interference Suppressors Class – X2

TRIGON  
COMPONENTS

Soldering Temperature Versus Time

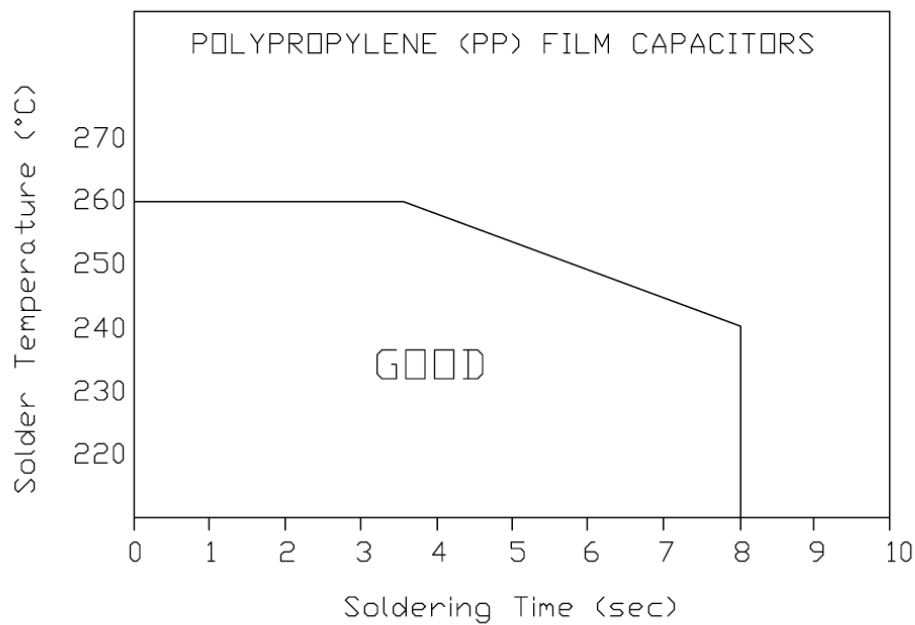

Soldering Temperature Versus Time

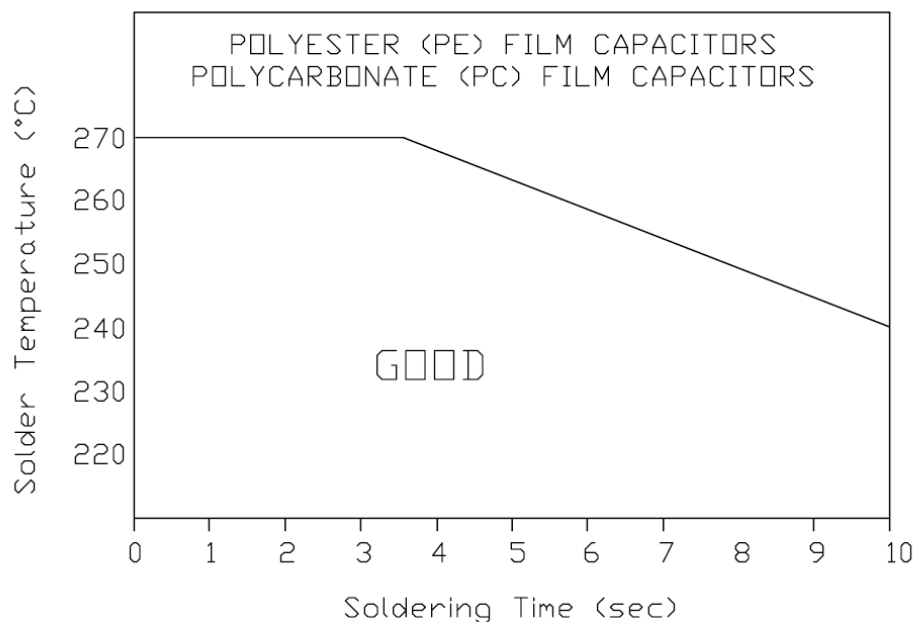

Pre-heating: 110°C 60sec.

Using soldering iron: below 350°C 5sec.

P.W Board: Through holes both sides  $\phi=0.8\text{mm}$  or more

Capacitor: Raised from P.W board (Processed products)

# CMPX Series

Metallized Polypropylene Film Capacitors  
Interference Suppressors Class – X2

**TRIGON**  
COMPONENTS

## ELECTRICAL CHARACTERISTIC CURVE:

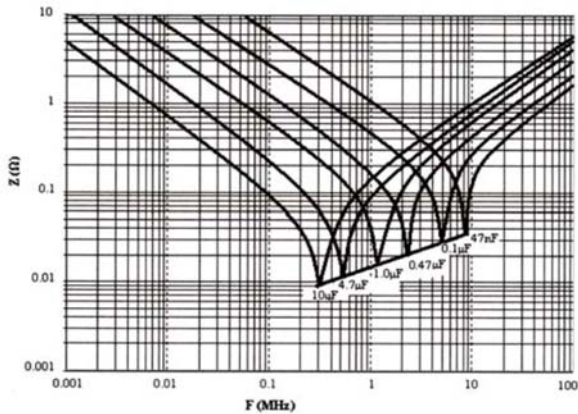

Impedance Versus Frequency

## ELECTRICAL CHARACTERISTIC CURVE:

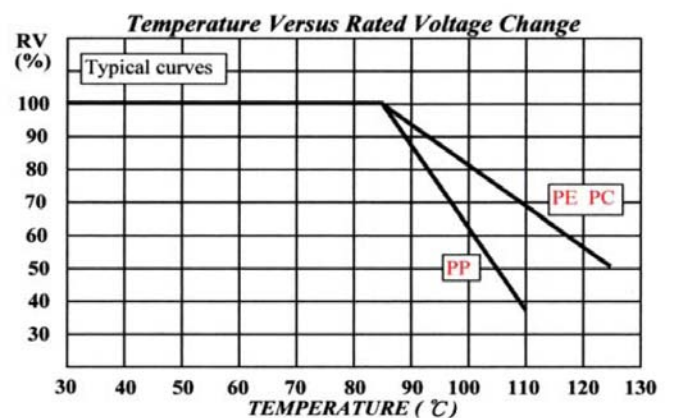
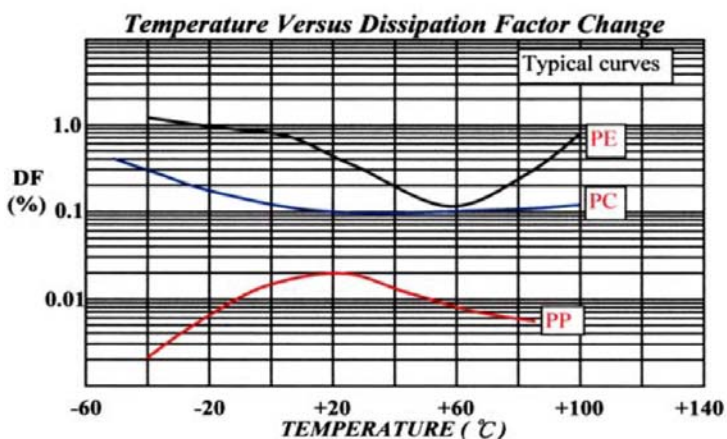
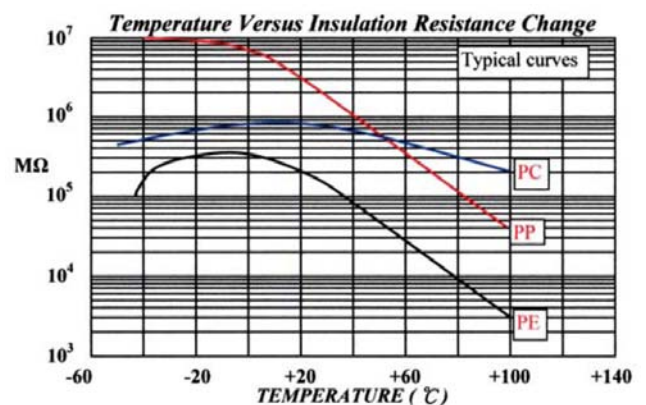
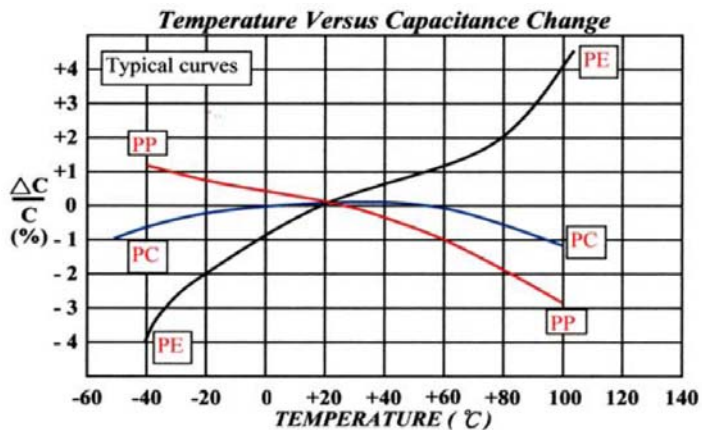

# CMPX Series

Metallized Polypropylene Film Capacitors  
Interference Suppressors Class – X2

TRIGON  
COMPONENTS

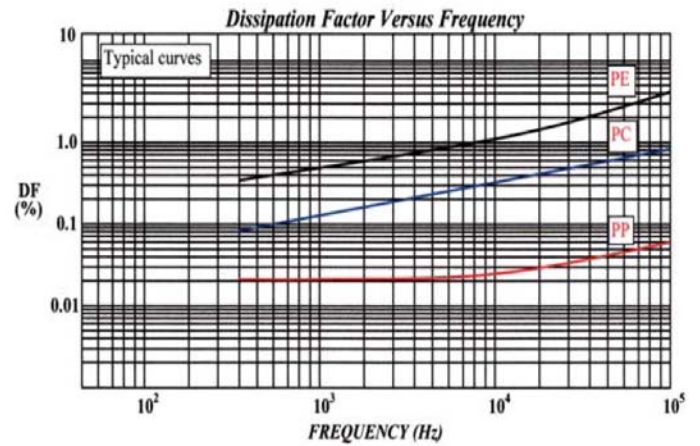
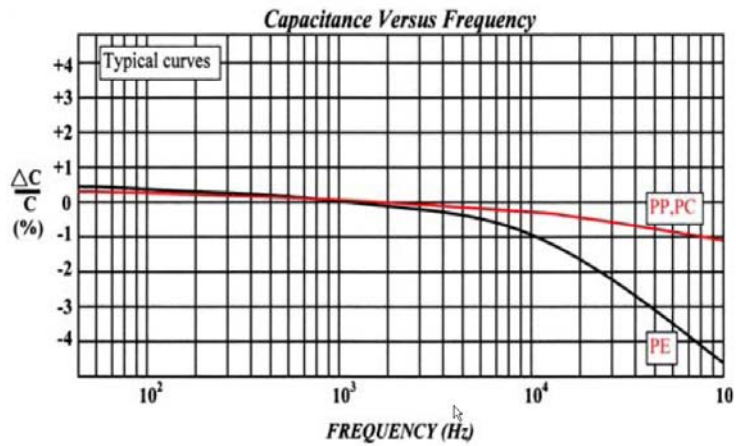

Capacitor

# CMPX Series

Metallized Polypropylene Film Capacitors  
Interference Suppressors Class – X2

**TRIGON**  
COMPONENTS

## Package Information:

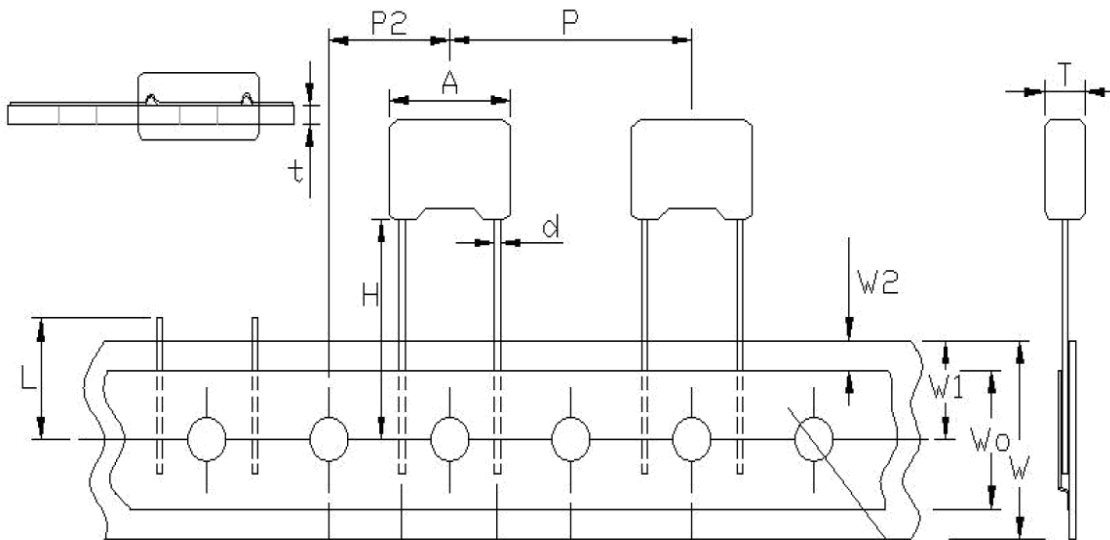

Descriptions	Symbol	Descriptions (mm)			Tolerances
		Lead spacing 10mm	Lead spacing 15mm	Lead spacing 22.5mm	
Carrier tape width	W	18	18	18	+1/-0.5
Hold-down tape width	W <sub>0</sub>	12 or 6	12 or 6	12 or 6	±0.5
Hotel position	W <sub>1</sub>	9	9	9	±0.5
Hole-down tape position	W <sub>2</sub>	3	3	3	Max
Feed hole diameter	D <sub>0</sub>	4	4	4	±0.2
Pitch of component	P	25.4	25.4	25.4	±1
Feed hole pitch	P <sub>0</sub> *	12.7	12.7	12.7	±0.2
Feed hole centre to lead	P <sub>1</sub>	7.7	5.2	7.8	±0.7
Feed hole centre to component centre	P <sub>2</sub>	12.7	12.7	19.05	±1.3
Height from feed hole centre to the component body	H	18.5	18.5	18.5	±0.5
Component alignment	△P	0	0	0	±1.3
	△S	0	0	0	±0.2
Lead spacing	p	10	15	22.5	+0.6/-0.1
Lead wire diameter	d	0.6	0.8	0.8	±0.5
Total tape thickness	t	0.7	0.7	0.7	±0.2
Component height	H <sub>1</sub>	31	34	39	Max

# CMPX Series

Metallized Polypropylene Film Capacitors  
Interference Suppressors Class – X2

**TRIGON**  
COMPONENTS

Packing: (mm)

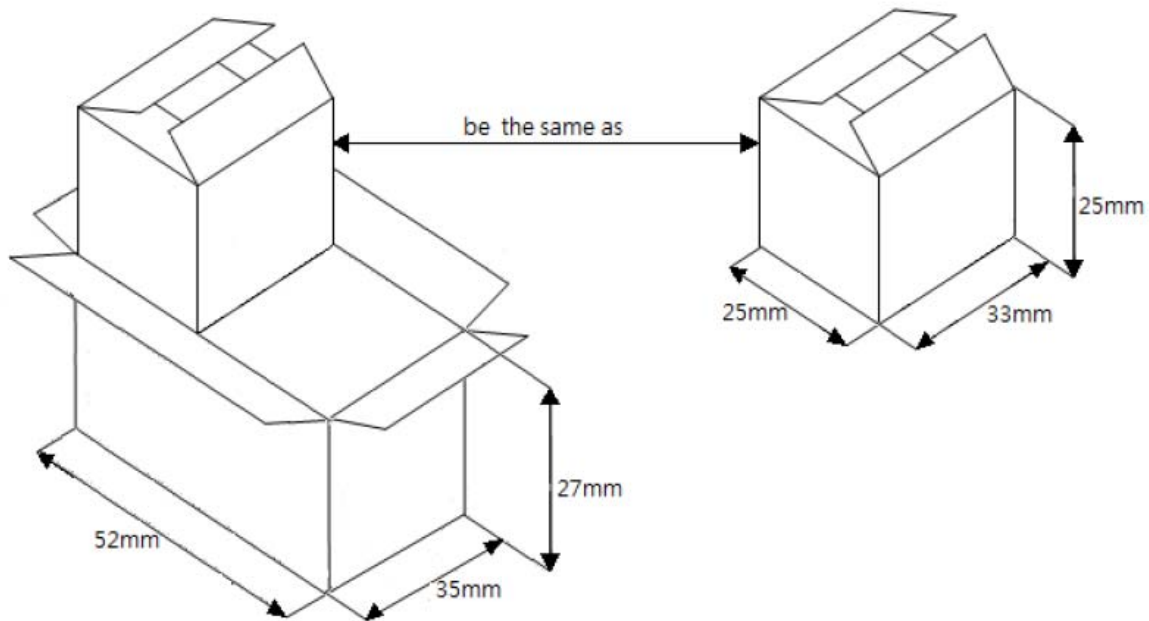

Capacitor

Description	Case Code	Pcs / Bag	Pcs / Big Box (L: 52mm X H: 27mm X T: 35mm)	Pcs / Small Box (L: 33mm X H: 25mm X T: 25mm)
CMPX104K27ALB	D1	500pcs	10000pcs	5000pcs

Case Dimension

Code	C1	C2	C3	C4
(W * T * H)	13 * 4 * 9	12 * 5 * 11	13 * 6 * 12	13 * 7 * 13
Code	C5LT	C8LT		
(W * T * H)	13 * 8 * 15	12 * 8 * 15		
Code	D1	D2	D3	D4
(W * T * H)	18 * 5 * 11	18 * 6 * 12	18 * 7.5 * 13.5	18 * 8.4 * 14.5
Code	E1	E2	E3	E4
(W * T * H)	26.5 * 6 * 15	26.5 * 7 * 16.5	26.5 * 8.5 * 17	26.5 * 10 * 19
Code	F1	F2	F3	F4
(W * T * H)	31.4 * 11 * 20	31.5 * 13 * 22	31 * 14 * 25	32 * 9 * 18