

ISS.	AMEND	DATE
1	ISSUED	12/02/16

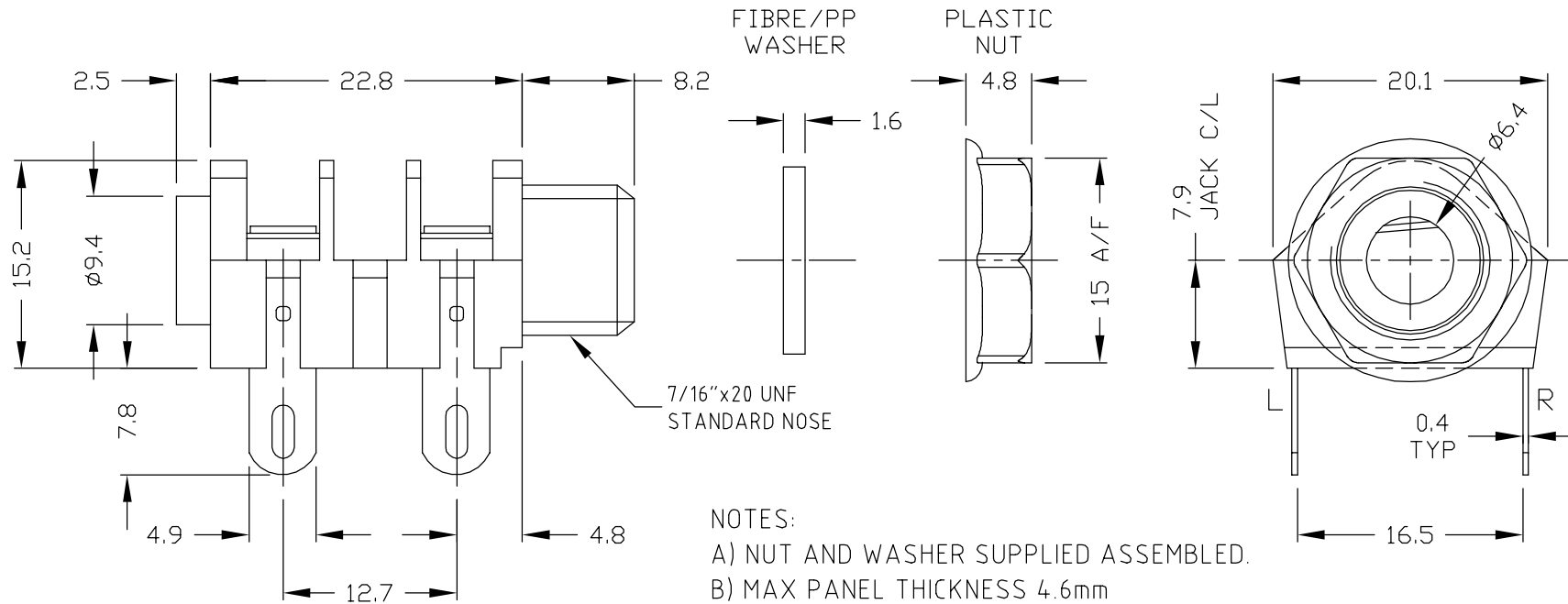

SPECIFICATION

Withstand voltage: 2000V DC Min.
 Maximum Current: 5A
 Temperature Rating: -10° C to +70° C
 Life (Minimum): 10,000+ Operations
 Nominal Contact Resistance: <50mΩ

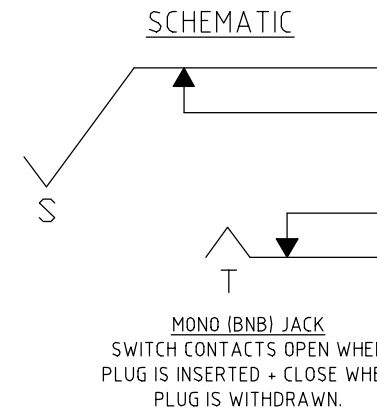

RoHS
COMPLIANT

TOLERANCE
 NO DEC. PLACE ±
 1 DEC. PLACE ±
 2 DEC. PLACE ±
 HOLE Ø ±
 ANGLES ±
 UNLESS OTHERWISE STATED

1st DRAWN: 11/01/1991

Cliff Electronic Components Ltd.
 76 Holmethorpe Avenue, Holmethorpe Industrial Estate,
 Redhill, Surrey, RH1 2PF, England, UK
 Tel: 01737-771375 Fax: 01737-766012 Website: www.cliffuk.co.uk

DIMENSIONS IN MILLIMETERS UNLESS OTHERWISE STATED. WORK TO DIMENSIONS. REMOVE ALL BURRS. IF IN DOUBT ASK.		3rd ANGLE PROJECTION:	DO NOT SCALE
MATERIAL: NYLON / NiAg / FIBRE / PP	TITLE: S2/BNB SOLDER TAG - ASSEMBLED		
FINISH: AS MOULDED - BLACK / MICROFINISH	DRAWG. No. CL1160A		FORM: A4DRWGH
DRAWN: T.J.O.	APPROVED: D.P.J.		