

CDBHM220-HF Thru. CDBHM260-HF

Reverse Voltage: 20 to 60 Volts

Forward Current: 2.0 Amp

RoHS Device

Halogen Free

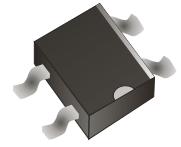

Features

- Schottky brier chip.
- Low power loss, high efficiency.
- Ideally suited for automatic assembly.
- Surge overload rating to 50A peak.
- Plastic case material has UL flammability classification rating 94V-0.

Mechanical data

- Case: MB-S, molded plastic.
- Terminals: Plated leads solderable per MIL-STD-202, Method 208.
- Polarity: As marked on case.
- Mounting position: Any.

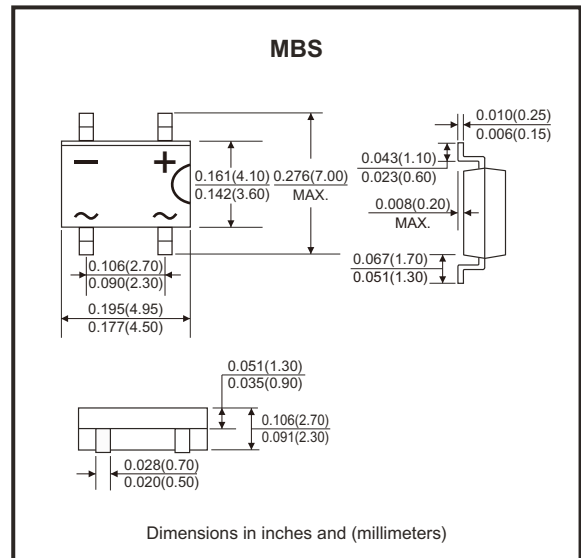

Circuit Diagram

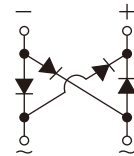

Maximum Ratings and Electrical Characteristics (at TA=25°C, unless otherwise specified)

Single phase, half wave, 60Hz, resistive or inductive load.
For capacitive load, derate current by 20%.

Parameter	Symbol	CDBHM						Unit	
		220-HF	230-HF	240-HF	245-HF	250-HF	260-HF		
Peak repetitive reverse voltage	V_{RRM}	20	30	40	45	50	60	V	
DC blocking voltage	V_{DC}	20	30	40	45	50	60	V	
RMS reverse voltage	$V_{R(RMS)}$	14	21	28	31	35	42	V	
Average rectified output current (Note 1) @Tc=100°C	$I_{F(AV)}$	2						A	
Non-Repetitive peak forward surge current, 8.3ms single half sine-wave superimposed on rated load (JEDEC method)	I_{FSM}	50						A	
I ² t rating for fusing (t< 8.3ms)	I^2t	10.375						A ² s	
Forward voltage per element	$I_F=2.0A$	V_{FM}	0.55			0.7		V	
Peak reverse current at rated DC blocking voltage	$T_J=25^\circ C$	I_{RM}	0.1						mA
	$T_J=100^\circ C$		10						
Typical junction capacitance per leg	C_j	28						pF	
Typical thermal resistance per leg (Note 2)	$R_{\theta JL}$	16						°C/W	
Operating junction temperature range	T_J	-55 to +150						°C	
Storage temperature range	T_{STG}	-55 to +150						°C	

Notes: 1. Mounted on aluminum substrate PC board with 1.3mm² solder pad.
2. Thermal resistance from junction to lead.

Company reserves the right to improve product design , functions and reliability without notice.

REV:A

Rating and Characteristics Curves (CDBHM220-HF Thru. CDBHM260-HF)

Fig.1 - Forward Current Derating Curve

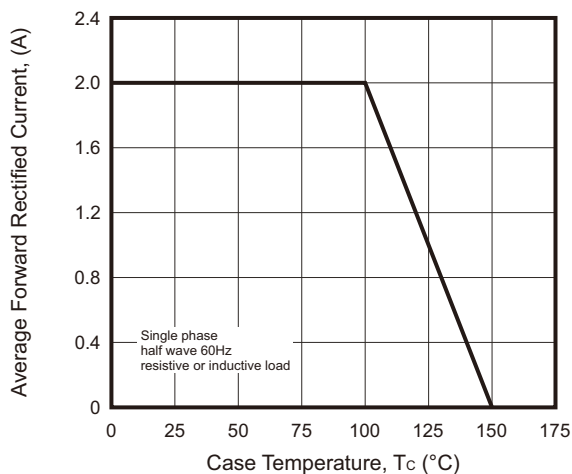

Fig.2 - Maximum Non-Repetitive Peak Forward Surge Current

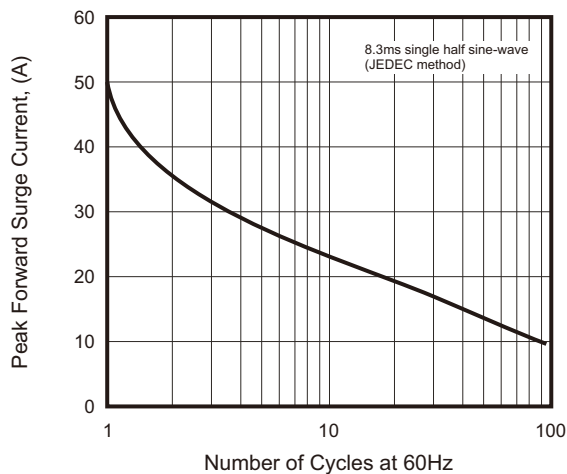

Fig.3 - Typical Instantaneous Forward Characteristics

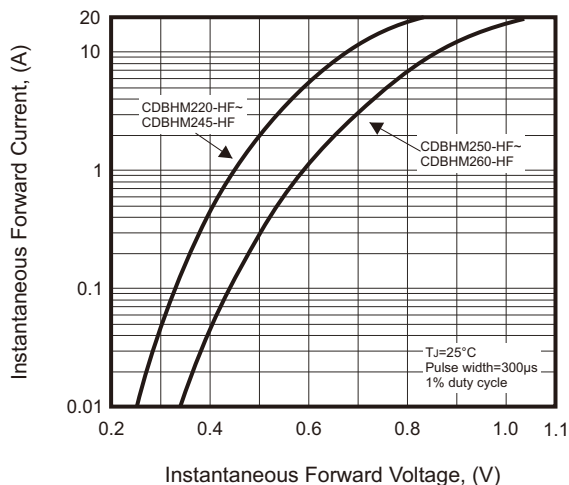
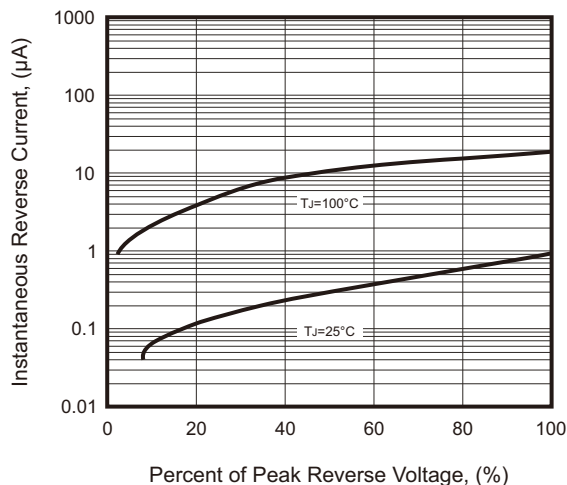
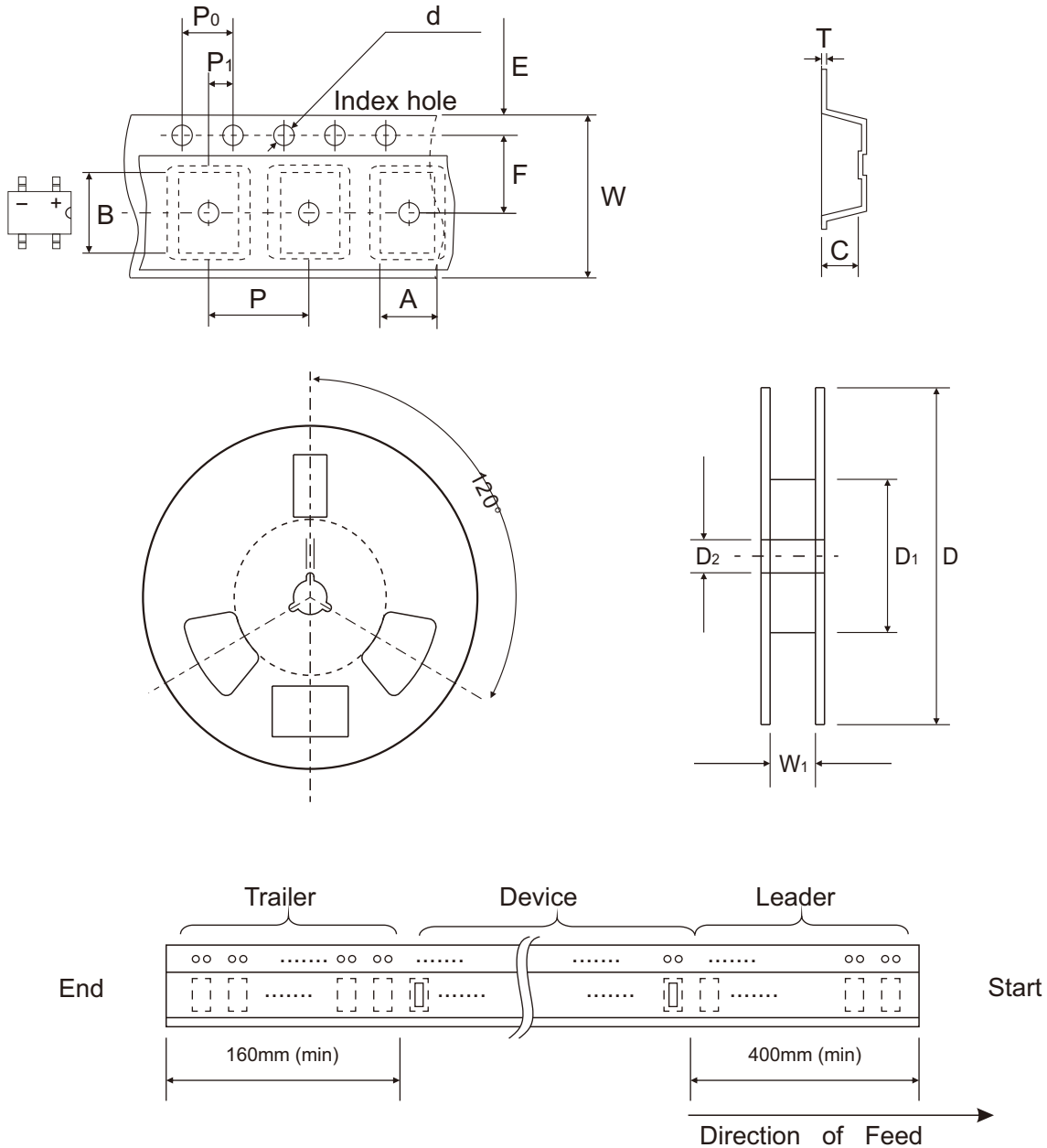

Fig.4 - Typical Reverse Characteristics



Reel Taping Specification



MBS	SYMBOL	A	B	C	d	D	D1	D2
	(mm)	5.02 ± 0.10	7.22 ± 0.10	2.88 ± 0.10	1.55 ± 0.05	330.00 ± 1.00	75.00 ± 1.00	13.50 + 1.00 - 0.50
	(inch)	0.198 ± 0.004	0.284 ± 0.004	0.113 ± 0.004	0.061 ± 0.002	12.992 ± 0.039	2.953 ± 0.039	0.531 + 0.039 - 0.020

MBS	SYMBOL	E	F	P	P0	P1	T	W	W1
	(mm)	1.75 ± 0.10	5.50 ± 0.05	8.00 ± 0.10	4.00 ± 0.10	2.00 ± 0.05	0.27 ± 0.03	12.00 ± 0.10	13.50 ± 1.00
	(inch)	0.069 ± 0.004	0.217 ± 0.002	0.315 ± 0.004	0.157 ± 0.004	0.079 ± 0.002	0.011 ± 0.001	0.472 ± 0.004	0.531 ± 0.039

Company reserves the right to improve product design , functions and reliability without notice.

REV:A

Marking Code

Part Number	Marking Code
CDBHM220-HF	KMB22SH
CDBHM230-HF	KMB23SH
CDBHM240-HF	KMB24SH
CDBHM245-HF	KMB245SH
CDBHM250-HF	KMB25SH
CDBHM260-HF	KMB26SH

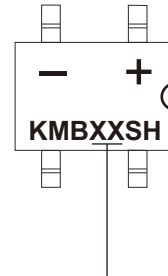

XX/XXX = Product type marking code

Suggested PAD Layout

SIZE	MBS	
	(mm)	(inch)
A	0.90	0.035
B	1.84	0.072
C	2.40	0.094
D	6.00	0.236

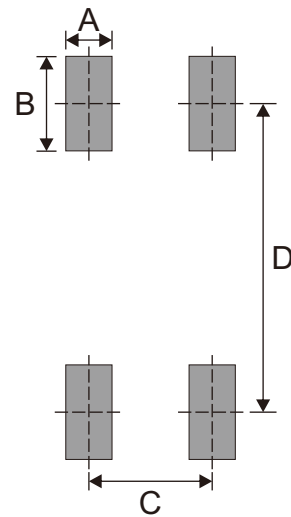

Standard Packaging

Case Type	REEL PACK	
	REEL (pcs)	Reel Size (inch)
MBS	3,000	13