



# Model CC Series

## Advanced PLL LVPECL or LVDS Clock

### Features

- Ceramic Surface Mount Package
- Very Low Phase Jitter Performance, 150fs Typical
- Quartz Crystal Based Design
- Frequency Range to 2.1GHz \*
- +1.8V, +2.5V or +3.3V Operation
- Output Enable Standard
- Tape and Reel Packaging, EIA-481

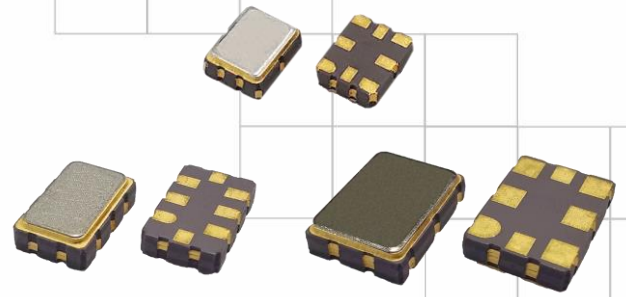

Part Dimensions:  
 3.2 × 2.5 × 1.2mm • 26.64mg  
 5.0 × 3.2 × 1.5mm • 61.8mg  
 7.0 × 5.0 × 1.9mm • 172.74mg

### Applications

- SerDes
- Storage Area Networking
- Broadband Access
- SONET/SDH/DWDM
- PON
- Ethernet/Gbe/SyncE
- Fiber Channel
- Medical Electronics
- Test and Measurement

### Description

CTS Model CC Series is a high-performance clock oscillator supporting differential LVPECL or LVDS outputs. Employing the latest IC technology, CC Series has excellent stability and low jitter/phase noise performance.

### Ordering Information

Model	Package Size	Output Type	Frequency Stability	Temperature Range	Supply Voltage	Frequency Code (MHz)	Packaging																												
CC	3	P	3	I	L	1244M16000	R																												
	<table border="1"> <thead> <tr> <th>Code</th> <th>Dimensions</th> </tr> </thead> <tbody> <tr> <td>3</td> <td>3.2mmx2.5mm</td> </tr> <tr> <td>5</td> <td>5.0mmx3.2mm</td> </tr> <tr> <td>7</td> <td>7.0mmx5.0mm</td> </tr> </tbody> </table>	Code	Dimensions	3	3.2mmx2.5mm	5	5.0mmx3.2mm	7	7.0mmx5.0mm		<table border="1"> <thead> <tr> <th>Code</th> <th>Stability</th> </tr> </thead> <tbody> <tr> <td>5</td> <td>±25ppm</td> </tr> <tr> <td>3</td> <td>±50ppm</td> </tr> </tbody> </table>	Code	Stability	5	±25ppm	3	±50ppm		<table border="1"> <thead> <tr> <th>Code</th> <th>Voltage</th> </tr> </thead> <tbody> <tr> <td>M</td> <td>+1.8Vdc<sup>2</sup></td> </tr> <tr> <td>N</td> <td>+2.5Vdc</td> </tr> <tr> <td>L</td> <td>+3.3Vdc</td> </tr> </tbody> </table>	Code	Voltage	M	+1.8Vdc <sup>2</sup>	N	+2.5Vdc	L	+3.3Vdc		<table border="1"> <thead> <tr> <th>Code</th> <th>Packing<sup>3</sup></th> </tr> </thead> <tbody> <tr> <td>T</td> <td>1k pcs./reel</td> </tr> <tr> <td>R</td> <td>3k pcs./reel</td> </tr> </tbody> </table>	Code	Packing <sup>3</sup>	T	1k pcs./reel	R	3k pcs./reel
Code	Dimensions																																		
3	3.2mmx2.5mm																																		
5	5.0mmx3.2mm																																		
7	7.0mmx5.0mm																																		
Code	Stability																																		
5	±25ppm																																		
3	±50ppm																																		
Code	Voltage																																		
M	+1.8Vdc <sup>2</sup>																																		
N	+2.5Vdc																																		
L	+3.3Vdc																																		
Code	Packing <sup>3</sup>																																		
T	1k pcs./reel																																		
R	3k pcs./reel																																		
		<table border="1"> <thead> <tr> <th>Code</th> <th>Output</th> </tr> </thead> <tbody> <tr> <td>P</td> <td>LVPECL</td> </tr> <tr> <td>L</td> <td>LVDS</td> </tr> </tbody> </table>	Code	Output	P	LVPECL	L	LVDS		<table border="1"> <thead> <tr> <th>Code</th> <th>Temp. Range</th> </tr> </thead> <tbody> <tr> <td>C</td> <td>-20°C to +70°C</td> </tr> <tr> <td>I</td> <td>-40°C to +85°C</td> </tr> </tbody> </table>	Code	Temp. Range	C	-20°C to +70°C	I	-40°C to +85°C		<table border="1"> <thead> <tr> <th>Code</th> <th>Frequency (MHz)<sup>1</sup></th> </tr> </thead> <tbody> <tr> <td></td> <td>1244M16000</td> </tr> </tbody> </table>	Code	Frequency (MHz) <sup>1</sup>		1244M16000													
Code	Output																																		
P	LVPECL																																		
L	LVDS																																		
Code	Temp. Range																																		
C	-20°C to +70°C																																		
I	-40°C to +85°C																																		
Code	Frequency (MHz) <sup>1</sup>																																		
	1244M16000																																		

Notes:

- 1) Frequency is recorded with 4 leading significant digits [including zeros] before and 5 significant digits [including zeroes] after the "M".  
 [Ex. 1244.160000MHz = 1244M16000, 156.250000MHz = 0156M25000, 608.750000MHz = 0608M75000]
- 2) LVDS output only.
- 3) Code T for package codes 50 and 70. Code T or R for package code 32 only.

**Not all performance combinations and frequencies may be available.  
 Contact your local CTS Representative or CTS Customer Service for availability.**

This product is specified for use only in standard commercial applications. Supplier disclaims all express and implied warranties and liability in connection with any use of this product in any non-commercial applications or in any application that may expose the product to conditions that are outside of the tolerances provided in its specification.



## Electrical Specifications

### Operating Conditions

PARAMETER	SYMBOL	CONDITIONS	MIN	TYP	MAX	UNIT
Maximum Supply Voltage	$V_{CC}$	-	-0.5	-	3.8	V
Supply Voltage	$V_{CC}$	$\pm 5\%$ , LVDS only	1.71	1.8	1.89	V
		$\pm 10\%$	2.25	2.5	2.75	
			2.97	3.3	3.63	
<b>Supply Current</b>						
LVPECL	$I_{CC}$	Maximum Load	-	100	120	mA
LVDS		Maximum Current Value @ +3.3V	-	75	90	
Operating Temperature	$T_A$	-	-20	+25	+70	°C
			-40		+85	
Storage Temperature	$T_{STG}$	-	-55	-	+125	°C

### Frequency Stability

PARAMETER	SYMBOL	CONDITIONS	MIN	TYP	MAX	UNIT
Frequency Range	$f_O$	-		100 - 2,100		MHz
Frequency Stability [Note 1]	$\Delta f/f_O$	-		25 or 50		$\pm$ ppm
Aging	$\Delta f/f_{25}$	First Year @ +25°C, nominal $V_{CC}$	-3	-	3	ppm

1.] Inclusive of initial tolerance at time of shipment, changes in supply voltage, load, temperature and 1st year aging.

### Output Parameters

PARAMETER	SYMBOL	CONDITIONS	MIN	TYP	MAX	UNIT
Output Type	-	-		<b>LVPECL</b>		-
Output Load	$R_L$	Terminated to $V_{CC} - 2.0V$	-	50	-	Ohms
Output Voltage Levels	$V_{OH}$	PECL Load	$V_{CC} - 1.165$	-	$V_{CC} - 0.80$	V
	$V_{OL}$		$V_{CC} - 2.0$	-	$V_{CC} - 1.55$	
Output Duty Cycle	SYM	@ $V_{CC} - 1.3V$	45	-	55	%
Differential Output Voltage	$V_{OD}$	$R_L = 50$ Ohms	595	-	930	mV
Rise and Fall Time	$T_{R, T_F}$	@ 20%/80% Levels, $R_L = 50$ Ohms	-	-	0.40	ns
<b>LVDS</b>						
Output Type	-	-		<b>LVDS</b>		-
Output Load	$R_L$	Between Outputs	-	100	-	Ohms
Output Voltage Levels	$V_{OH}$	LVDS Load	-	1.40	1.60	V
	$V_{OL}$		0.90	1.10	-	
Output Duty Cycle	SYM	@ 1.25V	45	-	55	%
Differential Output Voltage	$V_{OD}$	$R_L = 100$ Ohms	250	-	450	mV
Offset Voltage	$V_{OS}$	LVDS Load	1.20	1.25	1.30	V
Rise and Fall Time	$T_{R, T_F}$	@ 20%/80% Levels, $R_L = 100$ Ohms	-	-	0.40	ns

## Electrical Specifications

### Output Parameters

PARAMETER	SYMBOL	CONDITIONS	MIN	TYP	MAX	UNIT
Start Up Time	$T_S$	Application of $V_{CC}$	-	5	10	ms
<b>Enable Function [Tri-State]</b>						
Enable Input Voltage	$V_{IH}$	Pin 2 Logic '1', Output Enabled	$0.8V_{CC}$	-	-	V
Disable Input Voltage	$V_{IL}$	Pin 2 Logic '0', Output Disabled	-	-	$0.2V_{CC}$	V
Disable Current	$I_{IL}$	Pin 2 Logic '0', Output Disabled, LVPECL	-	99	-	mA
		Pin 2 Logic '0', Output Disabled, LVDS	-	74	-	
Disable Time	$T_{PLZ}$	Pin 2 Logic '0', Output Disabled	-	-	10	$\mu$ s
Enable Time	$T_{PLZ}$	Pin 2 Logic '1', Output Enabled	-	-	2.5	ms
Phase Jitter, RMS	$t_{jrms}$	Bandwidth 12 kHz - 20 MHz	-	150	300	fs

### Enable Truth Table

LVPECL or LVDS

Pin 1	Pin 4 & Pin 5
Logic '1'	Output Enabled
Open	Output Enabled
Logic '0'	Output Disabled, High Impedance

### Output Waveform

LVPECL or LVDS

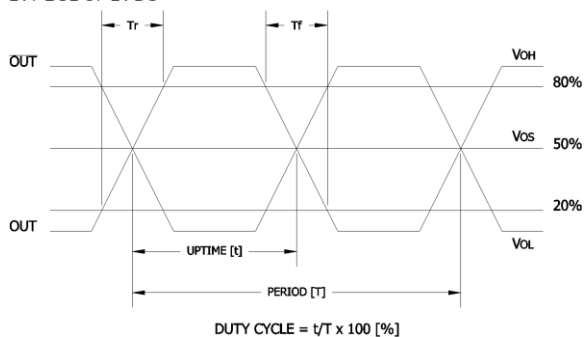

## Electrical Specifications

Test Circuit  
LVPECL

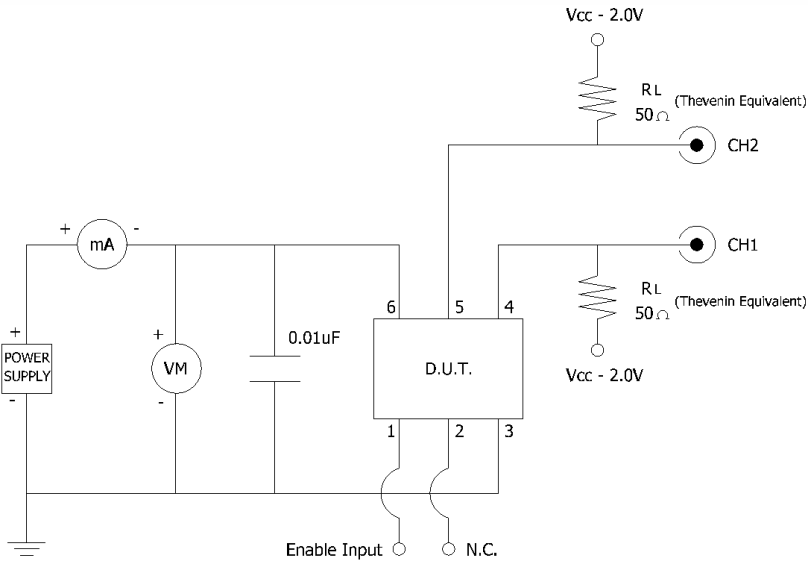

LVDS

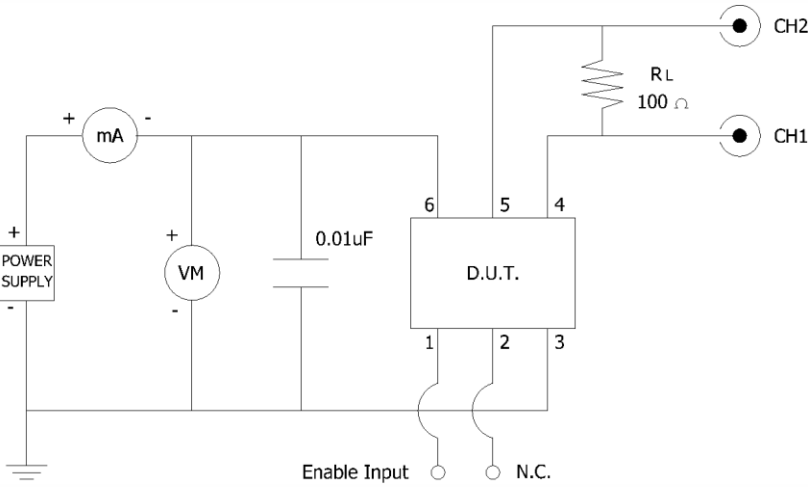

LVDS @ +1.8V

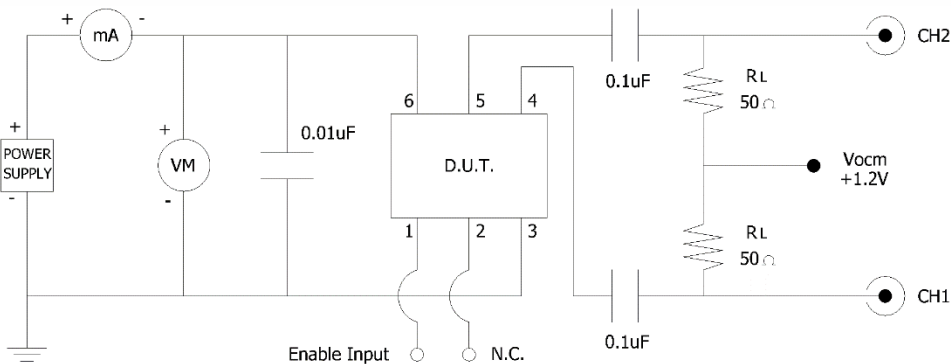



### Electrical Specifications

#### Performance Data

##### Phase Noise [typical]

100MHz, V<sub>CC</sub> = +3.3V, T<sub>A</sub> = +25°C

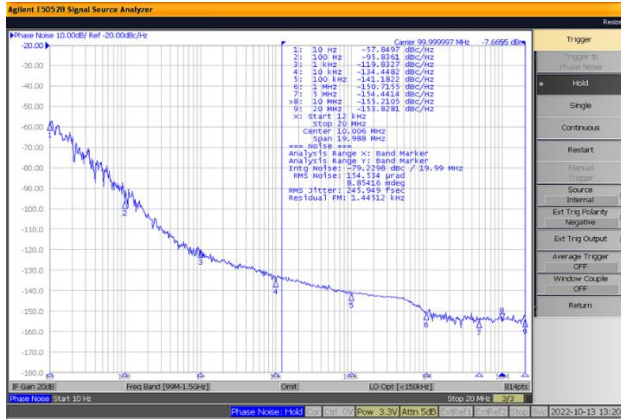

106.25MHz, V<sub>CC</sub> = +3.3V, T<sub>A</sub> = +25°C

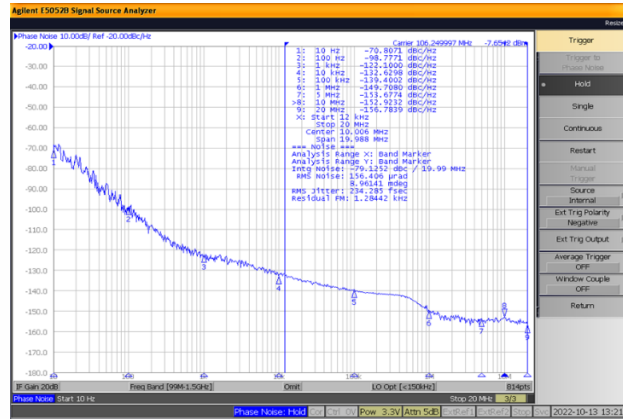

122.88MHz, V<sub>CC</sub> = +3.3V, T<sub>A</sub> = +25°C

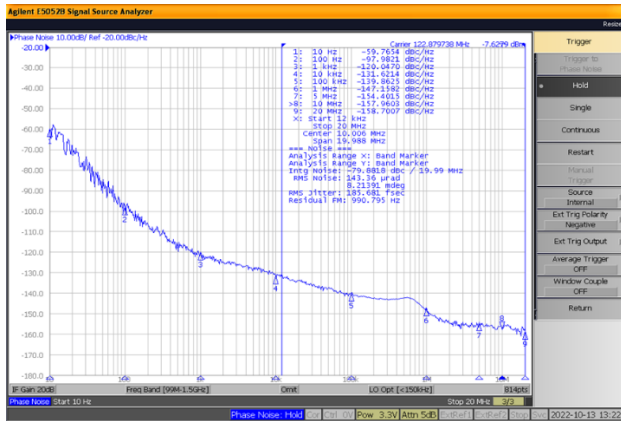

125MHz, V<sub>CC</sub> = +3.3V, T<sub>A</sub> = +25°C

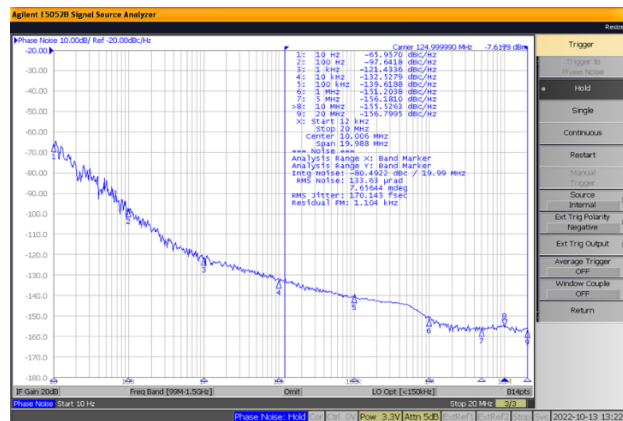

150MHz, V<sub>CC</sub> = +3.3V, T<sub>A</sub> = +25°C

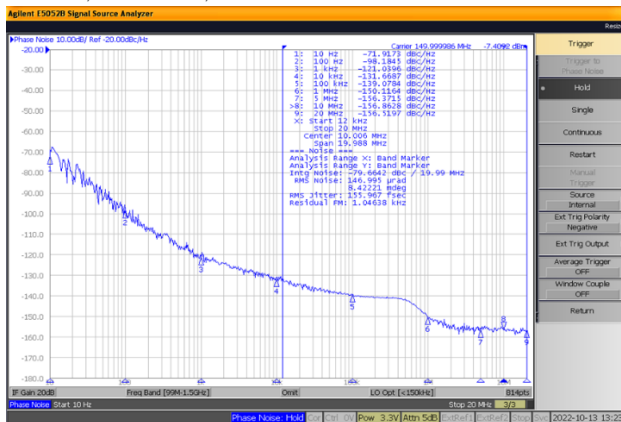

156.25MHz, V<sub>CC</sub> = +3.3V, T<sub>A</sub> = +25°C

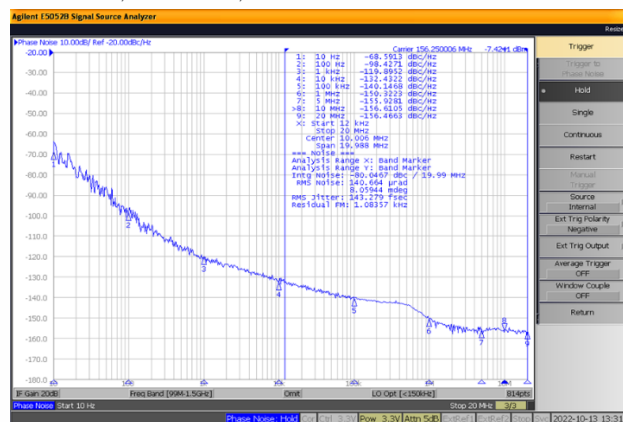



### Electrical Specifications

#### Performance Data

##### Phase Noise [typical]

200MHz,  $V_{CC} = +3.3V$ ,  $T_A = +25^\circ C$

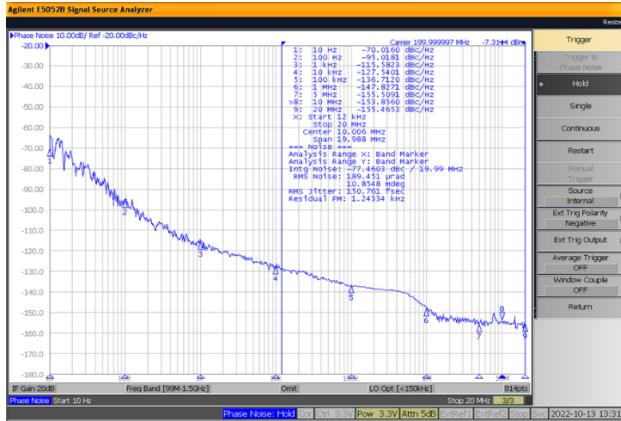

212.5MHz,  $V_{CC} = +3.3V$ ,  $T_A = +25^\circ C$

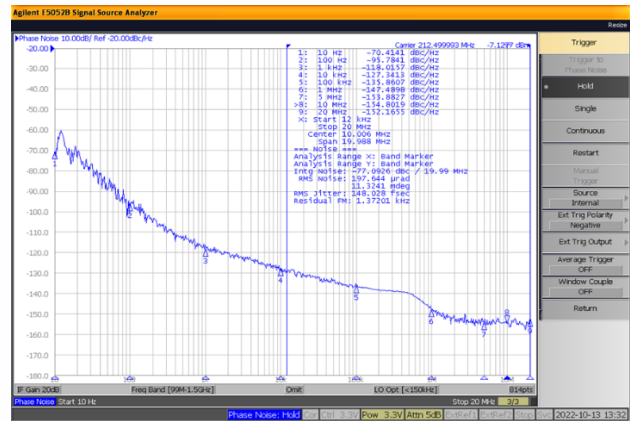

250MHz,  $V_{CC} = +3.3V$ ,  $T_A = +25^\circ C$

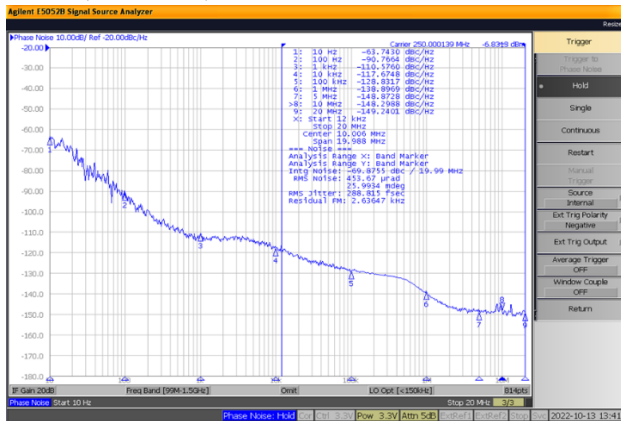

312.5MHz,  $V_{CC} = +3.3V$ ,  $T_A = +25^\circ C$

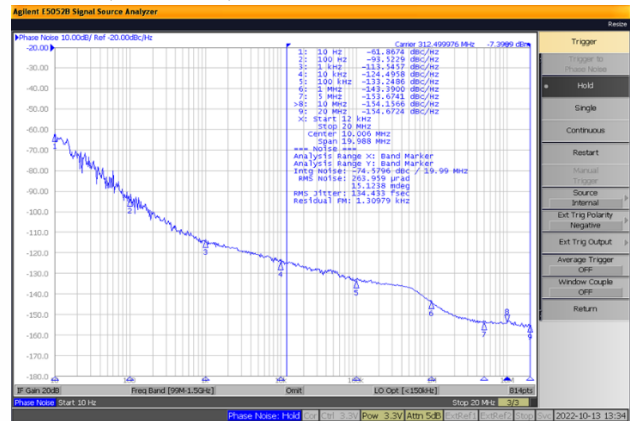

622.08MHz,  $V_{CC} = +3.3V$ ,  $T_A = +25^\circ C$

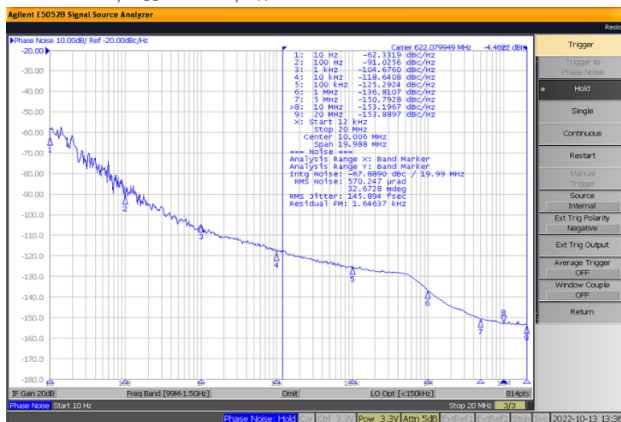

644.53125MHz,  $V_{CC} = +3.3V$ ,  $T_A = +25^\circ C$

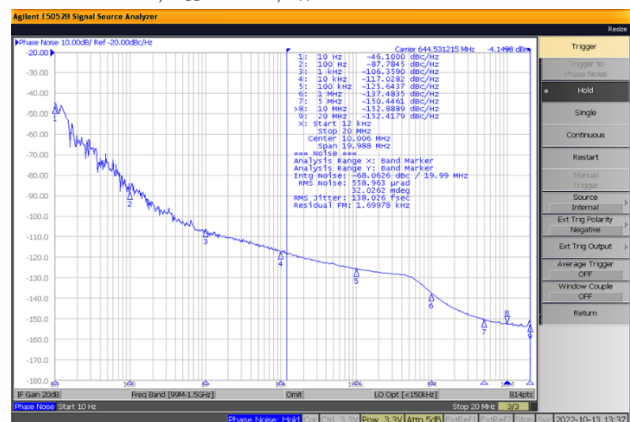



## Electrical Specifications

### Performance Data

#### Phase Noise Tabulated

Typical,  $V_{CC} = +3.3V$ ,  $T_A = +25^\circ C$

PARAMETER	SYMBOL	CONDITIONS	TYP	UNIT
<b>100.0000MHz</b>				
Phase Noise		Single Side Band		
		@ 10Hz	-57.8497	
		@ 100Hz	-95.8361	
		@ 1kHz	-119.8327	
		@ 10kHz	-134.4482	dBc/Hz
		@ 100kHz	-141.1822	
		@ 1MHz	-150.7155	
		@ 5MHz	-154.4414	
		@ 10MHz	-155.2105	
	@ 20MHz	-153.8281		
Phase Jitter, RMS	tjrms	Integration Bandwidth 12kHz - 20MHz	245.9490	

PARAMETER	SYMBOL	CONDITIONS	TYP	UNIT
<b>122.8800MHz</b>				
Phase Noise		Single Side Band		
		@ 10Hz	-59.7654	
		@ 100Hz	-97.9821	
		@ 1kHz	-120.0470	
		@ 10kHz	-131.6214	dBc/Hz
		@ 100kHz	-139.8625	
		@ 1MHz	-147.1582	
		@ 5MHz	-154.4015	
		@ 10MHz	-157.9603	
	@ 20MHz	-158.7007		
Phase Jitter, RMS	tjrms	Integration Bandwidth 12kHz - 20MHz	185.6810	

PARAMETER	SYMBOL	CONDITIONS	TYP	UNIT
<b>150.0000MHz</b>				
Phase Noise		Single Side Band		
		@ 10Hz	-71.9173	
		@ 100Hz	-98.1845	
		@ 1kHz	-121.0396	
		@ 10kHz	-131.6687	dBc/Hz
		@ 100kHz	-139.0784	
		@ 1MHz	-150.1164	
		@ 5MHz	-156.3715	
		@ 10MHz	-156.8628	
	@ 20MHz	-156.5197		
Phase Jitter, RMS	tjrms	Integration Bandwidth 12kHz - 20MHz	155.9670	

Typical,  $V_{CC} = +3.3V$ ,  $T_A = +25^\circ C$

PARAMETER	SYMBOL	CONDITIONS	TYP	UNIT
<b>106.250MHz</b>				
Phase Noise		Single Side Band		
		@ 10Hz	-70.8071	
		@ 100Hz	-98.7771	
		@ 1kHz	-122.1000	
		@ 10kHz	-132.6298	dBc/Hz
		@ 100kHz	-139.4002	
		@ 1MHz	-149.7080	
		@ 5MHz	-153.6774	
		@ 10MHz	-152.9232	
	@ 20MHz	-156.7839		
Phase Jitter, RMS	tjrms	Integration Bandwidth 12kHz - 20MHz	234.2850	

PARAMETER	SYMBOL	CONDITIONS	TYP	UNIT
<b>125.0000MHz</b>				
Phase Noise		Single Side Band		
		@ 10Hz	-65.9570	
		@ 100Hz	-97.6418	
		@ 1kHz	-121.4336	
		@ 10kHz	-132.5279	dBc/Hz
		@ 100kHz	-139.6188	
		@ 1MHz	-151.2038	
		@ 5MHz	-156.1810	
		@ 10MHz	-155.5263	
	@ 20MHz	-156.7995		
Phase Jitter, RMS	tjrms	Integration Bandwidth 12kHz - 20MHz	170.1430	

PARAMETER	SYMBOL	CONDITIONS	TYP	UNIT
<b>156.2500MHz</b>				
Phase Noise		Single Side Band		
		@ 10Hz	-68.5913	
		@ 100Hz	-98.4271	
		@ 1kHz	-119.8952	
		@ 10kHz	-132.4322	dBc/Hz
		@ 100kHz	-140.1468	
		@ 1MHz	-150.3223	
		@ 5MHz	-155.9281	
		@ 10MHz	-156.6105	
	@ 20MHz	-156.4663		
Phase Jitter, RMS	tjrms	Integration Bandwidth 12kHz - 20MHz	143.2790	



## Electrical Specifications

### Performance Data

#### Phase Noise Tabulated

Typical,  $V_{CC} = +3.3V$ ,  $T_A = +25^\circ C$

PARAMETER	SYMBOL	CONDITIONS	TYP	UNIT	
<b>200.0000MHz</b>					
Phase Noise		Single Side Band			
		@ 10Hz	-70.0160		
		@ 100Hz	-95.0181		
		@ 1kHz	-115.5823		
		@ 10kHz	-127.5401	dBc/Hz	
		@ 100kHz	-136.7120		
		@ 1MHz	-147.8271		
		@ 5MHz	-155.5091		
		@ 10MHz	-153.8560		
	@ 20MHz	-155.4653			
Phase Jitter, RMS	tjrms	Integration Bandwidth 12kHz - 20MHz	150.7610		fs

PARAMETER	SYMBOL	CONDITIONS	TYP	UNIT	
<b>250.0000MHz</b>					
Phase Noise		Single Side Band			
		@ 10Hz	-63.7430		
		@ 100Hz	-90.7664		
		@ 1kHz	-110.5760		
		@ 10kHz	-117.6748	dBc/Hz	
		@ 100kHz	-128.8317		
		@ 1MHz	-138.8969		
		@ 5MHz	-148.8728		
		@ 10MHz	-148.2933		
	@ 20MHz	-149.2401			
Phase Jitter, RMS	tjrms	Integration Bandwidth 12kHz - 20MHz	288.8150		fs

PARAMETER	SYMBOL	CONDITIONS	TYP	UNIT	
<b>622.0800MHz</b>					
Phase Noise		Single Side Band			
		@ 10Hz	-62.3319		
		@ 100Hz	-91.0256		
		@ 1kHz	-104.6760		
		@ 10kHz	-118.6408	dBc/Hz	
		@ 100kHz	-125.2924		
		@ 1MHz	-136.8107		
		@ 5MHz	-150.7928		
		@ 10MHz	-153.1967		
	@ 20MHz	-153.8897			
Phase Jitter, RMS	tjrms	Integration Bandwidth 12kHz - 20MHz	145.8940		fs

Typical,  $V_{CC} = +3.3V$ ,  $T_A = +25^\circ C$

PARAMETER	SYMBOL	CONDITIONS	TYP	UNIT	
<b>212.5000MHz</b>					
Phase Noise		Single Side Band			
		@ 10Hz	-70.4141		
		@ 100Hz	-95.7841		
		@ 1kHz	-118.0157		
		@ 10kHz	-127.3413	dBc/Hz	
		@ 100kHz	-135.8607		
		@ 1MHz	-147.4898		
		@ 5MHz	-153.8827		
		@ 10MHz	-154.8019		
	@ 20MHz	-152.1655			
Phase Jitter, RMS	tjrms	Integration Bandwidth 12kHz - 20MHz	148.0280		fs

PARAMETER	SYMBOL	CONDITIONS	TYP	UNIT	
<b>312.5000MHz</b>					
Phase Noise		Single Side Band			
		@ 10Hz	-61.8674		
		@ 100Hz	-93.5229		
		@ 1kHz	-113.5457		
		@ 10kHz	-124.4958	dBc/Hz	
		@ 100kHz	-133.2486		
		@ 1MHz	-143.3900		
		@ 5MHz	-153.6741		
		@ 10MHz	-154.1566		
	@ 20MHz	-154.6724			
Phase Jitter, RMS	tjrms	Integration Bandwidth 12kHz - 20MHz	134.4330		fs

PARAMETER	SYMBOL	CONDITIONS	TYP	UNIT	
<b>644.53125MHz</b>					
Phase Noise		Single Side Band			
		@ 10Hz	-46.1000		
		@ 100Hz	-87.7845		
		@ 1kHz	-106.3590		
		@ 10kHz	-117.0282	dBc/Hz	
		@ 100kHz	-125.6437		
		@ 1MHz	-137.4835		
		@ 5MHz	-150.4461		
		@ 10MHz	-152.8889		
	@ 20MHz	-152.4179			
Phase Jitter, RMS	tjrms	Integration Bandwidth 12kHz - 20MHz	138.0260		fs



## Mechanical Specifications

### Package Drawing

#### CC32

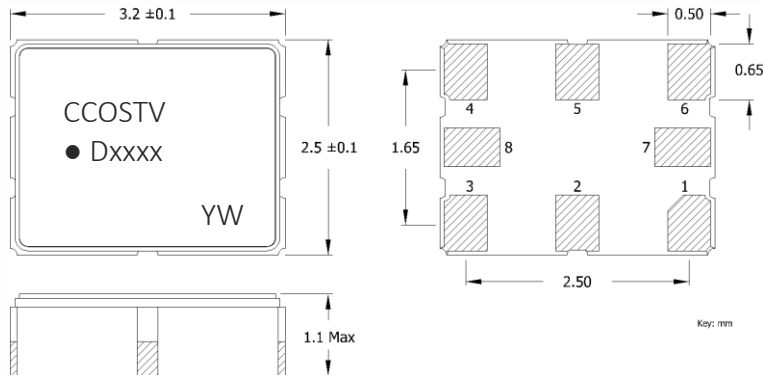

#### CC50

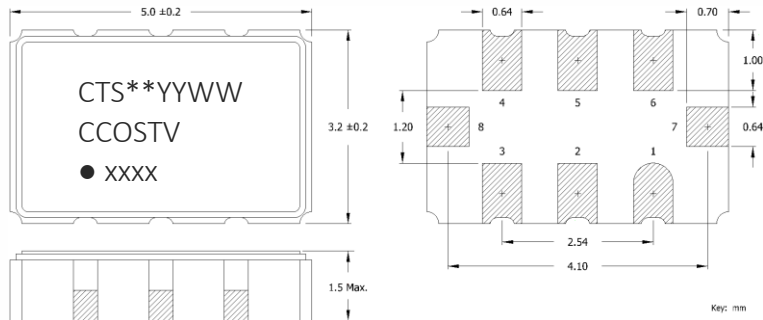

#### CC70

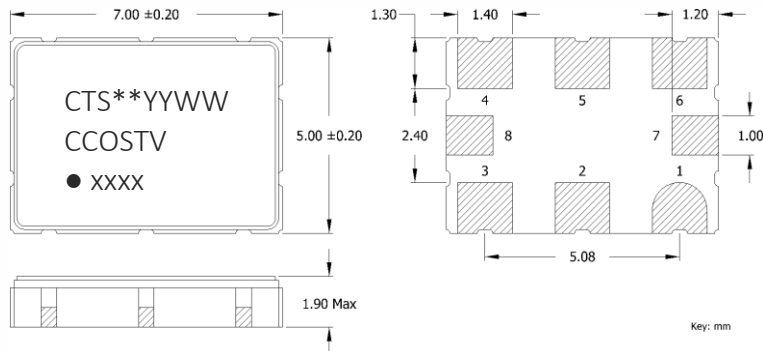

### Marking Information

#### CC32

1. CC – Model series.
2. O – Output Type; P = LVPECL, L = LVDS.
3. ST – Frequency Stability/Temperature Code. [Refer to Ordering Information]
4. V – Voltage Code; M = 1.8V, N = 2.5V, L = 3.3V.
5. D – Date Code. See Table I for codes.
6. xxxx – Frequency Code.  
3-digits, frequencies below 100MHz  
4-digits, frequencies 100MHz or greater  
[See document 016-1454-0, Frequency Code Tables.]
7. YW [Optional] – CTS Internal Marking for Traceability.

#### CC50 and CC70

1. \*\* - Manufacturing Site Code.
2. YYWW – Date Code; YY – year, WW – week.
3. CC – Model series.
4. O – Output Type; P = LVPECL, L = LVDS.
5. ST – Frequency Stability/Temperature Code. [Refer to Ordering Information]
6. V – Voltage Code; M = 1.8V, N = 2.5V, L = 3.3V.
7. xxxx – Frequency Code.  
3-digits, frequencies below 100MHz  
4-digits, frequencies 100MHz or greater  
[See document 016-1454-0, Frequency Code Tables.]

### Notes

1. JEDEC termination code (e4). Barrier-plating is nickel [Ni] with gold [Au] flash plate.
2. Reflow conditions per JEDEC J-STD-020; +260°C maximum, 20 seconds.
3. MSL = 1.

## Mechanical Specifications

### Recommended Pad Layout

CC32

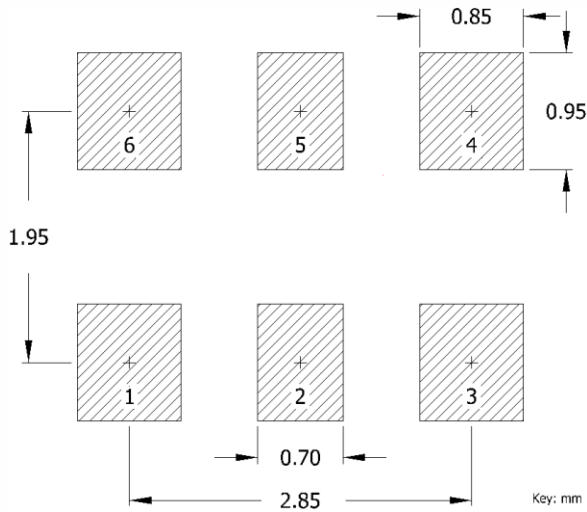

CC50

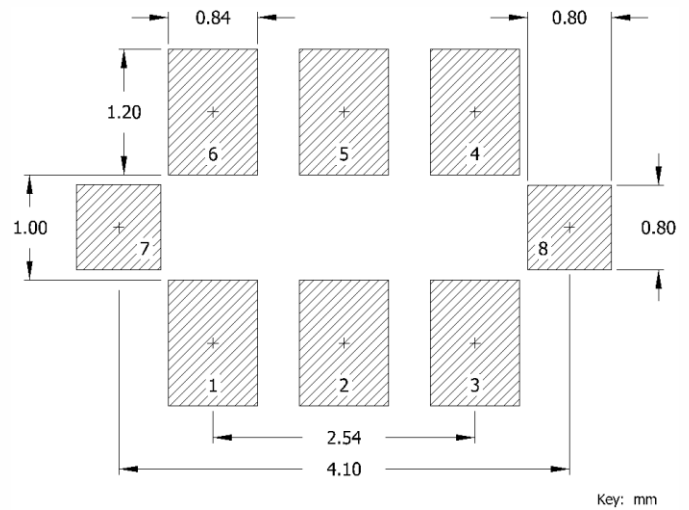

CC70

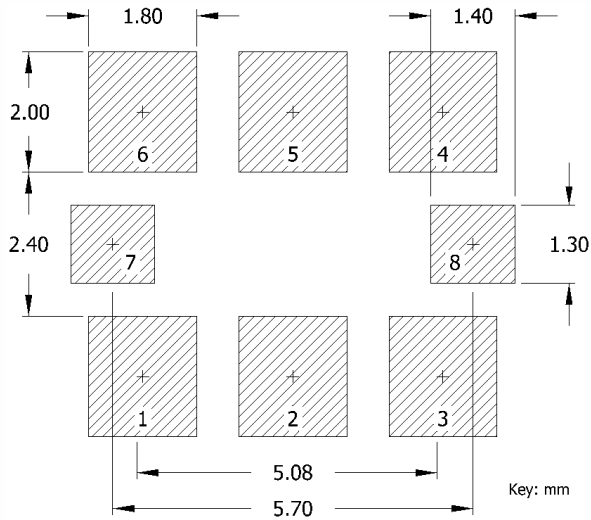

### Pin Assignments

LVPECL or LVDS

Pin	Symbol	Function
1	EOH	Enable
2	N.C.	No Connect
3	GND	Circuit & Package Ground
4	Output	RF Output
5	Output	Complimentary RF Output
6	V <sub>CC</sub>	Supply Voltage
7	N.C.	Do Not Connect
8	N.C.	Do Not Connect

### VOLTAGE SUPPLY - BYPASS CAPACITOR

Proper filtering of high frequency noise riding on the voltage supply line is critical to eliminating the injecting of that noise into the oscillator and throughout the system. It is recommended that a 0.1 $\mu$ F [100nF] capacitor be inserted from the V<sub>CC</sub> pin to circuit ground. The bypass capacitor placement should be as close to the V<sub>CC</sub> pad as possible with a short trace routing to circuit ground.

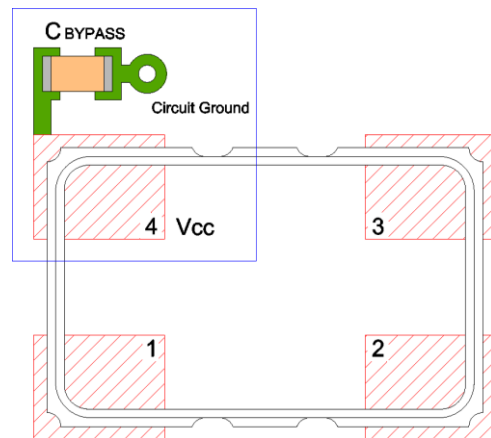

## Mechanical Specifications

Table I - Date Code, Beginning year 2021

MONTH					JAN	FEB	MAR	APR	MAY	JUN	JUL	AUG	SEP	OCT	NOV	DEC
YEAR																
2021	2025	2029	2033	2037	A	B	C	D	E	F	G	H	J	K	L	M
2022	2026	2030	2034	2038	N	P	Q	R	S	T	U	V	W	X	Y	Z
2023	2027	2031	2035	2039	a	b	c	d	e	f	g	h	j	k	l	m
2024	2028	2032	2036	2040	n	p	q	r	s	t	u	v	w	x	y	z

## Packaging - Tape and Reel

### Tape Drawing

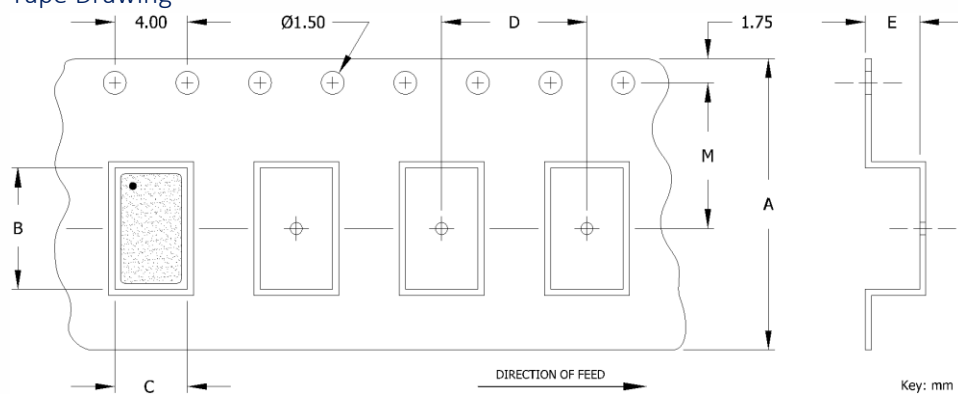

### Reel Drawing

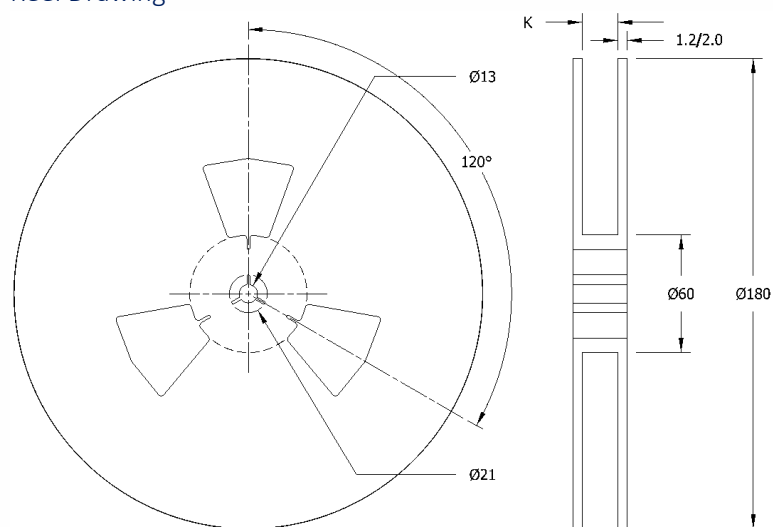

### Tape Dimensions

PACKAGE	A	B	C	D	E	M	QUANTITY
CC32	8.00	3.40	2.70	4.00	1.40	3.50	3000
CC50	12.00	5.30	3.60	8.00	1.40	5.50	1000
CC70	16.00	7.30	5.30	8.00	1.90	7.50	1000

### Reel Dimensions

K
8.00
13.00
17.20

### Notes

- Complete CTS part number, frequency value and date code information must appear on reel and carton labels.