





Drawing No.	*Rev.	Date	Page
CBL3528D-ZRN-020mA	A	2023/02/14	1/10

APPROVAL SHEET

Part No: **CBL3528D-ZRN-020mA**

NOTE : **Green Part**

MAKER			CUSTOMER	
				
R&D	QA	Sales	Checked	Approved
				

Prepared	Checked	Approved
Rachel Lee	Sky Lin	Kenneth Wu

Package outlines

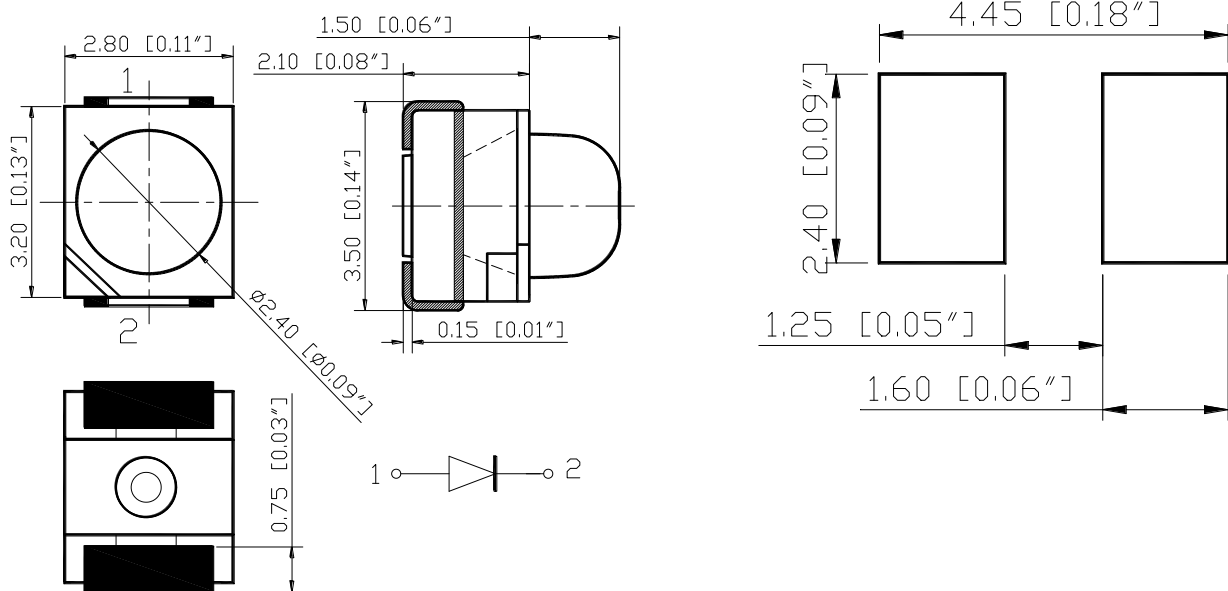



ATTENTION
OBSERVE PRECAUTIONS
FOR HANDLING
ELECTROSTATIC
SENSITIVE DEVICES

ITEM	MATERIALS
Resin	Epoxy
Lens color	Water transparent
Dice	AlGaInP
Emitted color	Orange

NOTES:

- All dimensions are in millimeters (inches);
- Tolerances are $\pm 0.2\text{mm}$ (0.008inch) unless otherwise noted.

Absolute maximum ratings

($T_A=25^{\circ}\text{C}$)

Parameter	Symbol	Value	Unit
Forward current	I _f	30	mA
Reverse voltage	V _r	5	V
Power dissipation	P _d	75	mW
Operating temperature range	T _{op}	-40 ~+80	°C
Storage temperature range	T _{stg}	-40 ~+85	°C
Peak pulsing current (1/8 duty f=1kHz)	I _{fp}	125	mA

Electro-optical characteristics

($T_A=25^{\circ}\text{C}$)

Parameter	Test Condition	Symbol	Value			Unit
			Min	Typ	Max	
Wavelength at peak emission	I _f =20mA	λ peak	-	630	-	nm
Spectral half bandwidth	I _f =20mA	$\Delta \lambda$	-	18	-	nm
Dominant wavelength	I _f =20mA	λ dom	620	625	630	nm
Forward voltage	I _f =20mA	V _f	1.7	2.0	2.5	V
Luminous intensity	I _f =20mA	I _v	3200	7000	11200	mcd
Viewing angle at 50% I _v	I _f =10mA	2 θ 1/2	-	30	-	Deg
Reverse current	V _r =5V	I _r	-	-	10	μA

OPTICAL CHARACTERISTIC CURVES

Relative Intensity vs. Wavelength

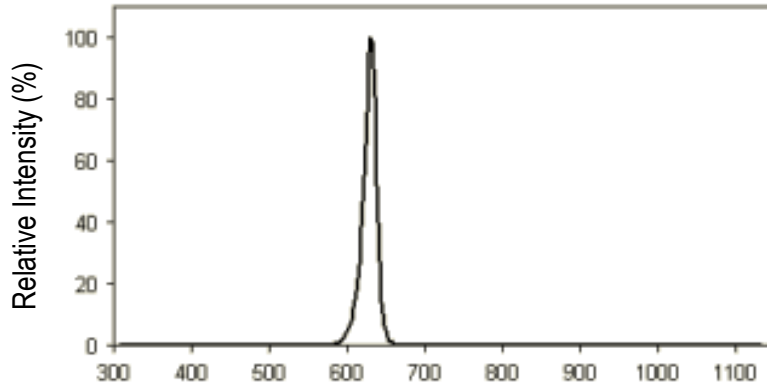

Wavelength (nm)

Forward Current vs. Forward Voltage

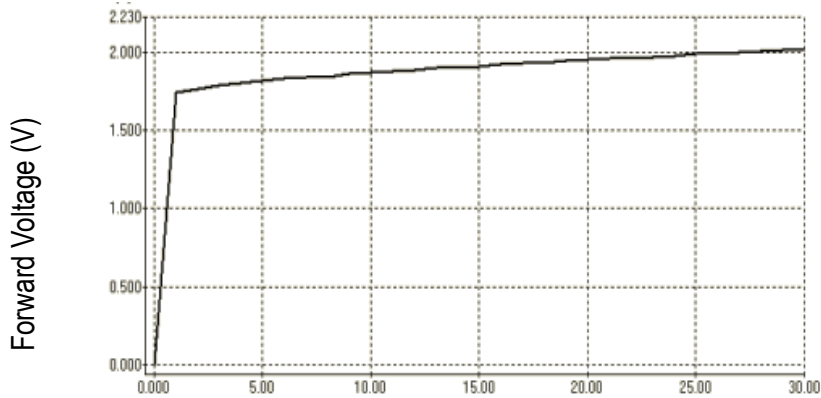

Forward Current (mA)

Directive Characteristics

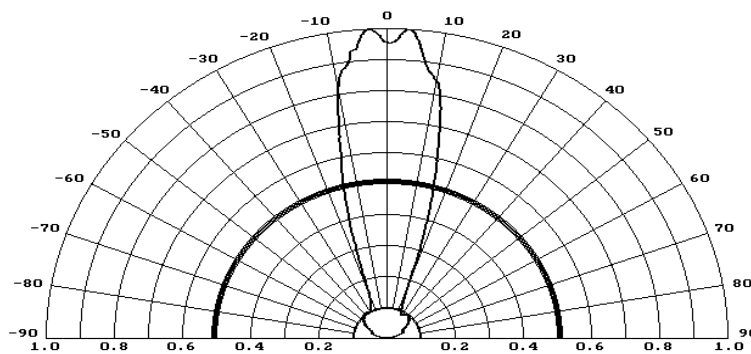

Reflow Profile

■ Reflow Temp/Time

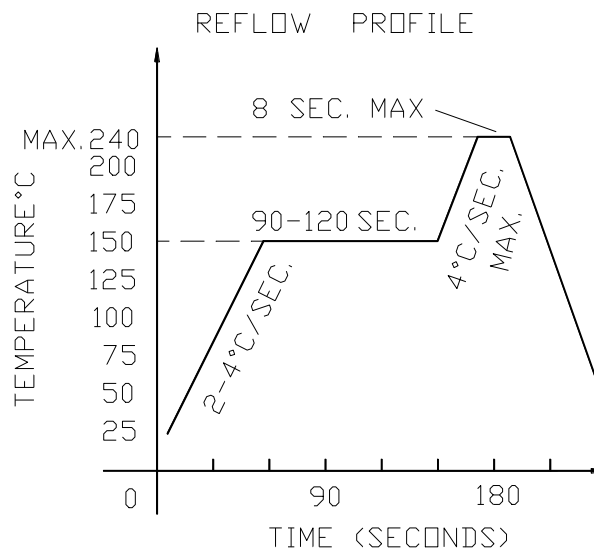

■ Soldering iron

Basic spec is $\leq 5\text{sec}$ when 260°C . If temperature is higher, time should be shorter ($+10^{\circ}\text{C} \rightarrow -1\text{sec}$). Power dissipation of iron should be smaller than 20W, and temperatures should be controllable. Surface temperature of the device should be under 230°C .

Test circuit and handling precautions

■ Test circuit

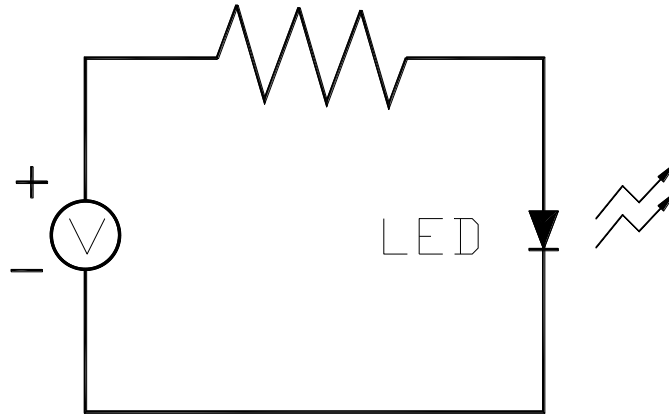

■ Handling precautions

1. Over-current-proof

Customer must apply resistors for protection; otherwise slight voltage shift will cause big current change (Burn out will happen).

2. Shelf life in sealed bag: 12 month at 5°C~30°C and <60% R.H;

3. After the package is Opened:

3.1. It is recommended to baking before the first use:

Baking condition:

a. 60±5°C x (24~48hrs) and <5%RH, taped reel type ;

b. 110±5°C x (8~16hr), bulk type ;

3.2. The products should be used within a week and to be stored at ≤20% R.H. with zip-lock sealed:

a. Baking is required before soldering when the pack is unsealed after 24hrs ;

b. Baking condition as 3.1 baking condition.

3.3 . It is recommended to bake for 24hrs before usage. Recommended baking temperature is 65°C

Test items and results of reliability

Type	Test Item	Test Conditions	Note	Number of Damaged
Environmental Sequence	Temperature Cycle	-20°C 30min ↑ ↓ 80°C 30min	100 cycle	0/22
	Thermal Shock	-20°C 15min ↑ ↓ 80°C 15min	100 cycle	0/22
	High Humidity Heat Cycle	30°C ↔ 65°C 90%RH 24hrs/1cycle	10 cycle	0/22
	High Temperature Storage	T _a =80°C	1000 hrs	0/22
	Humidity Heat Storage	T _a =60°C RH=90%	1000 hrs	0/22
	Low Temperature Storage	T _a =-30°C	1000 hrs	0/22
Operation Sequence	Life Test	T _a =25°C I _F =20mA	1000 hrs	0/22
	High Humidity Heat Life Test	60°C RH=90% I _F =10mA	500 hrs	0/22
	Low Temperature Life Test	T _a =-20°C I _F =20mA	1000 hrs	0/22

3528 Single-Color High Performance SMD Top LEDs Packaging Specifications

● Feeding Direction

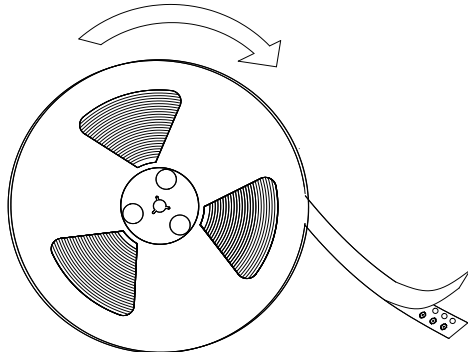

● Dimensions of Reel (Unit: mm)

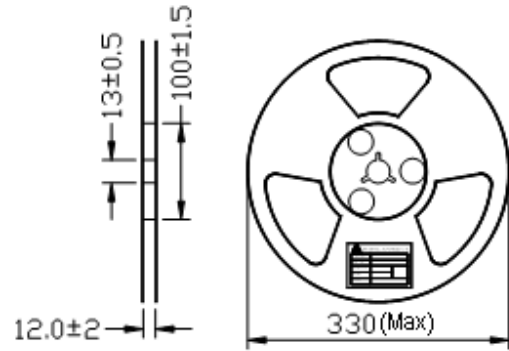

● Dimensions of Tape (Unit: mm)

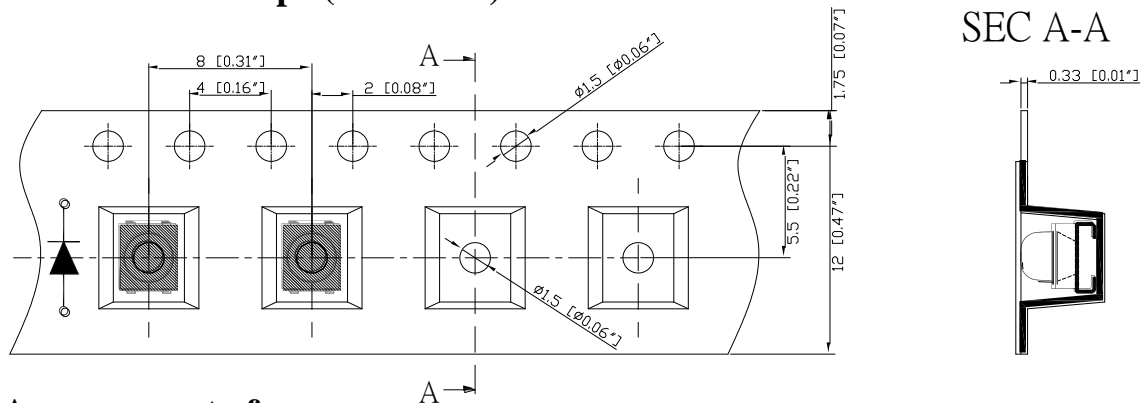

● Arrangement of

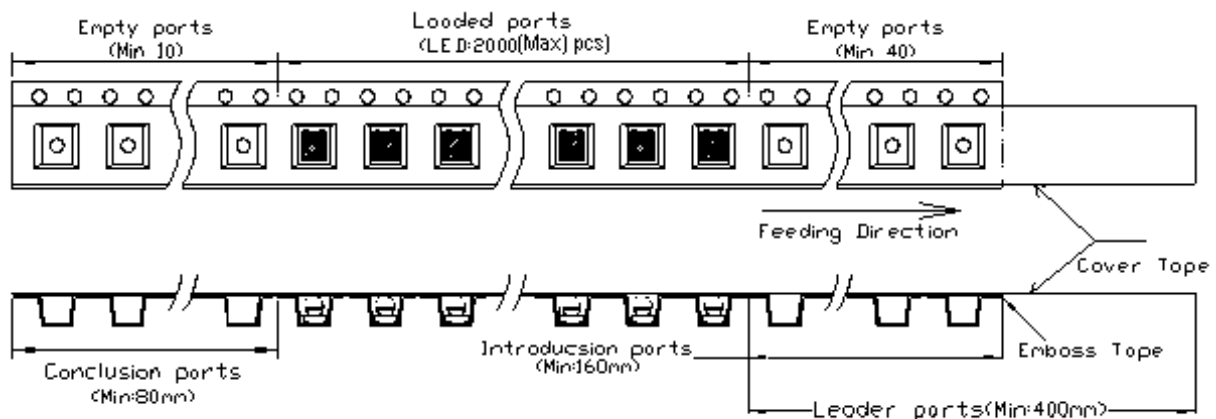

NOT

1. Empty component pockets are sealed with top cover tape;
2. The maximum number of missing lamps is two;
3. The cathode is oriented towards the tape sprocket hole;
4. 2,000(Max)pcs/Reel.

3528 Single-Color High Performance SMD Top LEDs Packaging Specifications

- **Packaging specifications**

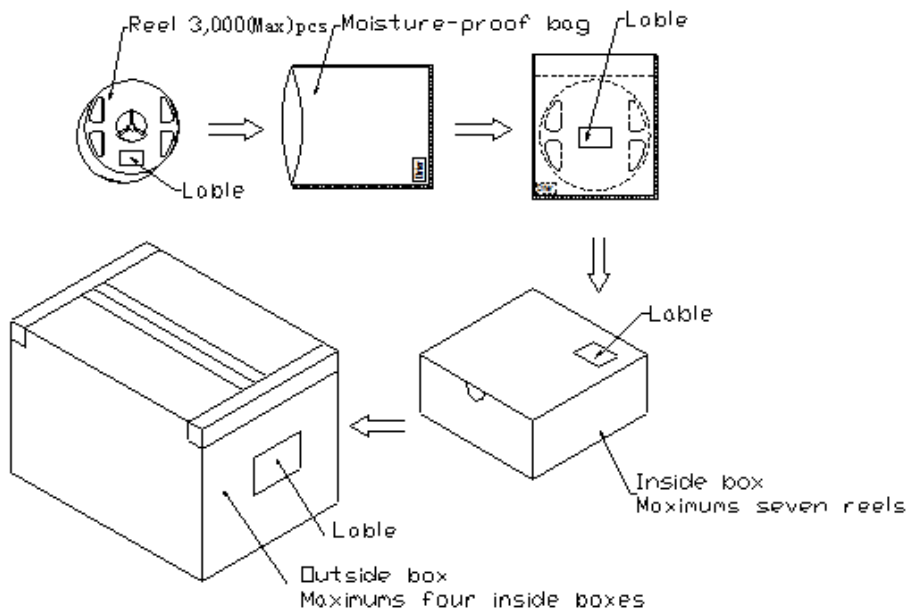

Label

Solidlite Corp.



P/N : _____.

Lot : _____.

Date: _____, Rank: _____.

Q'ty : _____, QA : _____.

NOTES:

Reeled products [numbers of products are 2,000(Max)pcs] packed in a seal off moisture-proof bag along with desiccant and Humidity card one by one, Tow moisture-proof bag of maximums [total maximum number of products are 4,000(Max)pcs] packed in an inside box (size: about 380mm x about 380mm x about 52mm) and ten inside boxes of maximums are put in the outside box (size: about 398mm x about 398mm x about 541mm) Together with buffer material, and it is packed. (Part No., Lot No., quantity should appear on the label on the moisture-proof bag, part No. And quantity should appear on the label on the cardboard box.) The number of the loading steps of outside box (cardboard box) has it to three steps.

Forward Voltage Rank Combination (IF=20mA)

Rank	Min.	Max.	Unit
<input type="checkbox"/>	1.7	2.5	V

Luminous Intensity Rank Combination (IF=20mA)

Rank	Min.	Max.	Unit
Y	3200	4000	mcd
Z	4000	5200	
a	5200	6800	
b	6800	8800	
c	8800	11200	

Dominant wavelength Rank Combination (IF=20mA)

Rank	Min.	Max.	Unit
t	620	625	nm
u	625	630	

Group Name on Label (Example DATA: bt 20)

DATA: <input type="checkbox"/> bt 20	Vf(V)	Iv (mcd)	λ d (nm)	Test Condition
<input type="checkbox"/> →b→t→20	1.7~2.5	6800~8800	620~625	IF=20mA

* NOTE:

1. The tolerance of luminous intensity (Iv)is $\pm 15\%$.
2. The tolerance of dominant wavelength is $\pm 1.5\text{nm}$.
3. This specification is preliminary.