

NOTES:

1. MATERIALS AND FINISHES:
BODY, COUPLING NUT & FERRULE - BRASS, NICKEL PLATING
2. MECHANICAL:
A. DURABILITY: 500 CYCLES MIN.
B. TEMPERATURE RANGE: -65°C TO +165°C
3. PACKAGING:
A. QUANTITY: SINGLE PACK
B. MARKING: BAG TO BE MARKED
"AMPHENOL RF, 83-8SP-1006, AND DATE CODE"
4. CABLE ASSEMBLY INSTRUCTIONS:
A. TRIM CABLE AS SHOWN.
B. SLIDE FERRULE ONTO THE CABLE.
C. INSERT CABLE INTO CONNECTOR.
D. CRIMP WITH AMPHENOL TOOL 227-944 AND DANIELS DIE SET M22520/5-53 (0.454" HEX).

5. SHOWS CABLE ENTRY DIMENSIONS.

THIRD ANGLE PROJ.

REV		DESCRIPTION	DATE	ECO	APPR
--	--	RELEASE TO MFG.	--	--	--
B		REDRAWN IN PRO-E & COD ADDED	7/1/15	49810	KR

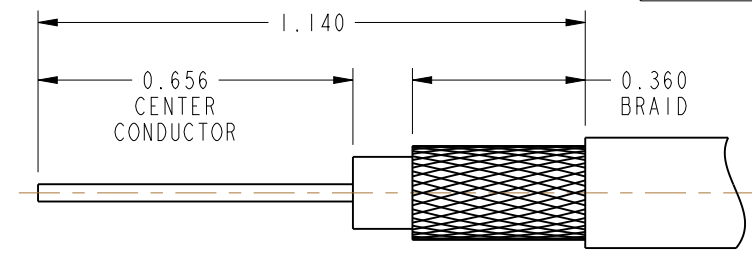

RECOMMENDED CABLE STRIPPING DIMENSIONS

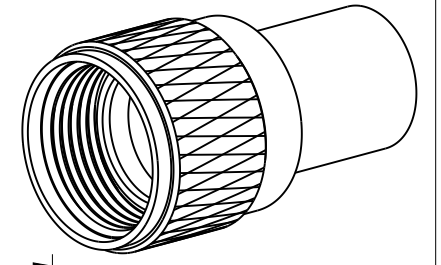

SCALE 1.500

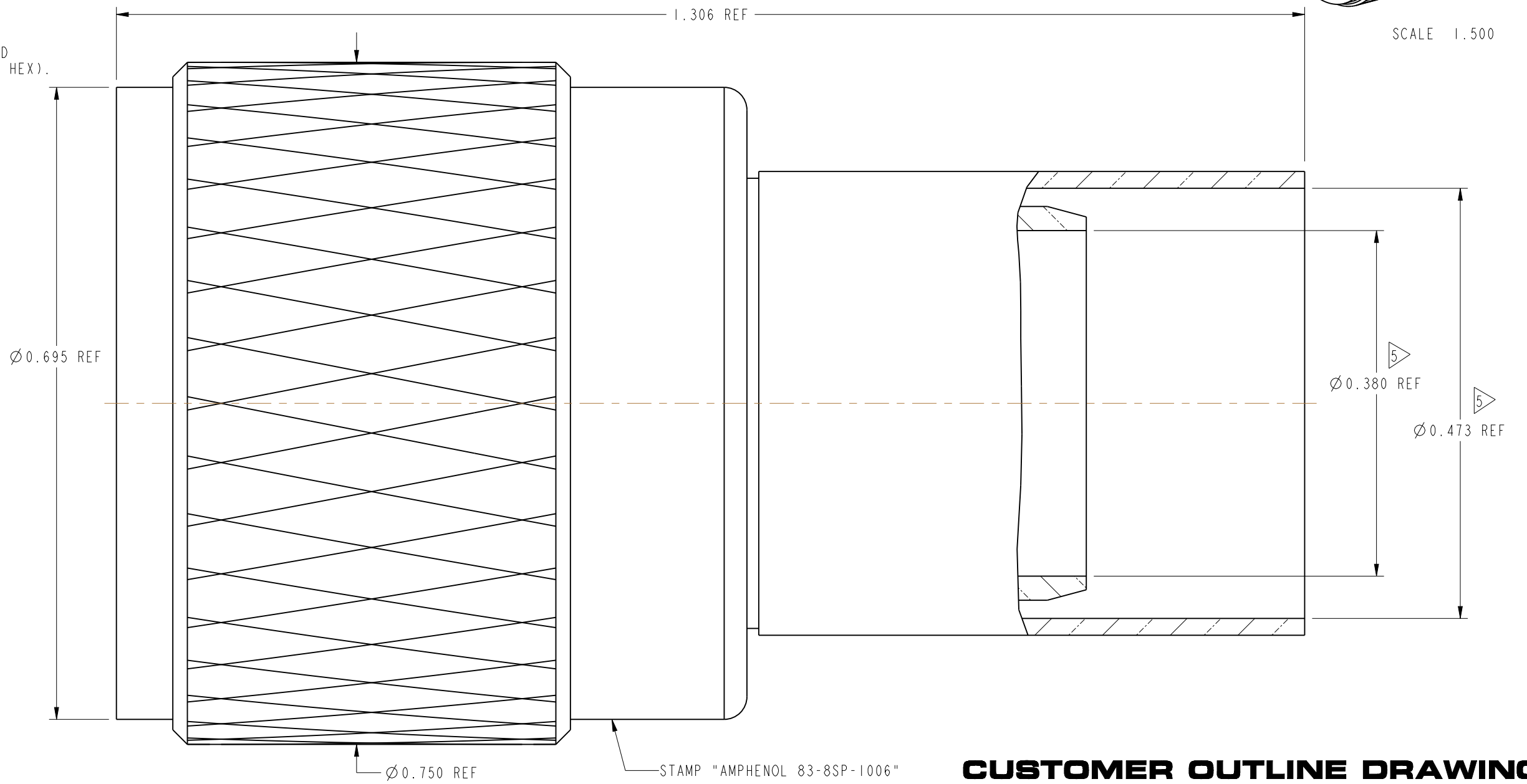

CUSTOMER OUTLINE DRAWING
ALL OTHER SHEETS ARE FOR INTERNAL USE ONLY

UNLESS OTHERWISE SPECIFIED, DIMENSIONS ARE IN INCHES AND TOLERANCES ARE: 2 PLACE DECIMAL 3 PLACE DECIMAL ANGLES ±.015 (0,381 mm) ±.005 (0,127 mm) ± 1°	MATERIAL	DRAWN	DATE	TITLE		Amphenol RF www.amphenolrf.com
	SEE NOTES	KARTHIK R	04-Dec-13	UHF STR PLUG SHV 105714-147 CABLE		
NOTICE - These drawings, specifications, or other data (1) are, and remain the property of Amphenol corp. (2) must be returned upon request; and (3) are confidential and not to be disclosed to any person other than those to whom they are given by Amphenol Corp. the furnishing of these drawings, specifications, or other data by Amphenol Corp., or to any other person to anyone for any purpose is not to be regarded by implication or otherwise in any manner licensing, granting rights to permitting such holder or any other person to manufacture, use or sell any product, process or design, patented or otherwise, that may in any way be related to or disclosed by said drawings, specifications, or other data.	REFERENCE	ENGINEER	DATE	SCALE: 7.6:1.0 SHEET 2 OF 2		DRAWING NO.83-8SP-1006
	EAR # 966655-0 611X-3730	D. ROYCE	15-Aug-97	DWG SIZE B REV B		ITEM NO.83-8SP-1006
	CONFIGURATION LEVEL: In Work FINISH	APPROVED	DATE			PART NO.83-8SP-1006
		K. CAPOZZI	6/30/15			