

OPERATING CHARACTERISTICS AT 25°C AMBIENT													
LED COLOR	LUMINOUS INTENSITY @I _f = 10 mA (mcd)			FORWARD VOLTAGE @I _f = 2 mA (V)		REVERSE CURRENT (μA) V = 12V		DOMINANT WAVELENGTH (nm)			PEAK WAVELENGTH (nm)		
	MIN	TYP	MAX	TYP	MAX	TYP	MAX	MIN	TYP	MAX	TYP		
	591-3001-860F	RED/GRN	RED	—	17	—	1.8	2.2	0.01	10	624	630	636
591-3001-861F	RED/GRN	GREEN	—	13	—	—	—	—	—	566	570	575	572
591-3101-862F	YLW/GRN	YELLOW	—	20	—	1.8	2.2	0.01	10	580	587	595	591
591-3101-863F	YLW/GRN	GREEN	—	13	—	—	—	—	—	566	570	575	572

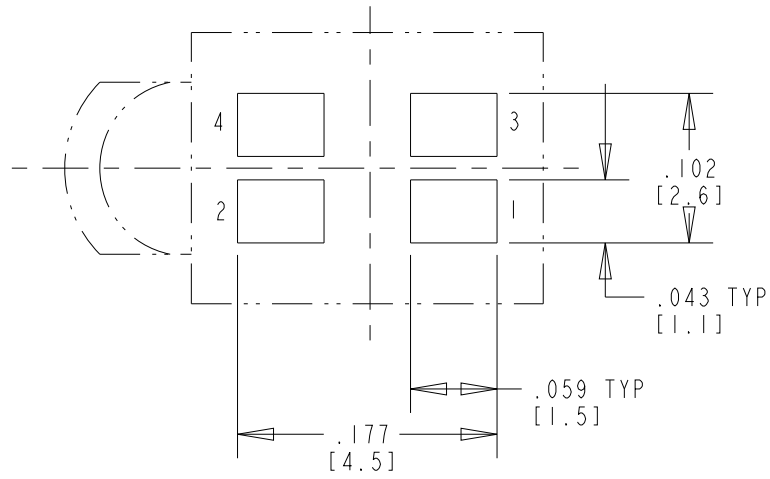

COMPONENT SIDE
RECOMMENDED PC BOARD LAND PATTERN
(DIM'S ± .004)

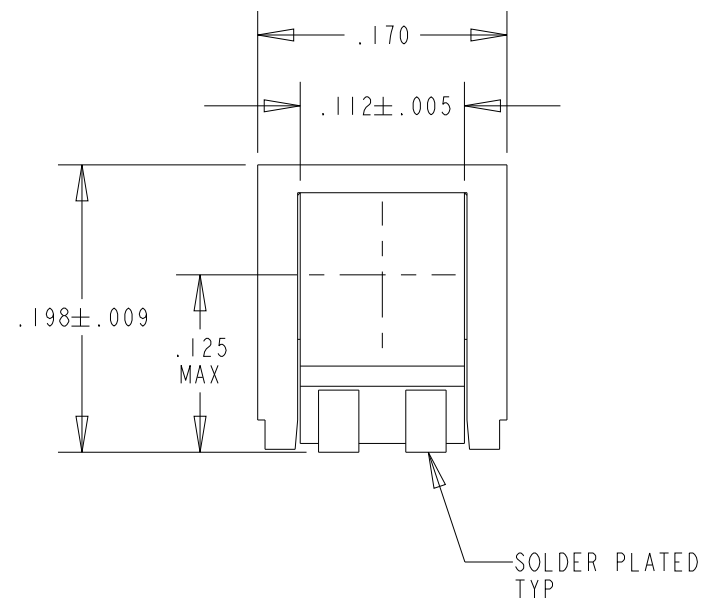
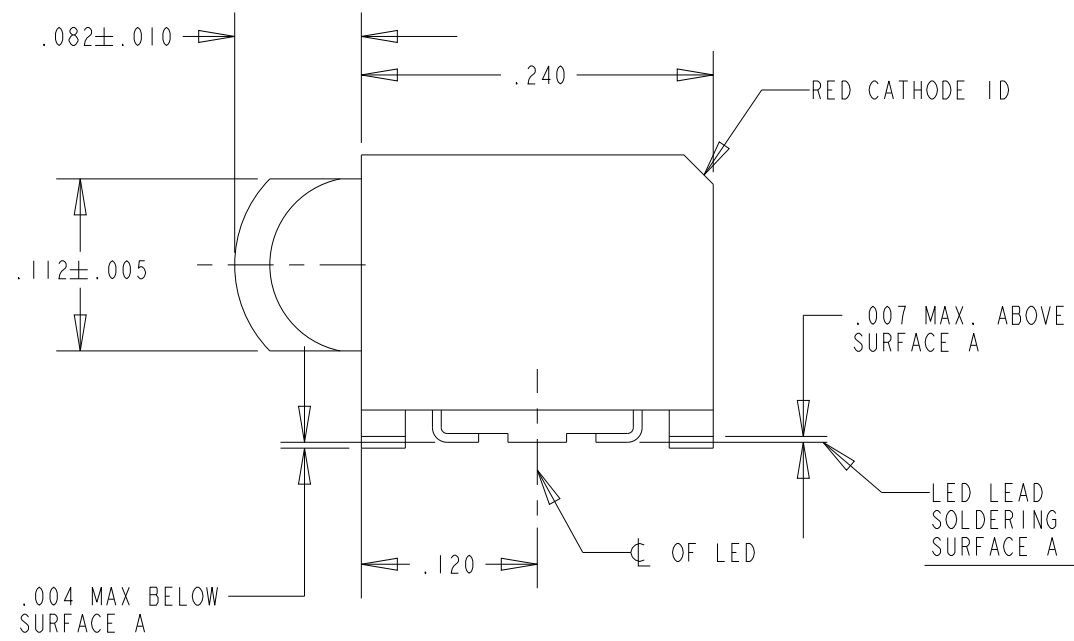

ABSOLUTE MAXIMUM RATINGS AT 25°C AMBIENT	RED/GRN	YLW/GRN	UNITS
CONTINUOUS FORWARD CURRENT	15		mA
REVERSE VOLTAGE	12		V
SURGE CURRENT	100		mA
PEAK SOLDERING TEMPERATURE	245		°C
OPERATING TEMPERATURE	-40 TO +100		°C
STORAGE TEMPERATURE	-40 TO +100		°C
TIME ABOVE LIQUIDUS TEMPERATURE (t _L)	80 Seconds Minimum 100 Seconds Maximum		s
TIME WITHIN 5°C OF SPECIFIED PEAK TEM (T _P - 5°C)	10 Seconds Minimum 30 Seconds Maximum		s
PEAK TEMPERATURE T _P	245 Recommended 260 Maximum		°C
RAMP-UP RATE TO PREHEAT (25°C TO 150°C)	2 °C/s Recommended 3 °C/s Max		°C/s
RAMP-UP RATE TO PEAK (T _{max} to T _P)			
RAMP-DOWN RATE (T _P to 100°C)	3 °C/s Recommended 6 °C/s Max		°C/s
TIME (25°C to T _P)	480 Seconds Maximum		s

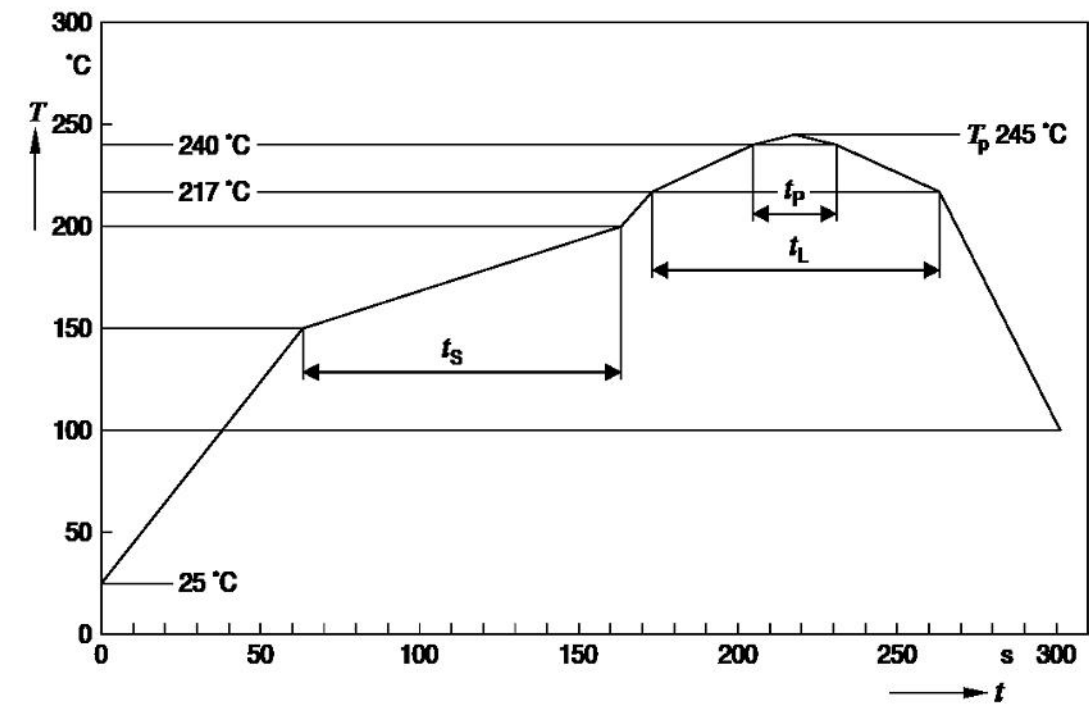

RECOMMENDED SOLDER PROFILE

NOTES:

- MILLIMETER DIMENSIONS SHOWN FOR REFERENCE ONLY.
- PAD NUMBERS FOR REFERENCE ONLY. DESIGNATION NON-EXISTENT ON PART.
- STORAGE CONDITIONS FOR TAPED PRODUCT: RE-TAPING MAY BE NECESSARY FOR PRODUCT STORED MORE THAN TWELVE MONTHS.
- 860F & 862F SUFFIX MEANS PARTS ARE PACKED ON A 13 INCH REEL, 1600 PCS/REEL. -861F & 863F SUFFIX MEANS PARTS ARE PACKED ON A 7 INCH REEL, 400 PCS/REEL
- LENS MOVEMENT IN RELATIONSHIP TO THE HOUSING IS:
.009" T.I.R. VERTICALLY.
.007" T.I.R. HORIZONTALLY.
- FRONT AND REAR TERMINALS OF ASSEMBLY TO BE WITHIN .005 COPLANARITY.
- DIALIGHT PART NUMBER: 591-3001-860F, 591-3001-861F, 591-3101-862F, 591-3101-863F
- DEVICE HAS A MOISTURE SENSITIVITY LEVEL "2" CAUTION LABEL APPLIED AS PER JEDEC STD. 033.
- THIS PRODUCT IS RoHS COMPLIANT (Pb FREE). EACH BAG AND REEL IS MARKED WITH THE RoHS COMPLIANT LABEL P/N 9100-117-0852-99 OR EQUIVALENT MARKINGS.

TAPING SPECIFICATION

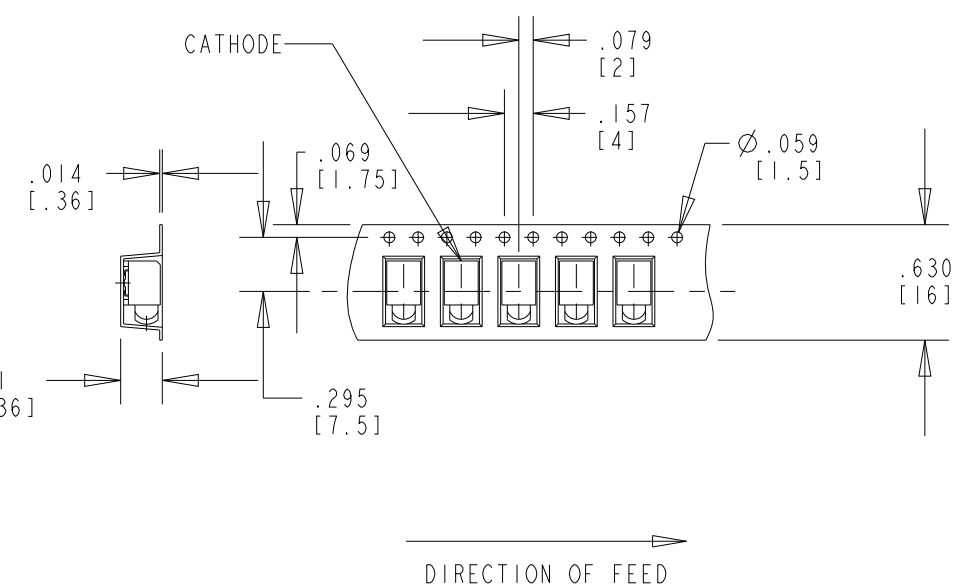

TOLERANCE: .004 UNLESS OTHERWISE SPECIFIED.
MILLIMETER DIMENSIONS SHOWN FOR REFERENCE ONLY.

REEL SPECIFICATION

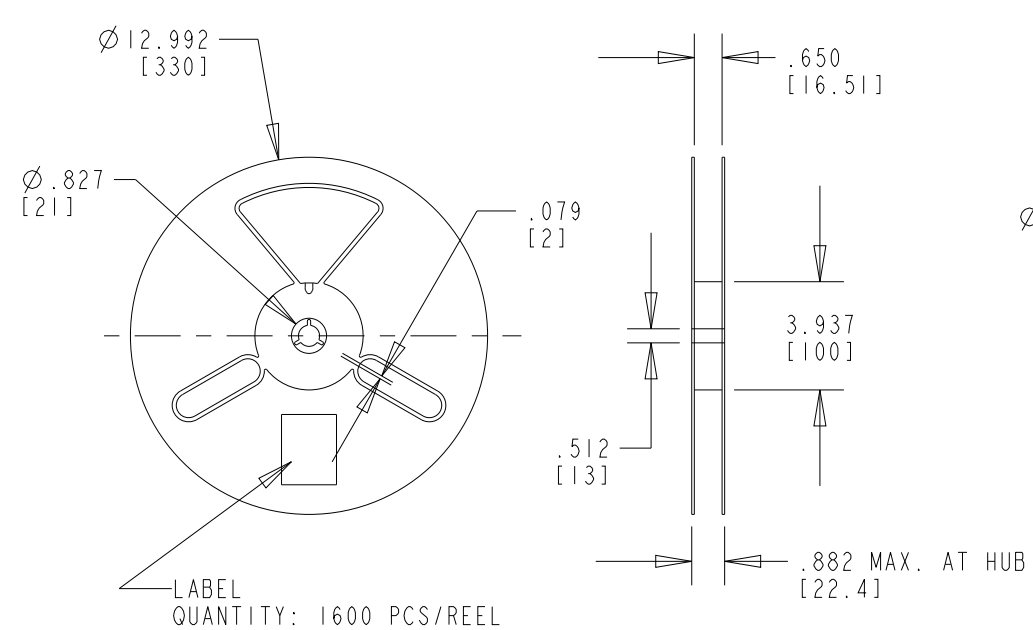

13 INCH DIA. REEL SPECIFICATIONS

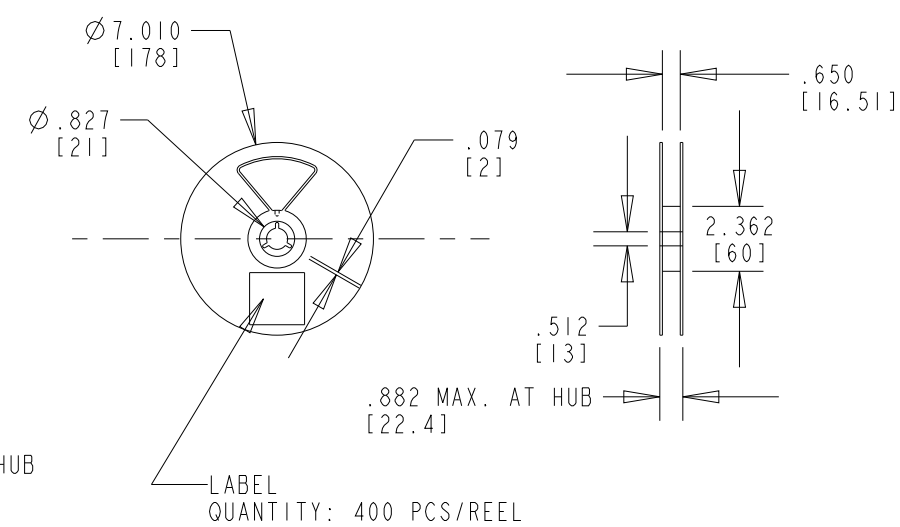

7 INCH DIA. REEL SPECIFICATIONS

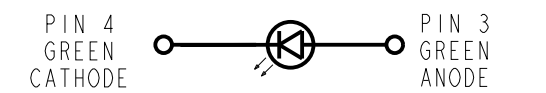

LED SCHEMATIC FOR R/G

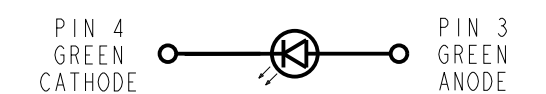

LED SCHEMATIC FOR Y/G

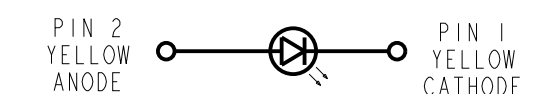
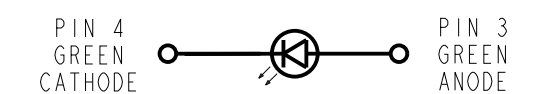

THIS DRAWING AND THE CONTENTS HEREIN ARE CONFIDENTIAL AND THE SOLE PROPERTY OF DIALIGHT CORP. REPRODUCTION OF THIS DRAWING OR CONSTRUCTION OF ANY PARTS WITHIN THIS DRAWING ARE FORBIDDEN WITHOUT THE WRITTEN CONSENT OF DIALIGHT CORP.

SCALE: DRAWING SCALE	DRAWING NUMBER	REV
ALL DIM'S IN: INCHES (MM)	C-18341	B
TOLERANCES: UNLESS OTHERWISE SPECIFIED	TITLE 3mm PRISM R/G, Y/G (LOW CURRENT) ROUND LENS, RoHS COMPLIANT	
FRACTIONS: ±1/64	MATERIAL	
DECIMALS (.XX): ±.01	FINISH	
DECIMALS (.XXX): ±.005	FSCM 83330	
DECIMALS (.XXXX): ±.0005	SHEET 1 OF 1 FAMILY TABLE:	
ANGLES: ±1°	Dialight 1501 ROUTE 34 SOUTH FARMINGDALE, NJ 07727 (732) 919-3119 www.dialight.com	