

● Features:

1. Chip material: AlGaInP/GaAs (Red) and InGaN (Green)
2. Emitted color : Super Red and Green
3. Lens Appearance : White Diffused
4. Low power consumption.
5. High efficiency.
6. Versatile mounting on P.C. Board or panel.
7. Low current requirement.
8. 5mm diameter package.
9. This product don't contained restriction substance, compliance RoHS standard.

● Applications:

1. TV set
2. Monitor
3. Telephone
4. Computer
5. Circuit board

● Package dimensions

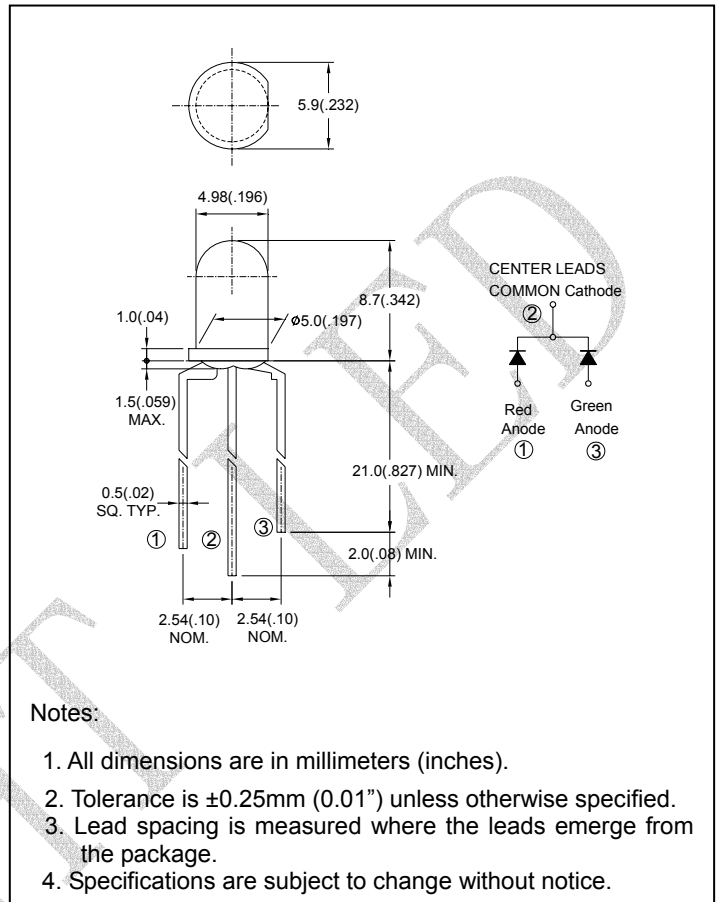

● Absolute Maximum Ratings(Ta=25°C)

Parameter	Symbol	Super Red	Green	Unit
Power Dissipation	Pd	80	110	mW
Forward Current	I _F	30	30	mA
Peak Forward Current* ¹	I _{FP}	150	150	mA
Reverse Voltage	V _R	5		V
Operating Temperature	Topr	-40°C~85°C		
Storage Temperature	Tstg	-40°C~85°C		

*¹Condition for I_{FP} is pulse of 1/10 duty and 0.1msec width.

● **Electrical and optical characteristics(Ta=25°C)**

Parameter	Symbol	Condition	Color	Min.	Typ.	Max.	Unit
Forward Voltage	V_F	$I_F=20\text{mA}$	Red Green	-	2.0 3.2	2.6 3.6	V
Luminous Intensity	I_v	$I_F=20\text{mA}$	Red Green	-	310 1500	-	mcd
Reverse Current	I_R	$V_R=5\text{V}$	Red Green -	-		100	μA
Peak Wave Length	λ_p	$I_F=20\text{mA}$	Red Green	-	645 525	-	nm
Dominant Wave Length	λ_d	$I_F=20\text{mA}$	Red Green	625 520	- -	637 535	nm
Spectral Line Half-width	$\Delta\lambda$	$I_F=20\text{mA}$	Red Green	-	20 35	-	nm
Viewing Angle	$2\theta_{1/2}$	$I_F=20\text{mA}$	Red Green	-	50	-	deg

● **Typical Electro-Optical Characteristics Curves**

Fig.1 Relative intensity vs. Wavelength

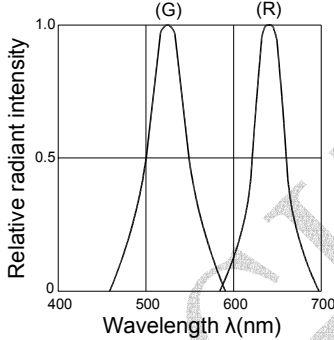

Fig.2 Forward current derating curve vs. Ambient temperature

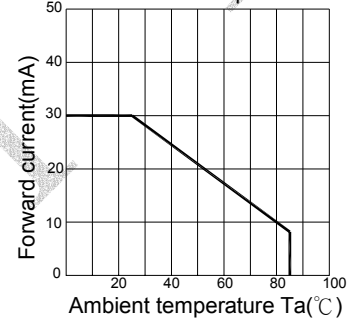

Fig.3 Forward current vs. Forward voltage

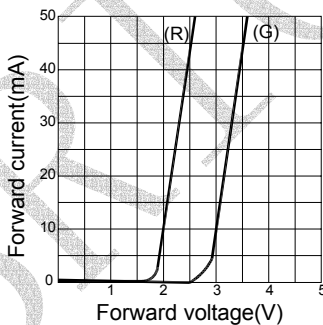

Fig.4 Relative luminous intensity vs. Ambient temperature

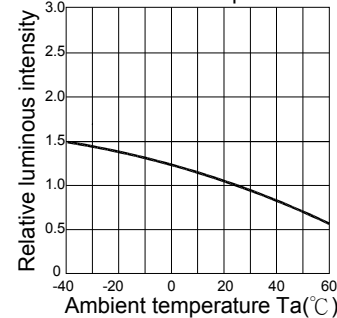

Fig.5 Relative luminous intensity vs. Forward current

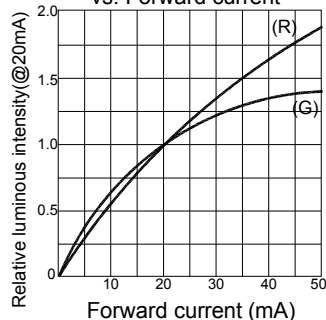
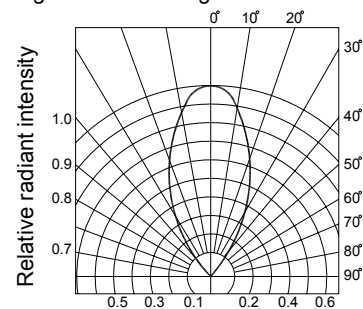

Fig.6 Radiation diagram





● Bin Limits(Green)

1. Intensity Bin Limits (At $I_F=20\text{mA}$)

Bin Code	Min. (mcd)	Max. (mcd)
U	475	715
V	715	1070
W	1070	1600
X	1600	2400
Y	2400	3700

2. Color Bin Limits (At $I_F=20\text{mA}$) : Dominant Wave Length $\lambda_d(\text{nm})$

Bin Code	Min. (nm)	Max. (nm)
6	520	525
7	525	530
8	530	535

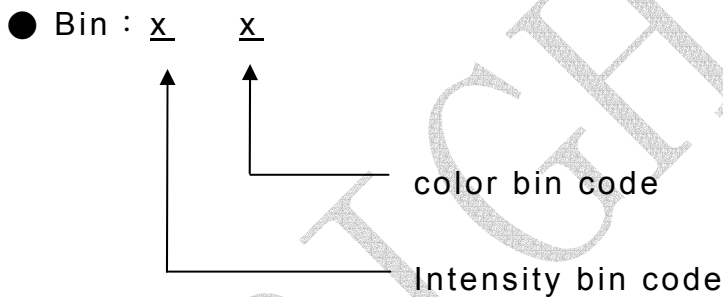

NOTES:1.Tolerance of measurement of luminous intensity. $\pm 15\%$

2.Tolerance of measurement of dominant wavelength $\pm 1.0\text{nm}$



● PACKAGING DIMMENSIONS

1. PACKAGING BOX DIMENSIONS:

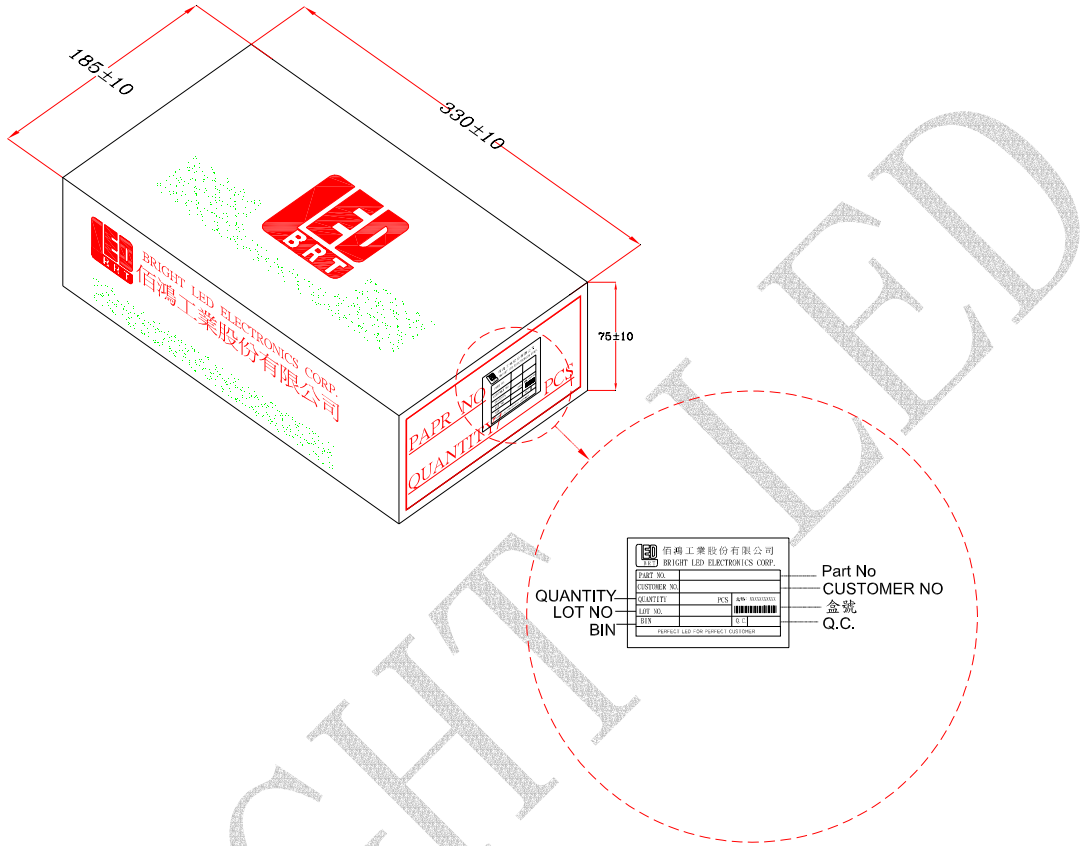

2. PACKAGING BAG DIMENSIONS

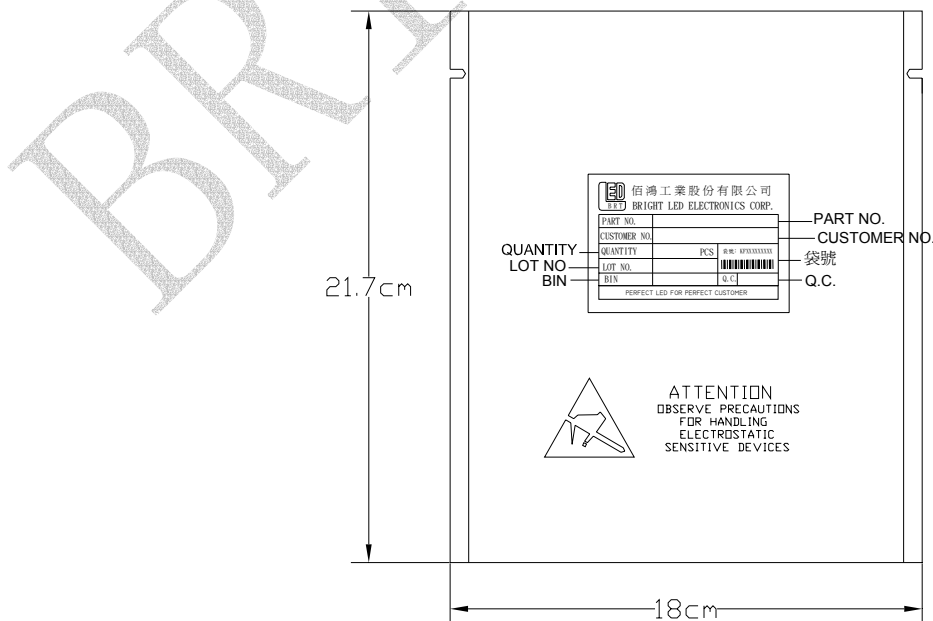

3. PACKAGING CARTON DIMENSIONS

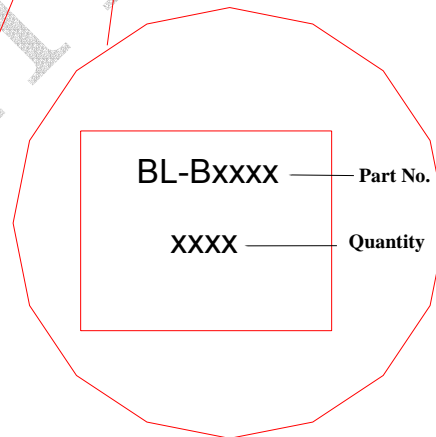
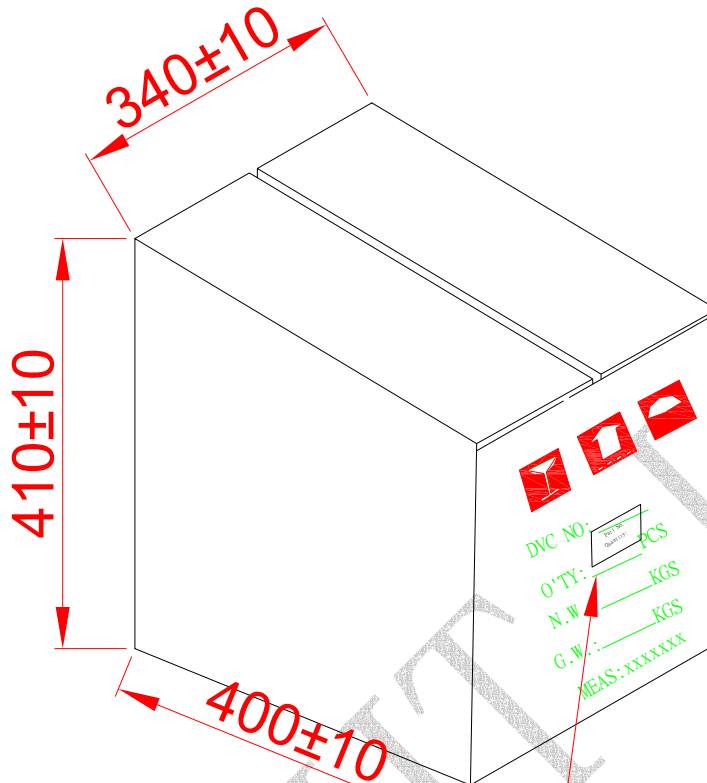

NOTES:

1. 2.5K PCS PER BOX, 250 PCS PER BAG, 25K PCS PER CARTON
2. ALL Dimensions are in millimeters (inches).
3. Specifications are subject to change without notice.



● Reliability Test

Classification	Test Item	Reference Standard	Test Conditions	Result
Endurance Test	Operation Life	MIL-STD-750:1026 MIL-STD-883:1005 JIS-C-7021 :B-1	I _F =20mA T _a =+25°C±5°C Test time=1,000hrs	0/32
	High Temperature High Humidity Storage	MIL-STD-202:103B JIS-C-7021 :B-11	T _a =+85°C±5°C RH=90%-95% Test time=240hrs	0/32
	High Temperature Storage	MIL-STD-883:1008 JIS-C-7021 :B-10	High T _a =+85°C±5°C Test time=1,000hrs	0/32
	Low Temperature Storage	JIS-C-7021 :B-12	Low T _a =-45°C±5°C Test time=1,000hrs	0/32
Environmental Test	Temperature Cycling	MIL-STD-202:107D MIL-STD-750:1051 MIL-STD-883:1010 JIS-C-7021 :A-4	T _a : +85°C (30min) ~ +25°C (5min) ~ -45°C (30min) ~ +25°C (5min) Test Time : 70min/ctcle 10cycle	0/32
	Thermal Shock	MIL-STD-202:107D MIL-STD-750:1051 MIL-STD-883:1011	-45°C±5°C ~+85°C±5°C 20min 20min Test Time=10cycle	0/32
	Solder Resistance	MIL-STD-202:201A MIL-STD-750:2031 JIS-C-7021 :A-1	Preheating : 120°C, within 120-180 sec. Operation heating : 255°C±5°C within 5 sec. 260°C (Max)	0/32
	Solderability	MIL-STD-202F:208D MIL-STD-750D:2026 MIL-STD-883D:2003 JIS C 7021:A-2	T _{sol} =230±5°C Dwell Time=5±1secs	0/32

● Judgment criteria of failure for the reliability

Measuring items	Symbol	Measuring conditions	Judgment criteria for failure
Forward voltage	V _F (V)	I _F =20mA	Over U ¹ x1.2
Reverse current	I _R (uA)	V _R =5V	Over U ¹ x2
Luminous intensity	I _v (mcd)	I _F =20mA	Below S ¹ X0.5

Note: 1. U means the upper limit of specified characteristics. S means initial value.

2. Measurement shall be taken between 2 hours and after the test pieces have been returned to normal ambient conditions after completion of each test.

● Dip Soldering

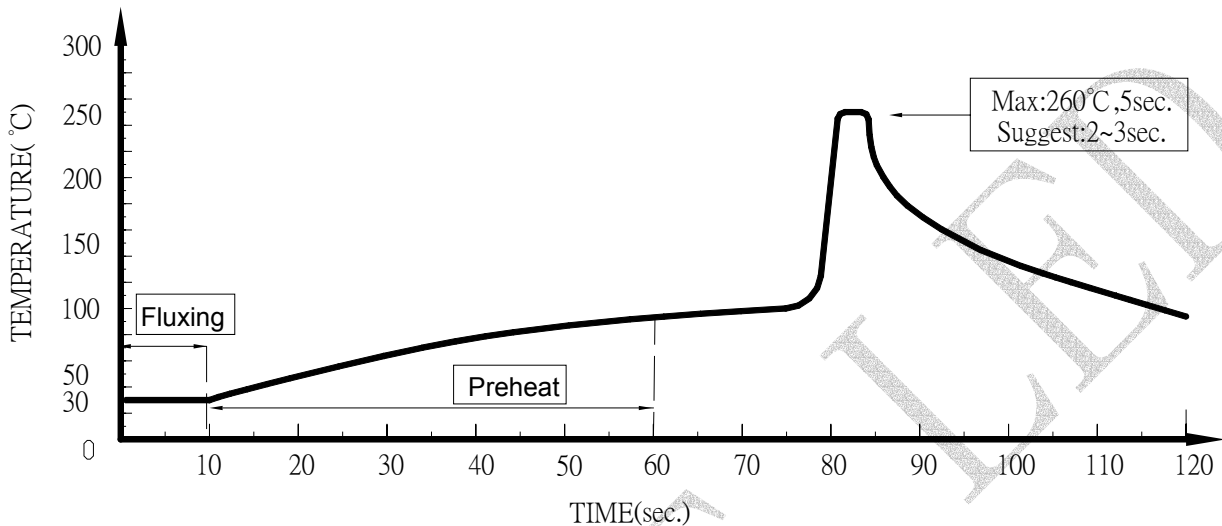

1. Please avoid any external stress applied to the lead-frames and epoxy while the LEDs are at high temperature, especially during soldering
2. DIP soldering and hand soldering should not be done more than one time.
3. After soldering, avoid the epoxy lens from mechanical shock or vibration until the LEDs are back to room temperature.
4. Avoid rapid cooling during temperature ramp-down process
5. Although the soldering condition is recommended above, soldering at the lowest possible temperature is feasible for the LEDs

● IRON Soldering

A : Max : 350°C Within 3 sec. One time only.

B : The products of 3mm without flange, welding condition of flat plate PCB Max : 350°C Within 2 sec. One time only

