

Device Features

- Gain = 14.7 dB @ 900MHz
- OIP3 = 39.7 dBm @ 900 MHz
- Output P1 dB = 20.5 dBm @ 900 MHz
- N.F = 1.85dB @ 900 MHz
- Internally matched to 50 ohms
- RoHS2-compliant SOT-89 SMT package



Product Description

The BBA03 is a BroadBand, GaAs E-pHEMT Amplifier that is ideal for applications demanding high linearity and gain flatness in a bandwidth of 30-6000 MHz. The BBA03 is internally matched to 50 Ohms and requires no external matching components. It is available in RoHS2-compliant SOT-89 SMT package. These devices are 100% DC and RF tested to assure quality and performance.

Applications

- Repeaters
- Mobile Infrastructure
- Defense/Aerospace
- LTE / WCDMA / EDGE / CDMA
- General Purpose Wireless
- IF amplifier, RF driver amplifier

Applications Circuit

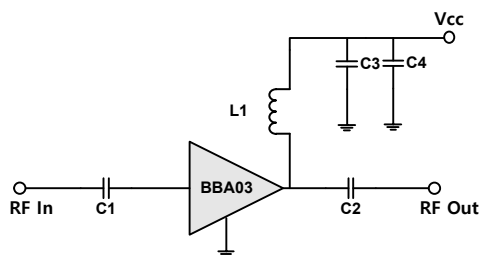

BOM @GHz	0.03~1.5	0.5~4.0	1.5~5.0	5.0~6.0
C1	2.2nF	100pF	22pF	10pF
C2	2.2nF	100pF	22pF	10pF
C3	100pF	100pF	100pF	100pF
C4	1uF	1uF	1uF	1uF
L1	1uH	22nH	5.6nH	3.3nH

Electrical Specifications

Device performance _ measured on a BeRex evaluation board at 25°C, Vd=5V, 50 Ω system.

Parameter	Conditions	Min	Typ	Max	Unit
Operational Frequency Range		30		6000	MHz
Test Frequency			900		MHz
Gain		13.2	14.7		dB
Input Return Loss			-14.3		dB
Output Return Loss			-12.6		dB
Output IP3	6 dBm / tone , Δf=1 MHz	36.7	39.7		dBm
Output P1dB		19.5	20.5		dBm
LTE 20M ACLR*		9.5	10.5		dBm
Noise Figure			1.85		dB

*ACLR Channel Power measured at -50dBc.

- LTE set-up: 3GPP LTE, FDD E-TM3.1, 20MHz BW, ±20MHz offset, PAR 9.75 at 0.01% Prob.

Recommended Operating Conditions

Parameter	Min	Typ	Max	Unit
Bandwidth	30		6000	MHz
I _d @ (V _d = 5V)	80	100	120	mA
V _d	4.75	5.0	5.25	V
dG/dT		-0.003		dB/°C
R _{TH}		40.1		°C/W
Operating Case Temperature	-40		+105	°C

Electrical specifications are measured at specified test conditions.

Specifications are not guaranteed over all recommended operating conditions.

Absolute Maximum Ratings

Parameter	Rating	Unit
Storage Temperature	-55 to +155	°C
Junction Temperature	+170	°C
Supply Voltage	+7	V
Supply Current	190	mA
Input RF Power	20	dBm

Operation of this device above any of these parameters may result in permanent damage.

Typical Performance (Vd=5V, Id=100mA, T=25°C)

Parameter	Frequency						Unit
	100	900	1800	2140	2650	3500	
Gain	15.0	14.7	14.6	14.6	14.5	14.0	dB
S11	-17.0	-14.3	-19.1	-26.2	-14.1	-8.7	dB
S22	-16.3	-12.6	-14.9	-25.9	-14.7	-7.6	dB
OIP3	40.1	39.7	37.2	37.5	36.5	35.0	dBm
P1dB	20.5	20.5	20.1	20.0	19.0	18.0	dBm
LTE 20M ACLR*	11.9	10.5	9.3	9.3	8.6	8.3	dBm
5G NR ACLR*	-	-	-	-	-	8.0	dBm
Noise Figure	1.85	1.85	1.95	2.1	2.1	2.3	dB

*ACLR Channel Power measured at -50dBc.

- LTE set-up: 3GPP LTE, FDD E-TM3.1, 20MHz BW, ±20MHz offset, PAR 9.75 at 0.01% Prob.

- 5G set-up: 3GPP 5G NR, 100MHz BW, ±100MHz offset, PAR 9.5 at 0.01% Prob.

V-I Characteristics

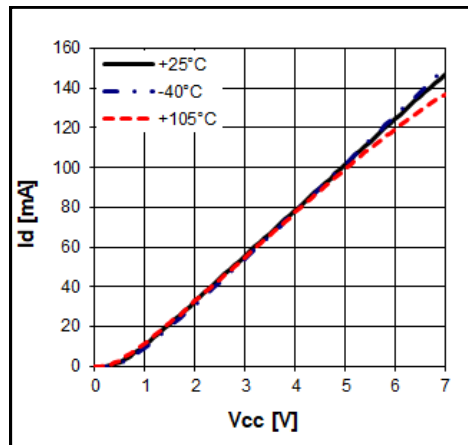

BeRex SOT89 Evaluation Board

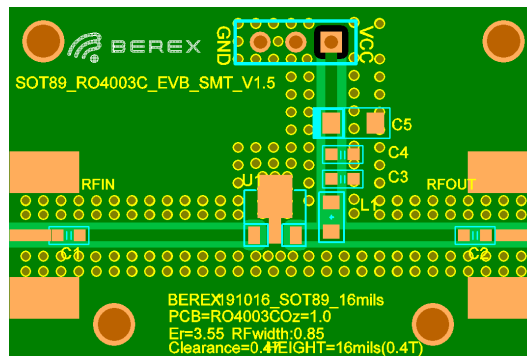

*Dielectric constant _ 3.55 *RF pattern width 0.85T *0.4T thick RO4003 PCB

Wideband Performance (Vd=5V, Id=100mA, T=25°C)

Parameter	Frequency						Unit
	50	100	250	500	900	1500	
Gain	15.3	15.0	14.9	14.8	14.7	14.1	dB
S11	-13.4	-17.0	-19.6	-22.3	-39.8	-14.8	dB
S22	-17.3	-16.3	-16.4	-17.7	-20.4	-13.0	dB
OIP3	36.9	40.1	40.3	40.0	37.7	35.5	dBm
P1dB	20.8	20.5	20.9	21	20.6	20.4	dBm
LTE 20M ACLR*	-	11.9	12	12	11.4	11	dBm
Noise Figure	1.6	1.85	1.85	1.85	1.85	1.85	dB

Parameter	Frequency						Unit
	500	900	1800	2140	2650	3500	
Gain	14.4	14.7	14.6	14.1	14.0	14.0	dB
S11	-11.5	-14.3	-20.2	-13.7	-9.8	-9	dB
S22	-9.5	-12.6	-23.2	-13.9	-9.4	-8.2	dB
OIP3	40.0	39.7	36.5	36.0	35.0	35.0	dBm
P1dB	20.4	20.5	20.1	20	19.5	19.0	dBm
LTE 20M ACLR*	11.1	10.5	10.3	10.3	9.8	9.4	dBm
5G NR ACLR*	-	-	-	-	-	9.0	dBm
Noise Figure	1.85	1.85	1.95	2.1	2.1	2.2	dB

*ACLR Channel Power measured at -50dBc.

- LTE set-up: 3GPP LTE, FDD E-TM3.1, 20MHz BW, ±20MHz offset, PAR 9.75 at 0.01% Prob.

- 5G set-up: 3GPP 5G NR, 100MHz BW, ±100MHz offset, PAR 9.5 at 0.01% Prob.

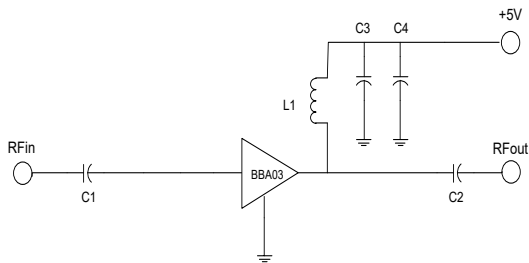

BOM @GHz	0.03~1.5	0.5~4.0	Remark
C1	2.2nF	100pF	0603
C2	2.2nF	100pF	0603
C3	100pF	100pF	0603
C4	1uF	1uF	0603
L1	1uH	22nH	0603

Typical Device Data

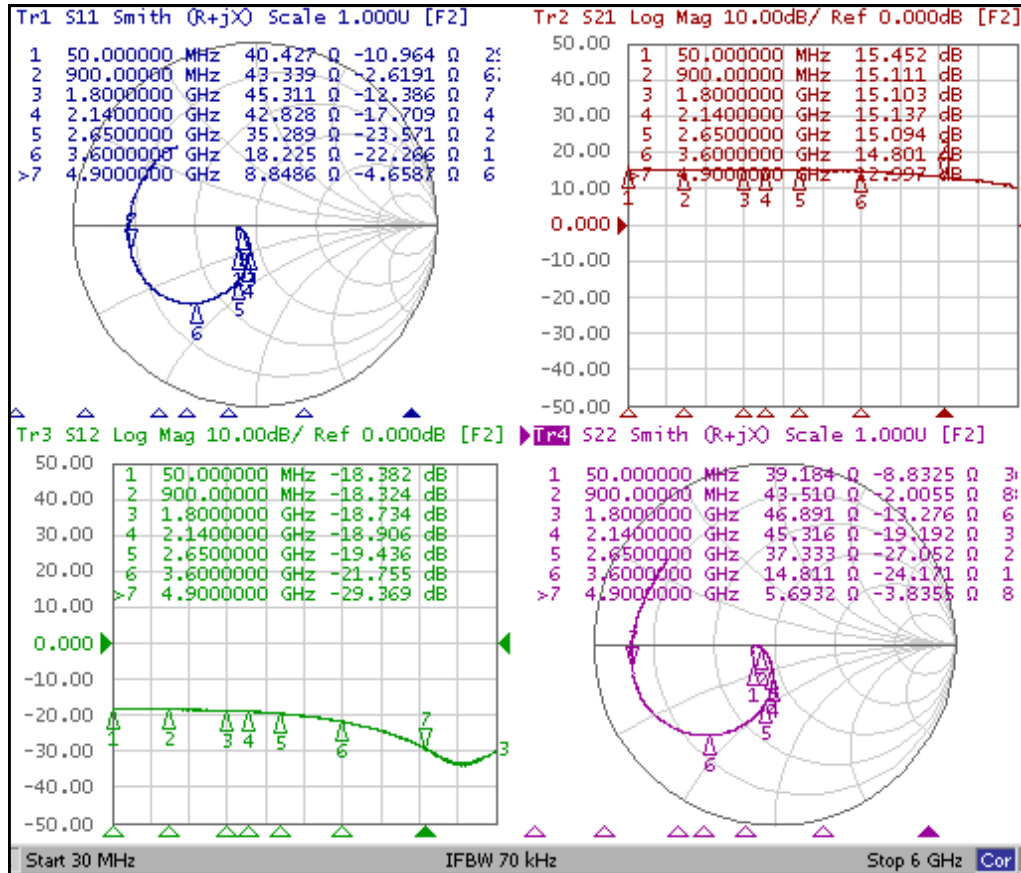
 S-parameters (V_d=5V, I_d=100mA, T=25°C)

S-Parameter

 (V_{device} = 5.0V, I_d = 100mA, T = 25 °C, calibrated to device leads)

Freq [MHz]	S11 [Mag]	S11 [Ang]	S21 [Mag]	S21 [Ang]	S12 [Mag]	S12 [Ang]	S22 [Mag]	S22 [Ang]
200	0.11	-160.87	5.72	169.37	0.122	-2.93	0.12	-168.17
400	0.10	-169.18	5.70	162.61	0.121	-8.25	0.11	-175.47
1200	0.08	-135.77	5.70	130.75	0.120	-29.30	0.07	-131.45
2000	0.18	-101.35	5.71	97.42	0.114	-51.79	0.18	-93.41
2800	0.36	-108.33	5.64	61.99	0.104	-78.11	0.37	-100.82
3600	0.54	-126.85	5.48	26.39	0.081	-108.66	0.62	-125.34
4400	0.67	-150.13	4.92	-9.15	0.054	-146.29	0.78	-153.55
5200	0.70	177.78	4.20	-45.35	0.025	149.64	0.79	177.19
6000	0.61	135.16	3.33	-76.23	0.033	43.20	0.76	139.56

Application Circuit: 100 MHz

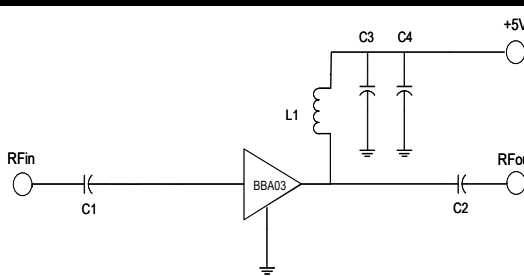
Schematic Diagram		BOM		Size
		C1	2.2nF	0603
		C2	2.2nF	0603
		C3	100pF	0603
		C4	1uF	0603
		L1	1uH	0603

Typical Performance (Vd=5V, Id=100mA, T=25°C)

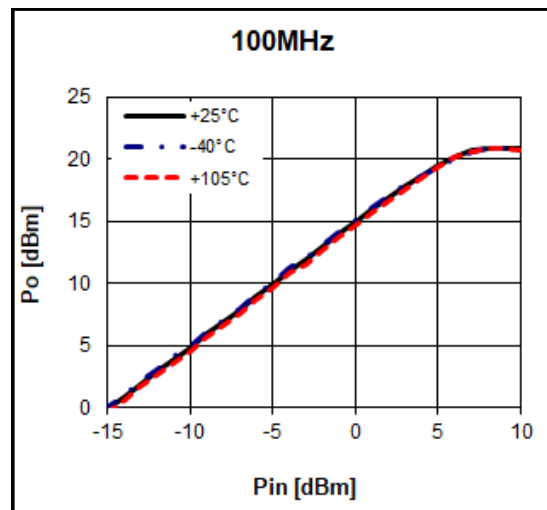
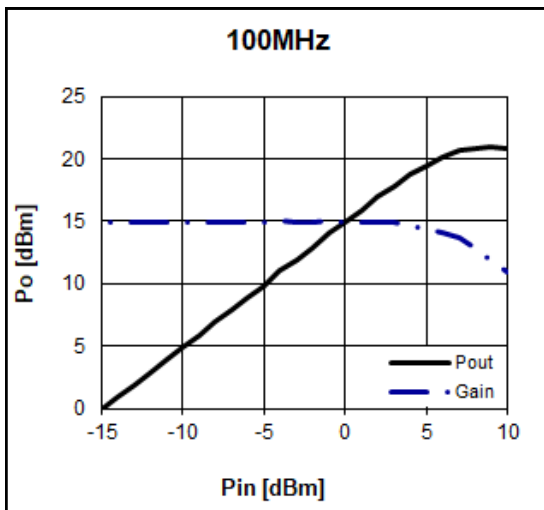

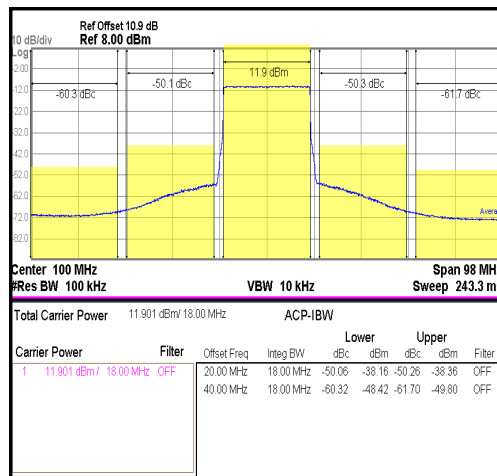
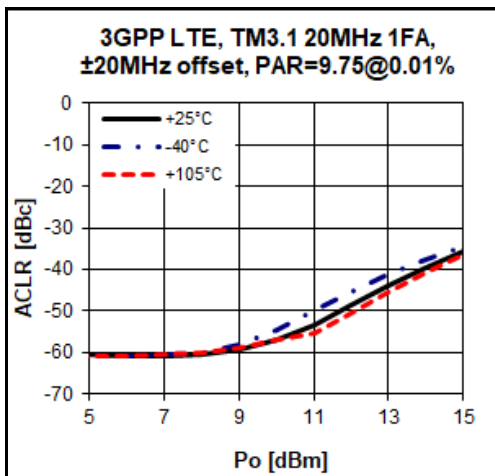
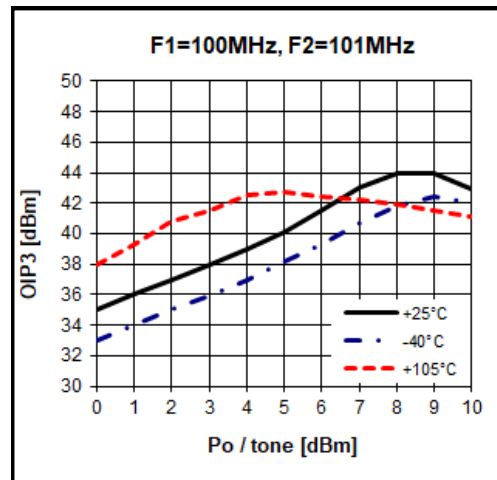
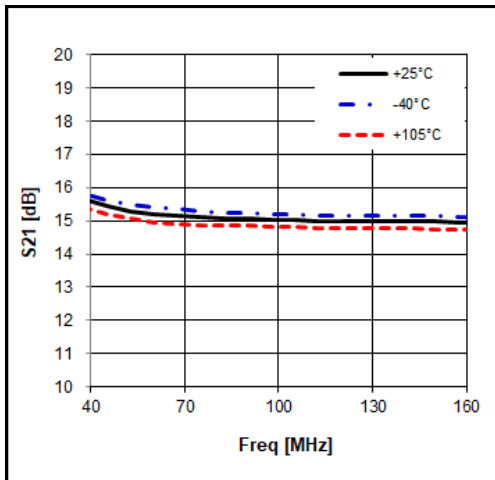
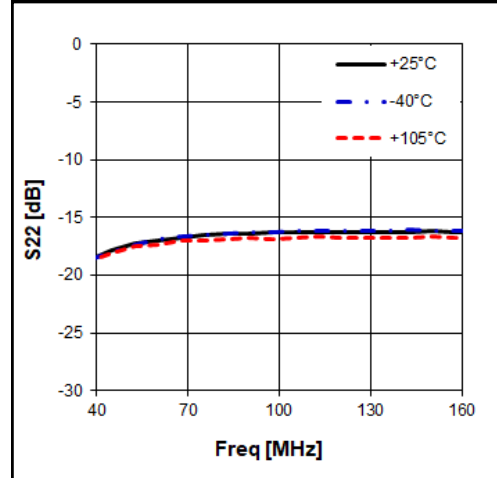
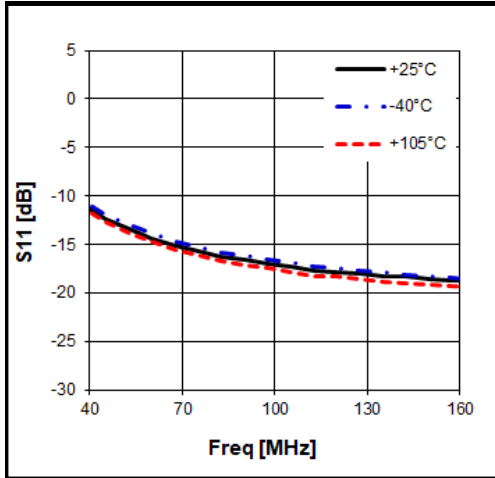

Application Circuit: 900 MHz

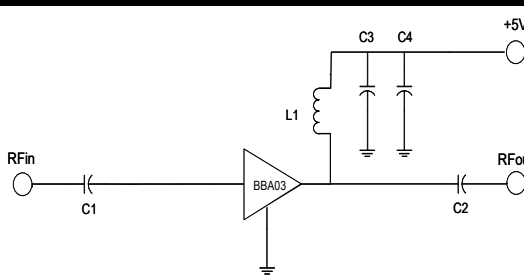
Schematic Diagram	BOM		Size
	C1	100pF	0603
	C2	100pF	0603
	C3	100pF	0603
	C4	1uF	0603
	L1	22nH	0603

Typical Performance (Vd=5V, Id=100mA, T=25°C)

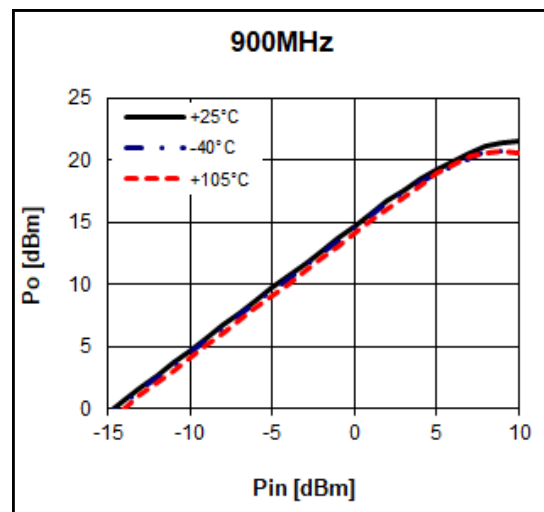
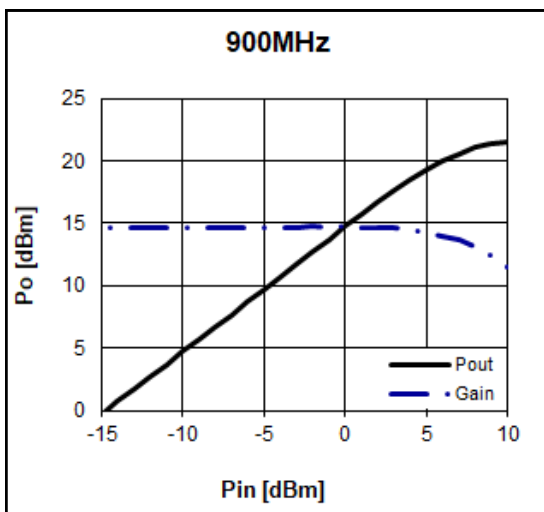

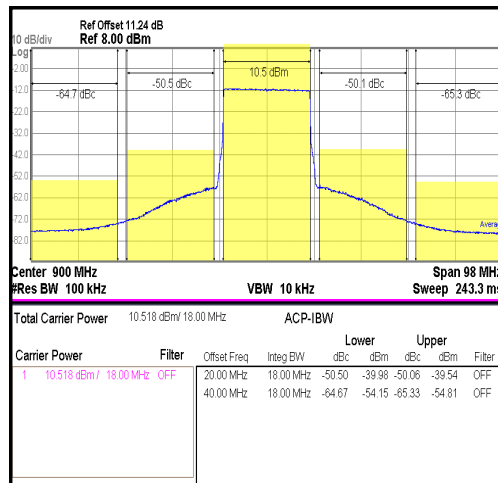
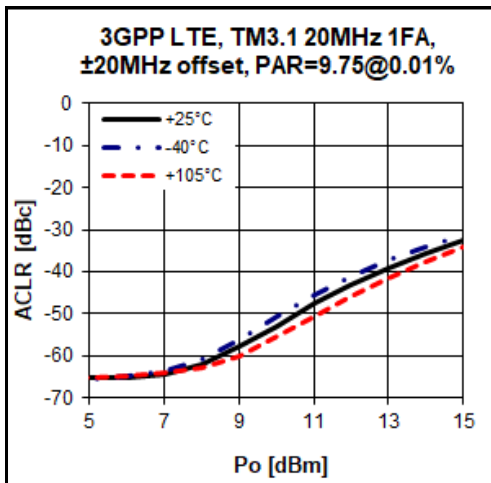
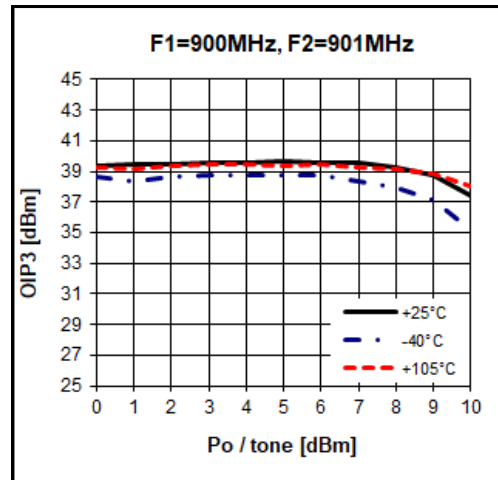
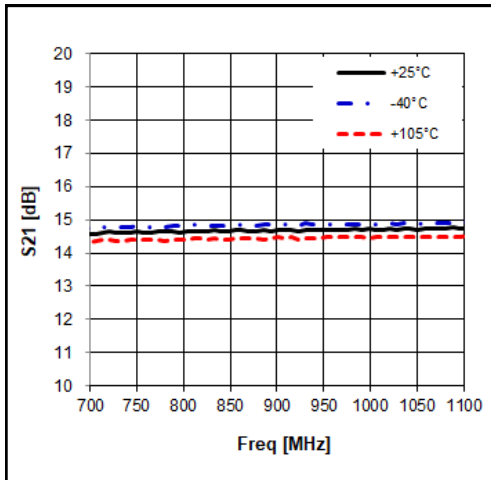
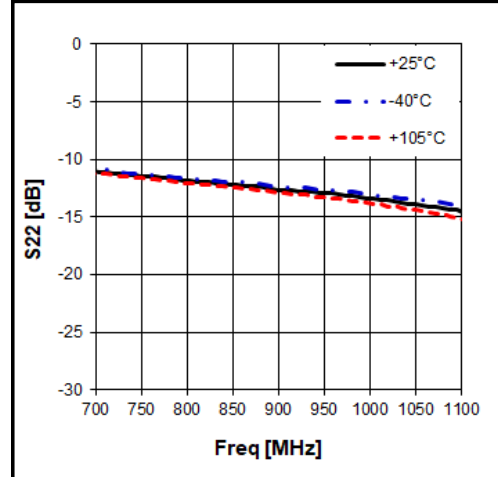
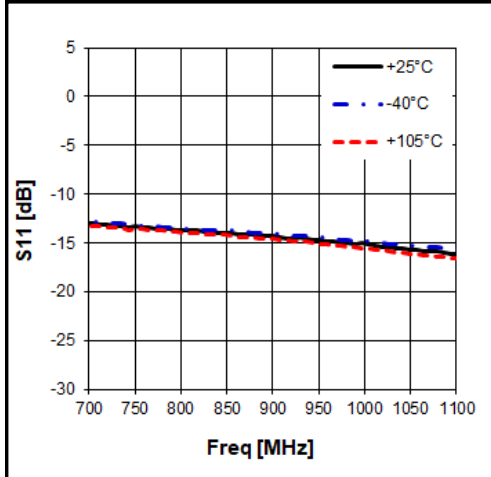

Application Circuit: 1800 MHz

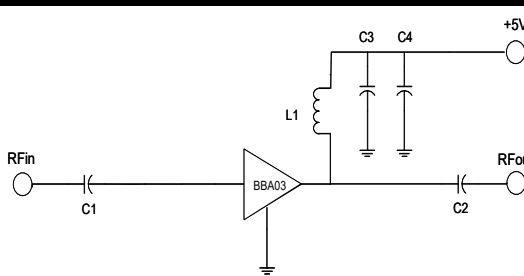
Schematic Diagram		BOM	Size	
		C1	22pF	0603
		C2	22pF	0603
		C3	100pF	0603
		C4	1uF	0603
		L1	5.6nH	0603

Typical Performance (Vd=5V, Id=100mA, T=25°C)

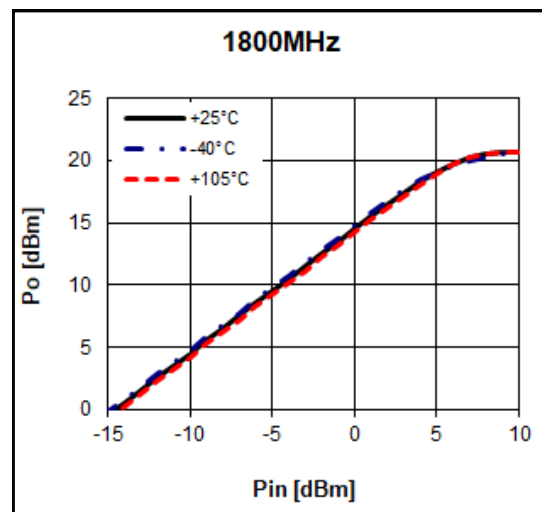
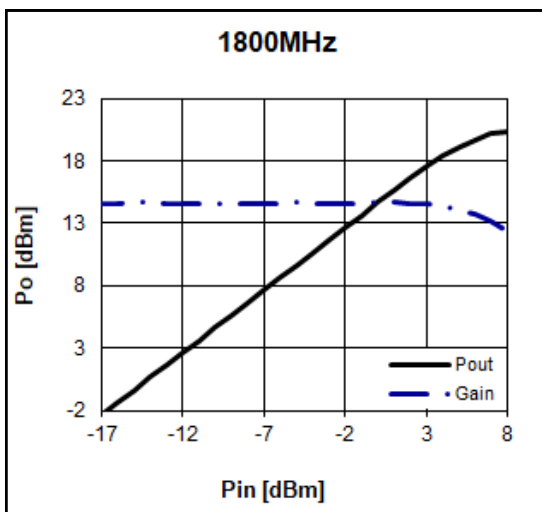

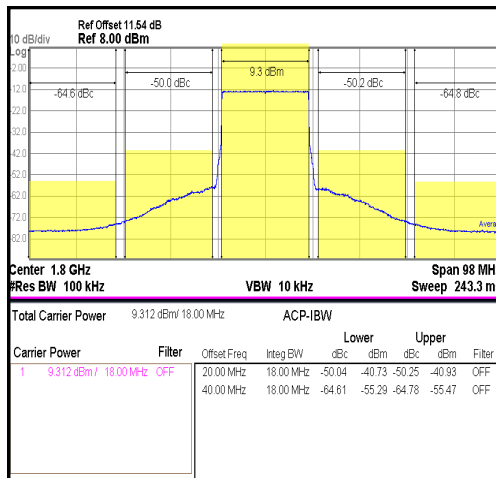
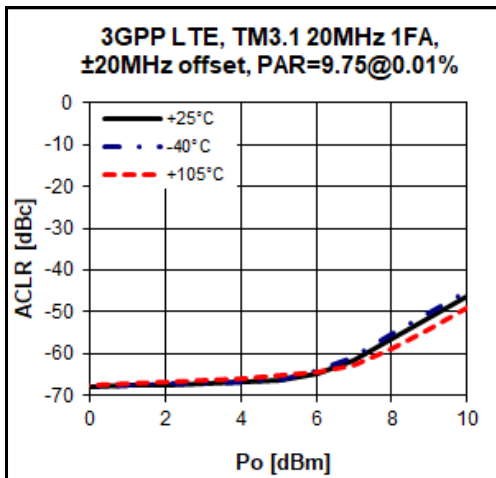
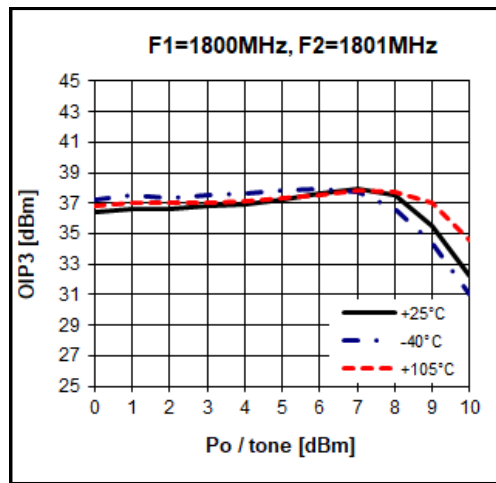
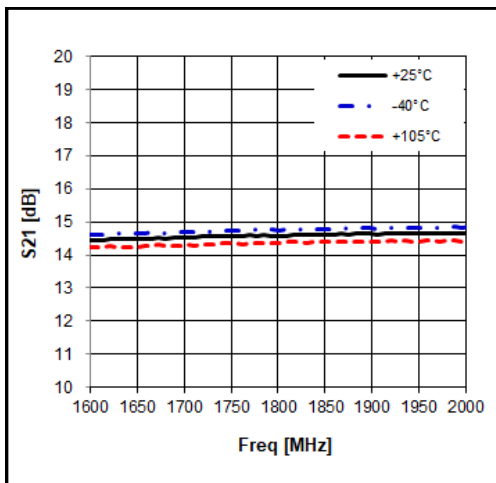
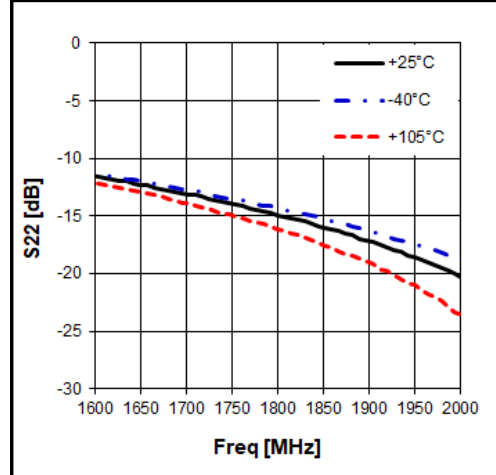
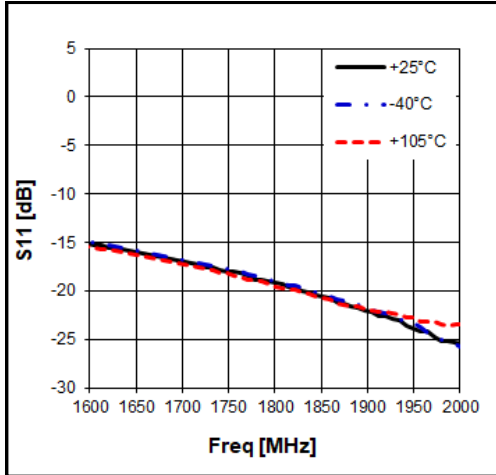
30-6000 MHz Flat Gain BroadBand AMP

Application Circuit: 2140 MHz

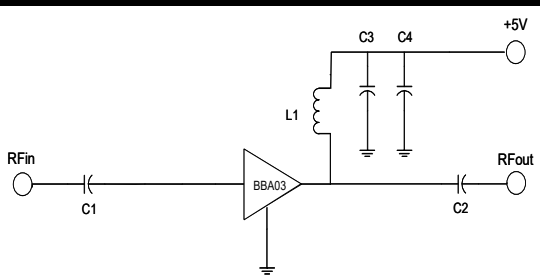
Schematic Diagram	BOM		Size
	C1	22pF	0603
	C2	22pF	0603
	C3	100pF	0603
	C4	1uF	0603
	L1	5.6nH	0603

Typical Performance (Vd=5V, Id=100mA, T=25°C)

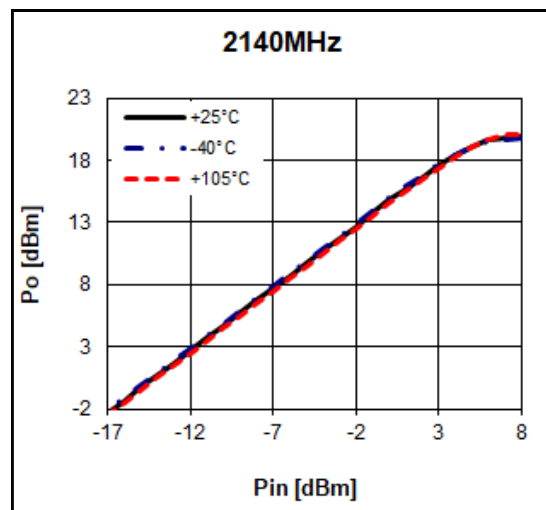
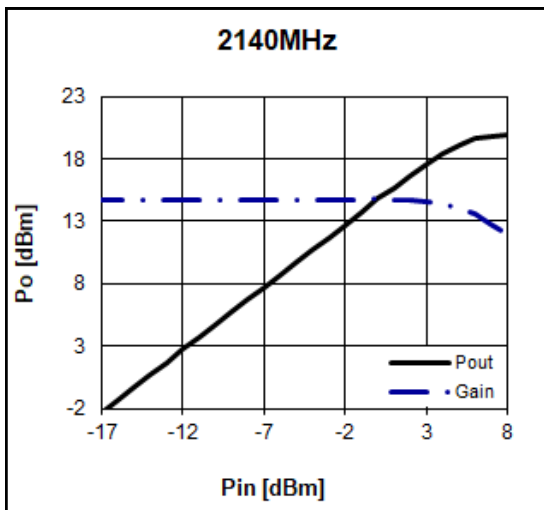

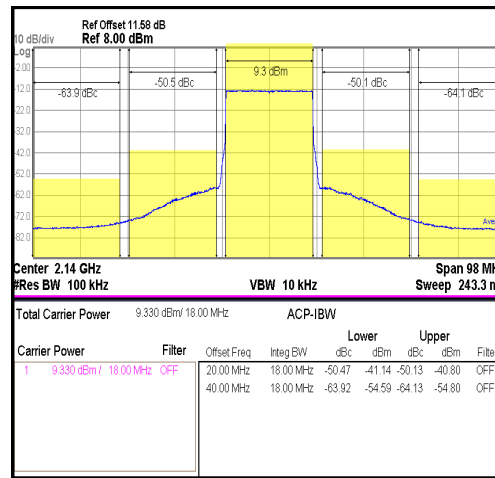
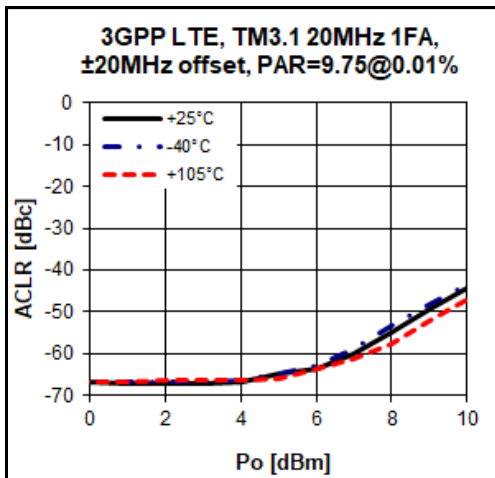
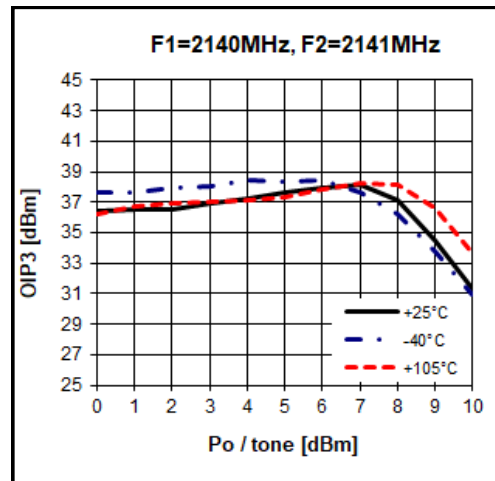
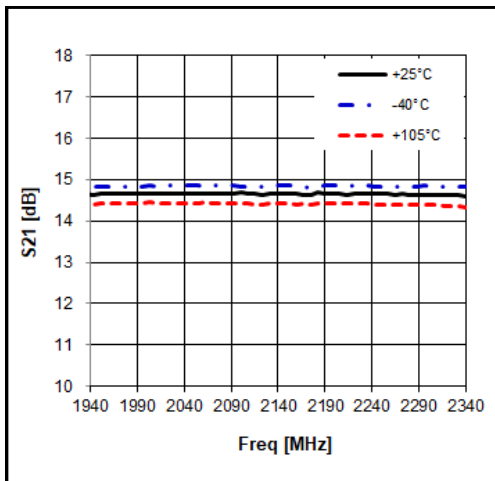
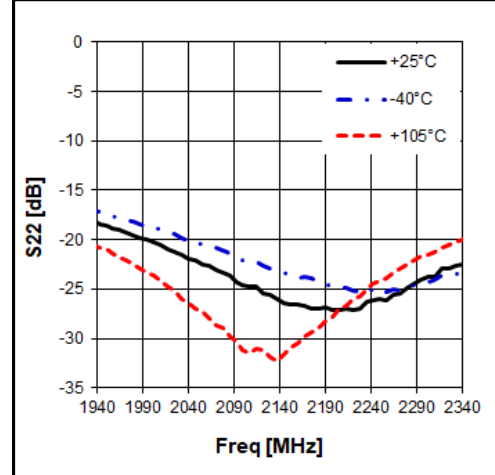
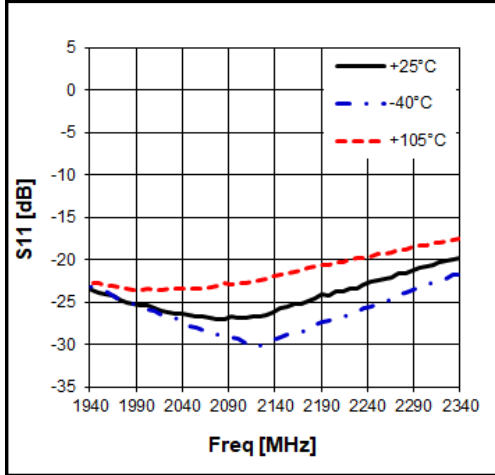

Application Circuit: 2650 MHz

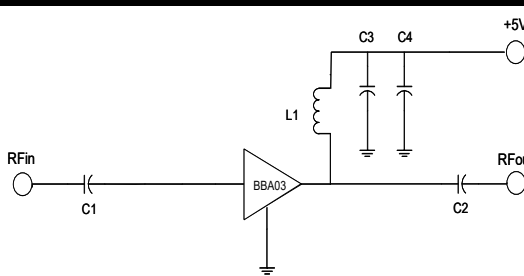
Schematic Diagram	BOM		Size
	C1	22pF	0603
	C2	22pF	0603
	C3	100pF	0603
	C4	1uF	0603
	L1	5.6nH	0603

Typical Performance (Vd=5V, Id=100mA, T=25°C)

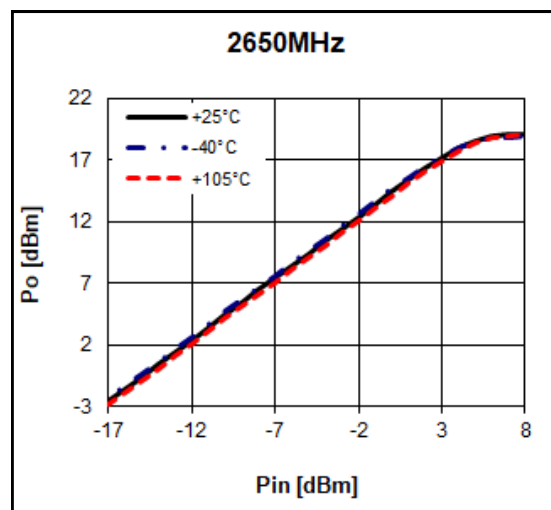
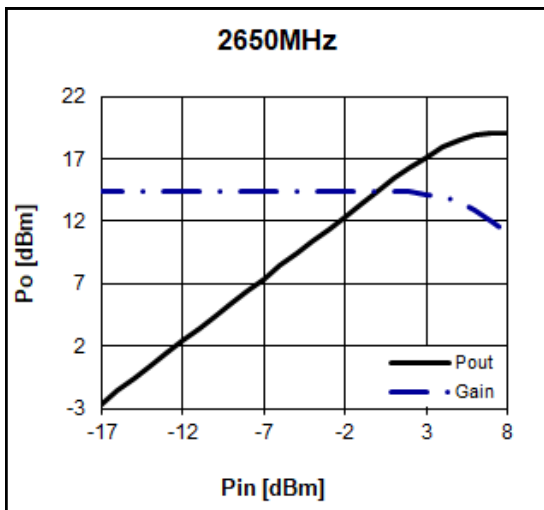

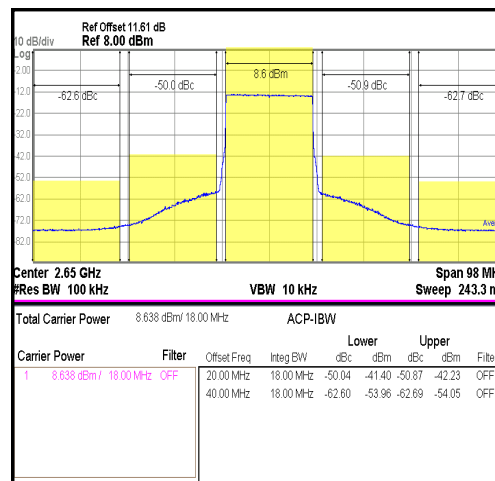
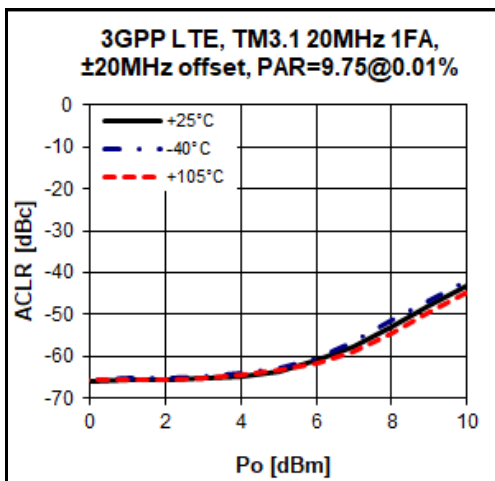
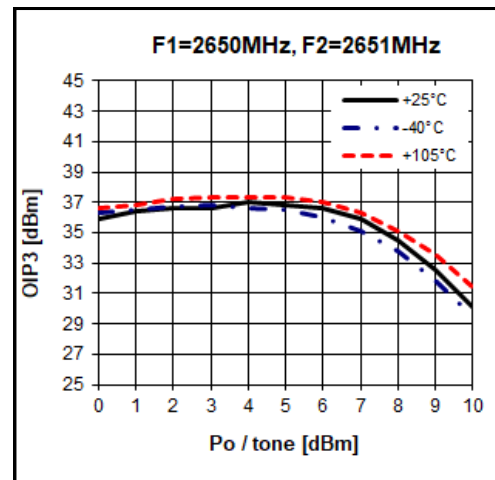
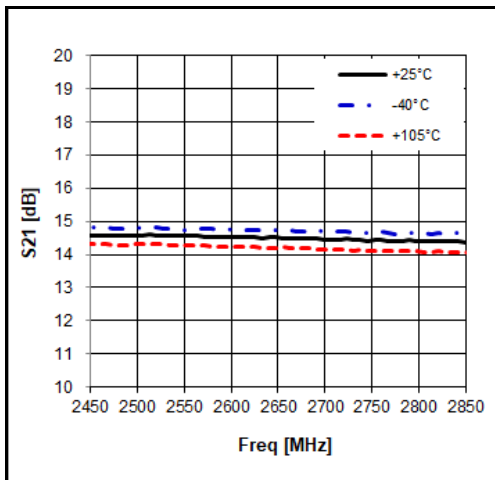
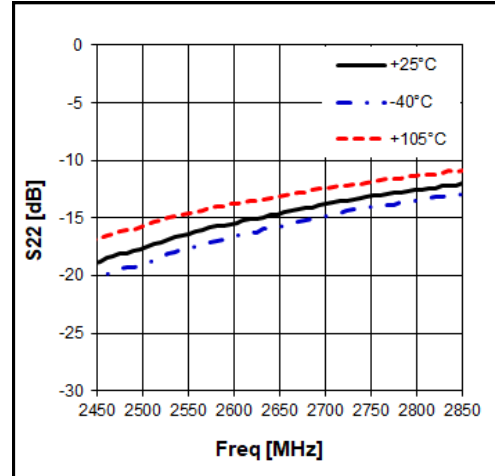
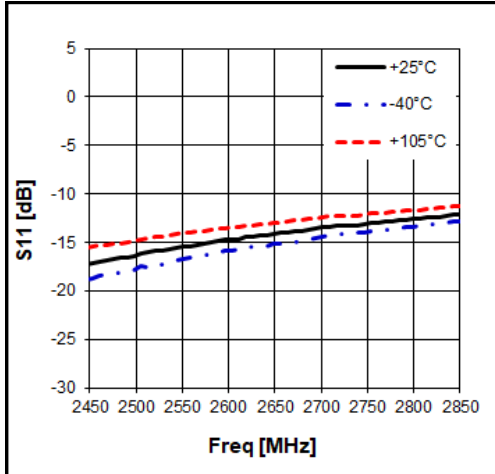

Application Circuit: 3500 MHz

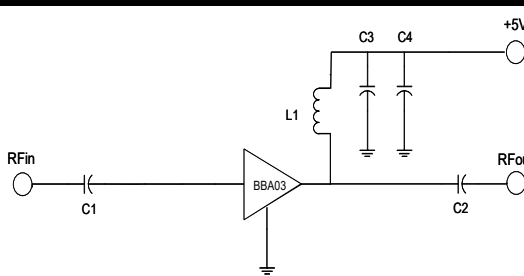
Schematic Diagram	BOM		Size
	C1	22pF	0603
	C2	22pF	0603
	C3	100pF	0603
	C4	1uF	0603
	L1	5.6nH	0603

Typical Performance (Vd=5V, Id=100mA, T=25°C)

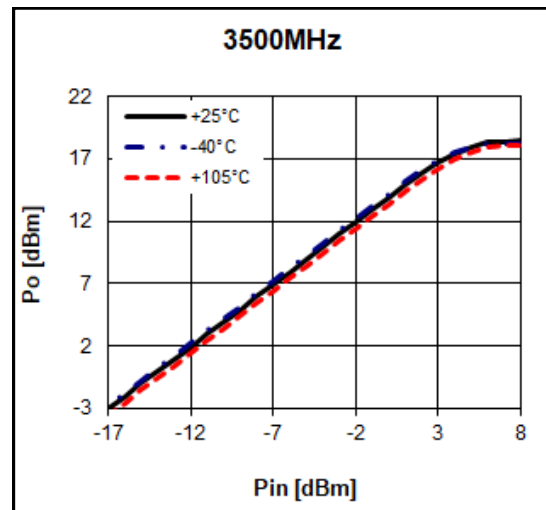
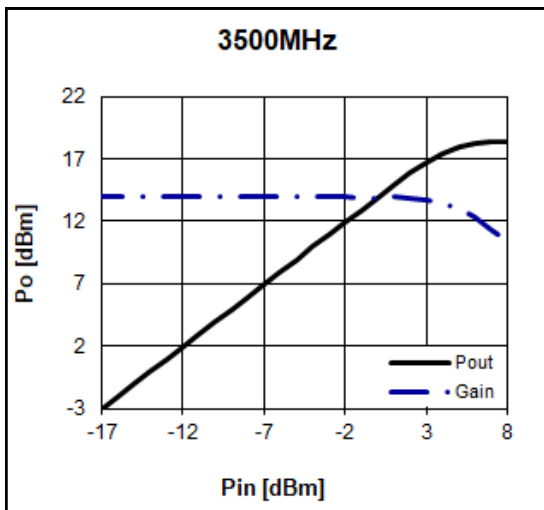

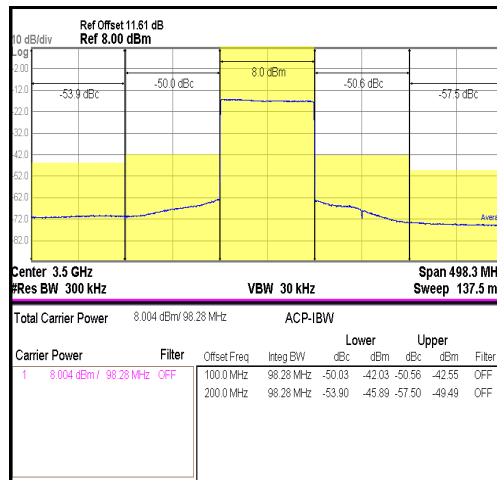
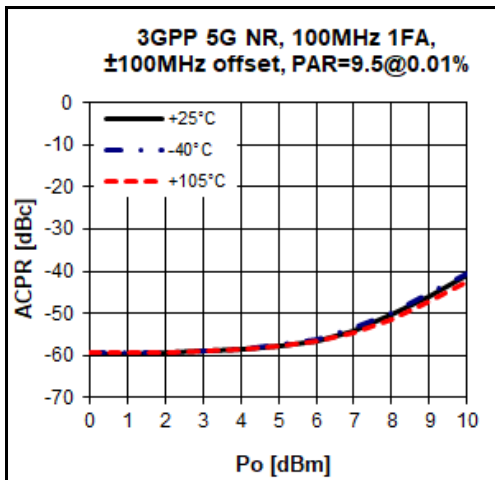
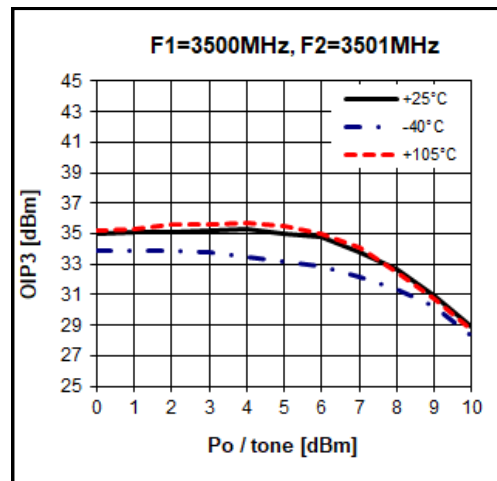
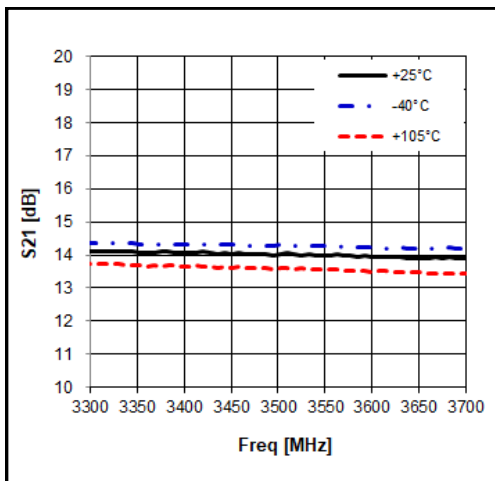
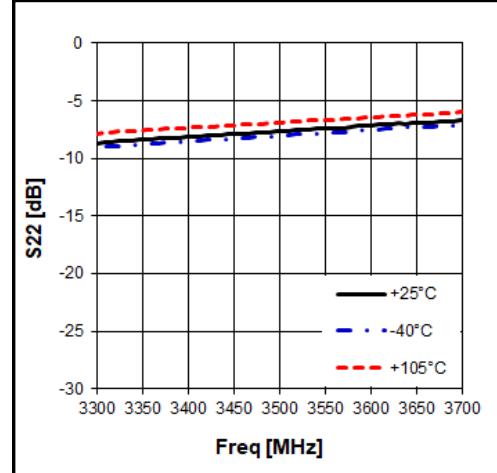
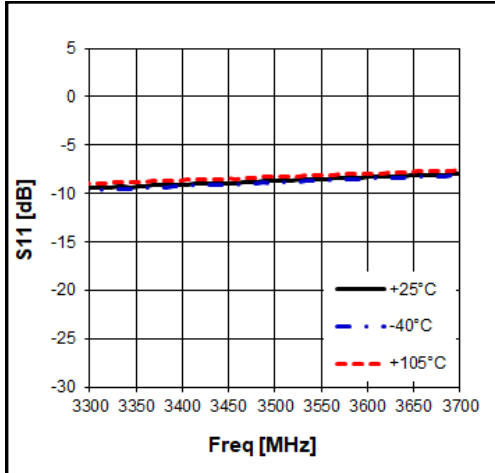

Package Outline Dimension

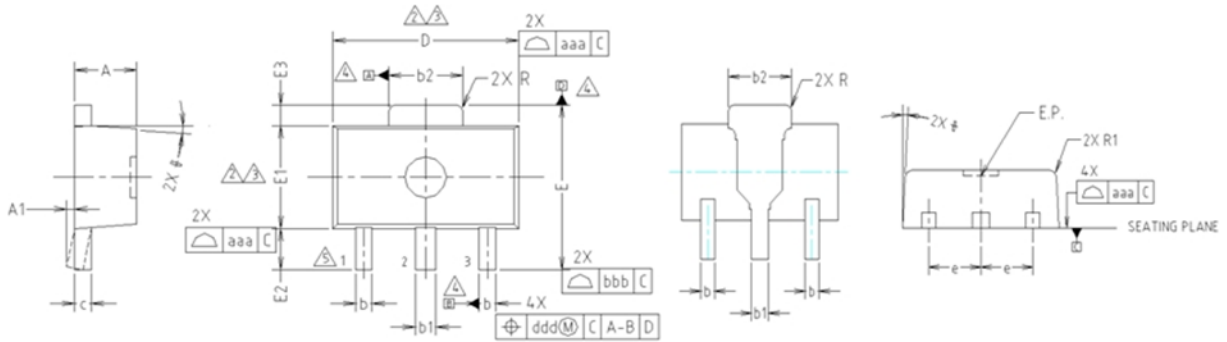

- NOTE:**
 1. DIMENSIONS IN MILLIMETERS.
- ⚠ DIMENSION D DOES NOT INCLUDE MOLD FLASH, PROTRUSIONS OR GATE BURRS. MOLD FLASH, PROTRUSIONS OR GATE BURRS SHALL NOT EXCEED 0.5mm PER END. DIMENSION E1 DOES NOT INCLUDE INTERLEAD FLASH OR PROTRUSION. INTERLEAD FLASH OR PROTRUSION SHALL NOT EXCEED 0.5mm PER SIDE.
 - ⚠ DIMENSIONS D AND E1 ARE DETERMINED AT THE OUTMOST EXTREMES OF THE PLASTIC BODY EXCLUSIVE OF MOLD FLASH, TIE BAR BURRS, GATE BURRS AND INTERLEAD FLASH, BUT INCLUDING ANY MISMATCH BETWEEN THE TOP AND BOTTOM OF THE PLASTIC BODY.
 - ⚠ DATUMS A, B AND D TO BE DETERMINED 0.18mm FROM THE LEAD TIP.
 - ⚠ TERMINAL NUMBERS ARE SHOWN FOR REFERENCE ONLY.

SYMBOL	MILLIMETERS			NOTE
	MINIMUM	NOMINAL	MAXIMUM	
A	1.40	1.50	1.60	
A1	0.00	—	0.10	
b	0.38	0.42	0.48	
b1	0.48	0.52	0.58	
b2	1.79	1.82	1.87	
c	0.40	0.42	0.46	
D	4.40	4.50	4.70	2,3
E	3.70	4.00	4.30	
E1	2.40	2.50	2.70	2,3
E2	0.80	1.00	1.20	
E3	0.40	0.50	0.60	
e	1.50 TYP.			
φ	4° TYP.			
R	0.15 TYP.			
R1	—	—	0.20	
SYMBOL	TOLERANCES OF FORM AND POSITION		NOTE	
aaa	0.15			
bbb	0.20			
ccc	0.10			
ddd	0.10			

Suggested PCB Land Pattern and PAD Layout

PCB Land Pattern

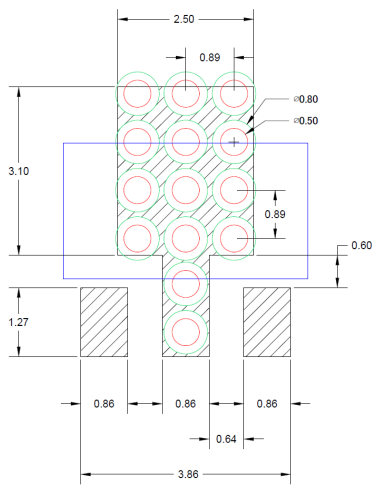

PCB Mounting

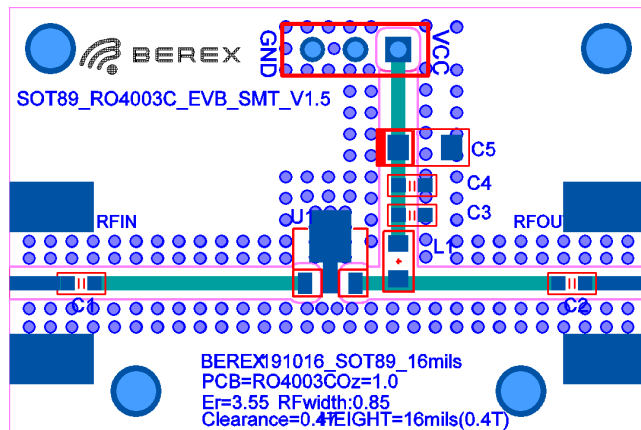

Note : All dimension _ millimeters

PCB lay out _ on BeRex website

Package Marking

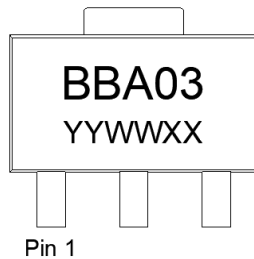

YY = Year, WW = Working Week,
XX = Wafer No.

Tape & Reel

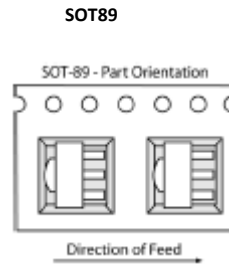

Packaging information:

Tape Width (mm): 12
Reel Size (inches): 7
Device Cavity Pitch (mm): 8
Devices Per Reel: 1000

Lead plating finish

100% Tin Matte finish

(All BeRex products undergoes a 1 hour, 150 degree C, Anneal bake to eliminate thin whisker growth concerns.)

MSL / ESD Rating

ESD Rating:	Class 1B
Value:	Passes <1000V
Test:	Human Body Model (HBM)
Standard:	JEDEC Standard JS-001-2017
MSL Rating:	Level 1 at +260°C convection reflow
Standard:	JEDEC Standard J-STD-020



Proper ESD procedures should be followed when handling this device.

RoHS Compliance

This part is compliant with Restrictions on the Use of Certain Hazardous Substances in Electrical and Electronic Equipment (RoHS) Directive 2011/65/EU as amended by Directive 2015/863/EU.

This product also is compliant with a concentration of the Substances of Very High Concern (SVHC) candidate list which are contained in a quantity of less than 0.1%(w/w) in each components of a product and/or its packaging placed on the European Community market by the BeRex and Suppliers.

NATO CAGE code:

2	N	9	6	F
---	---	---	---	---