

MATERIAL

Glass-fibre reinforced polyamide based (PA) technopolymer, black colour, matte finish.

STANDARD EXECUTIONS

- **BAS3-A:** zinc-plated steel M10 screws, nuts and washers.
- **BAS3-SST:** AISI 304 stainless steel M10 screws, nuts and washers.

ASSEMBLY ON LEVELLING ELEMENTS

The three bearings of the base are supplied with brass bosses, threaded pass-through hole for the assembly of the stem of the levelling element series LS.A (see page 1224), LV.A (see page 1238), LV.F (see page 1258).

FEATURES

The absence of cavities and the slightly round shapes offer modern and elegant aesthetics and guarantee the easy cleaning. Maximum tightening torque for screw assembly 35 Nm.

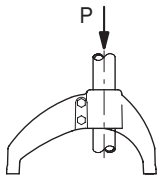

Retention force
P = 2000 N

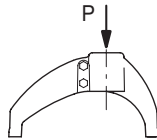

Max. static load
P = 9800 N

Values obtained with tightening torque 35 Nm

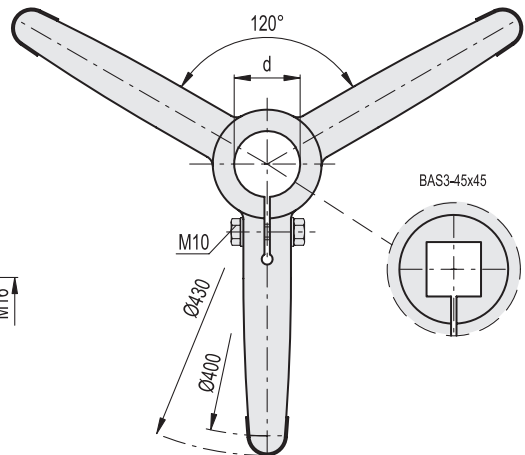
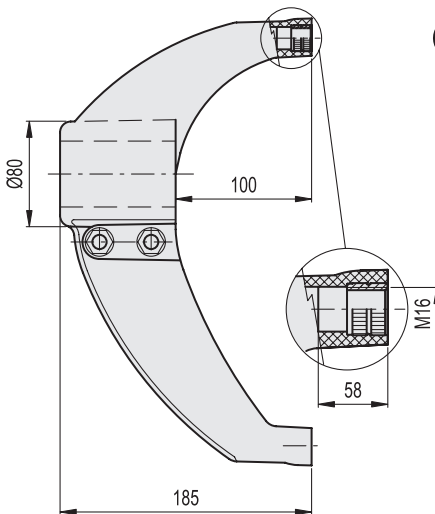

Conversion Table	
1 mm = 0.039 inch	
mm	inch
42.4	1.67
45	1.77
48.3	1.90
50.8	2.00
60.3	2.37

BAS3-A

METRIC

BAS3-SST

METRIC

INOX STAINLESS STEEL

Code	Description	d Tube (mm)	d Tube (GAS)	d Tube (inch)	⚖	Code	Description
419592	BAS3-42-A	42.4	1"1/4	-	800	419593	BAS3-42-SST
419590	BAS3-48-A	48.3	1"1/2	-	790	419591	BAS3-48-SST
419594	BAS3-50-A	50.8	-	2"	780	419595	BAS3-50-SST
419588	BAS3-60-A	60.3	2"	-	770	419589	BAS3-60-SST
419752	BAS3-45x45-A	45	-	-	795	419753	BAS3-45x45-SST



Leveling elements and supports