

# APPROVAL SHEET

**WW25D, WW12D, WW08D, WW06D, WW04D**

**±0.5%, ±1%, ±5%**

**Metal Foil Low Ohm Power Chip Resistor**

**Size 2512, 1206, 0805, 0603, 0402**

## **Sensing Type**

**Anti-Sulfur ASTM B-809 105C 1000hrs**

Customer : \_\_\_\_\_

Approval No : \_\_\_\_\_

Issue Date : \_\_\_\_\_

Customer Approval :

\*Contents in this sheet are subject to change without prior notice.

## FEATURE

1. Ultra low and stable TCR performance
2. High power rating and compact size
3. High reliability and stability
4. Reduced size of final equipment
5. RoHS exemption free & Lead free
6. ASTM B-809 105C 1000hrs compliant

## APPLICATION

- Power supply
- PDA
- Digital meter
- Computer
- Automotives
- Battery charger
- DC-DC power converter

## DESCRIPTION

The resistors are constructed in a high grade low resistive metal foil which adhere on top of ceramic substrate body. The resistive layer is covered with a protective coat and printed a resistance marking code over it. Finally, the two external end terminations are added. For ease of soldering the outer layer of these end terminations is a Lead free terminations.

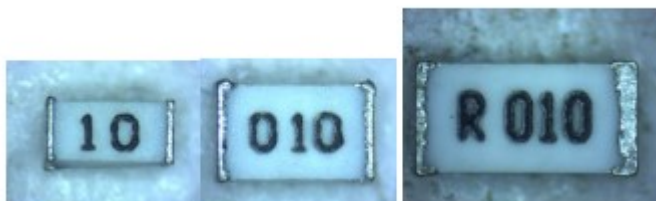

Fig 1. Construction of 0603/0805/1206

**QUICK REFERENCE DATA**

Item	General Specification				
Series No.	WW25D	WW12D	WW08D	WW06D	WW04D
Size code	2512 (6432)	1206 (3216)	0805 (2012)	0603 (1608)	0402 (1005)
Resistance Tolerance	±5% , ±1%, ±0.5% (only for TC50)				
Resistance Range	2-450mΩ, 700 mΩ	3-700mΩ	3-500mΩ	5-75mΩ	5 - 25 mΩ
TCR (ppm/°C) +25 ~ +125°C	2~9mΩ: ±100 10~700mΩ: ±50	3~9mΩ: ±100 10~700mΩ: ±50	3~9mΩ: ±100 10~500mΩ: ±50	5~9mΩ: ±100 10~75mΩ: ±50	5~25mΩ: ±100
Max. power at T <sub>amb</sub> =70°C	2W	1W	3/4W	1/2W	1/3W
Operation Temperature	-55 ~ +155°C				

Note : Max. Operation Current : So called RCWC (Rated Continuous Working Current) is determined by

$$RCWC = \sqrt{\text{Rated Power} / \text{Resistance Value}} \text{ listed above.}$$

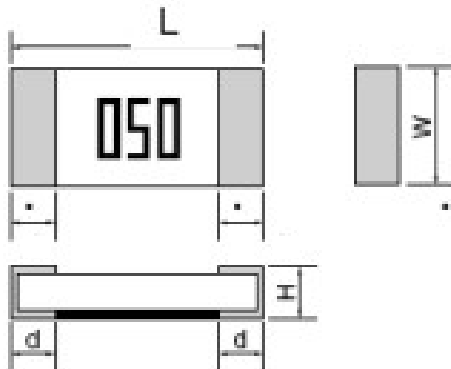
**MECHANICAL DATA**

Type	Size (inch)	R-value	L (mm)	W (mm)	H (mm)	d (mm)
WW25D	2512	R002	6.4±0.30	3.2±0.30	0.65±0.20	2.8±0.30
		R003	6.4±0.30	3.2±0.30	0.65±0.20	2.6±0.30
		R004-R009	6.4±0.30	3.2±0.30	0.65±0.20	1.05±0.30
		R010-R049	6.4±0.30	3.2±0.30	0.65±0.20	1.05±0.30
		R050-R700	6.4±0.30	3.2±0.30	0.65±0.20	1.05±0.30
WW12D	1206	R003	3.3±0.20	1.7±0.20	0.65±0.20	1.20±0.30
		R004-R008	3.3±0.20	1.7±0.20	0.65±0.20	0.68±0.30
		R009-R049	3.3±0.20	1.7±0.20	0.65±0.20	0.68±0.30
		R050-R700	3.3±0.20	1.7±0.20	0.65±0.20	0.68±0.30
WW08D	0805	R003	2.10±0.20	1.35±0.20	0.65±0.20	0.65±0.20
		R004	2.10±0.20	1.35±0.20	0.65±0.20	0.50±0.20

		R005-R007	2.10±0.20	1.35±0.20	0.65±0.20	0.50±0.20
		R008-R049	2.10±0.20	1.35±0.20	0.65±0.20	0.50±0.20
		R050-R500	2.10±0.20	1.35±0.20	0.65±0.20	0.5±0.20
WW06D	0603	R005	1.7±0.20	0.9±0.20	0.65±0.20	0.50±0.20
		R006-R009	1.7±0.20	0.9±0.20	0.65±0.20	0.40±0.20
		R010-R049	1.7±0.20	0.9±0.20	0.65±0.20	0.40±0.20
		R050-R100	1.7±0.20	0.9±0.20	0.65±0.20	0.40±0.20
WW04D	0402	R005-R025	1.0±0.10	0.55±0.10	0.30±0.05	0.23±0.10

## RECOMMENDED SOLDER LAND PATTERN

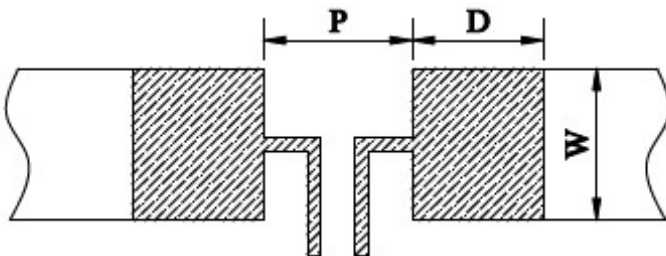

Type	R-value	P (mm)	W (mm)	D (mm)
WW25D	R002	0.60	3.57	4.35
	R003	0.90	3.57	4.20
	R004-R009	3.10	3.57	3.10
	R010-R700	3.10	3.57	3.10
WW12D	R003	0.60	1.84	2.10
	R004-R008	1.20	1.84	1.80
	R009-R700	1.20	1.84	1.80
WW08D	R003	0.50	1.44	1.55
	R004-R007	0.80	1.44	1.40
	R008-R500	0.80	1.44	1.40
WW06D	R005	0.50	0.92	1.35
	R006-R009	0.60	0.92	1.30
	R010-R075	0.60	0.92	1.30
WW04D	R005-R025	0.40	0.60	0.60

## MARKING

Each resistor is marked with a four-digit code on 2512/1206 & three-digit code on 0805 & two-digit on 0603 protective coating to designate the nominal resistance value.0402 has n marking.

Example:

$$\begin{aligned} R020 &= 0.02\Omega \text{ ( WW25D/WW12D )} \\ 020 &= 0.02\Omega \text{ ( WW08D )} \\ 20 &= 0.02 \Omega \text{ ( WW06D )} \end{aligned}$$

## FUNCTIONAL DESCRIPTION

### Derating curve

The power that the resistor can dissipate depends on the operating temperature; see Fig.2

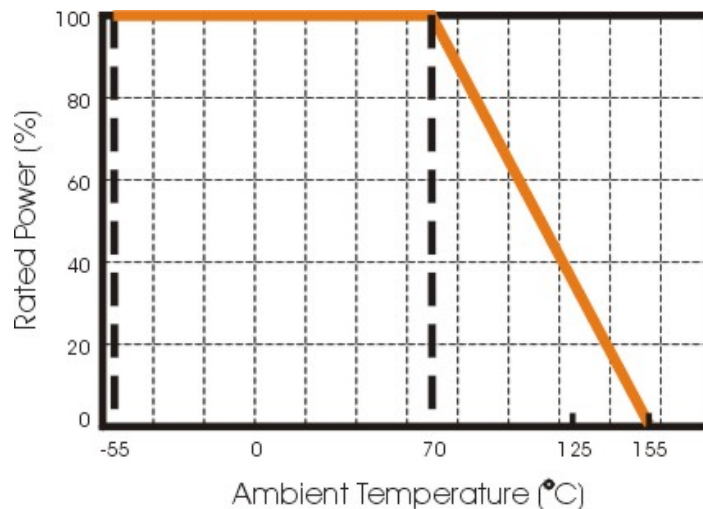

Fig.2 Maximum dissipation in percentage of rated power  
As a function of the ambient temperature

## STORAGE CONDITIONS

Under airtight in temperature  $+10^{\circ}\text{C} \sim 40^{\circ}\text{C}$  、 relative humidity  $\leq 75\%$  can store 2 years.

Without dew in temperature  $+10^{\circ}\text{C} \sim 60^{\circ}\text{C}$  、 relative humidity be 95% maximum value for 30days.

## SOLDERING CONDITIONS

The robust construction of chip resistors allows them to be completely immersed in a solder bath of  $260^{\circ}\text{C}$  for max.10 seconds. Therefore, it is possible to mount Surface Mount Resistors on one side of a PCB and other discrete components on the reverse (mixed PCBs).

Typical examples of soldering processes that provide reliable joints without any damage are given in Fig3 as below.

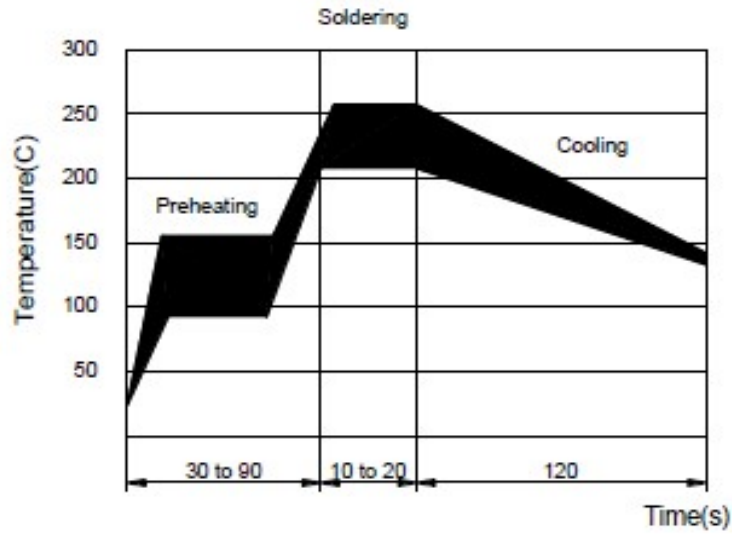

Fig 3. Infrared soldering profile for Chip Resistors

**CATALOGUE NUMBERS**

The resistors have a catalogue number starting with .

WW12	D	R020	F	T	L
<b>Size code</b>	<b>Type code</b>	<b>Resistance code</b>	<b>Tolerance</b>	<b>Packaging code</b>	<b>Termination code</b>
WW25 : 2512 WW20 : 2010 WW12 : 1206 WW08 : 0805 WW06 : 0603 WW04 : 0402	<b>D : Metal foil</b>	R is first digit followed by 3 significant digits. 0.020Ω = R020 0.040Ω = R040	J : ±5% F : ±1% D : ±0.5%	T : 7" reeled in tape	L = Sn base (lead free)

0402 Reeled tape packaging : 8mm width paper taping 10,000pcs per reel.

1206/ 0805/ 0603 Reeled tape packaging : 8mm width paper taping 5,000pcs per reel.

2512 Reeled tape packaging : 8mm width PC taping 4,000pcs per reel.

**TEST & REQUIREMENTS**

測試方法 Parameter	條件 Conditions	允收標準 Requirements
瞬間過載測試 / Short Time Over Load	$P = 2.5P_r$ ; $T = 25 \pm 2^\circ\text{C}$ , $t = 5\text{sec}$ .	$\pm(1.0\% + 0.5\text{m}\Omega)$ IEC60115-1 4.13
高溫測試 / High Temp. Exposure	$T = +170 \pm 2^\circ\text{C}$ ; $t = 1000\text{h}$	$\pm(1.0\% + 0.5\text{m}\Omega)$ IEC60115-1 4.25
低溫測試 / Low Temp. Storage	$T = -55 \pm 2^\circ\text{C}$ ; $t = 1000\text{h}$	$\pm(1.0\% + 0.5\text{m}\Omega)$ IEC60115-1 4.25
濕度負載壽命測試 / Moisture Load Life ( $60^\circ\text{C}$ 、 $95\%\text{RH}$ )	$V_{\text{test}} = V_{\text{max}}$ ; $T = 60 \pm 2^\circ\text{C}$ ; $\text{RH} = 95\%$ ; $t = 90\text{min ON}$ , $30\text{min OFF}$ , $1000\text{h}$	$\pm(2.0\% + 0.5\text{m}\Omega)$ IEC60115-1 4.25
冷熱衝擊測試 / Thermal Shock	$[-55^\circ\text{C } 30\text{min.} \rightarrow \text{R.T. } 3\text{min.} \rightarrow +155^\circ\text{C } 30\text{min.}$ $\rightarrow \text{R.T. } 3\text{min.}]$ , 100 個連續循環 / 100Cycles	$\pm(1.0\% + 0.5\text{m}\Omega)$ IEC60115-1 4.19
在 $70^\circ\text{C}$ 下負載壽命測試 / Load Life at $70^\circ\text{C}$	$V_{\text{test}} = V_{\text{max}}$ ; $T = 70 \pm 2^\circ\text{C}$ ; $t = 90\text{min ON}$ , $30\text{min OFF}$ , $1000\text{h}$	$\pm(2\% + 0.5\text{m}\Omega)$ IEC60115-1 4.25
可焊性測試 / Solderability	浸入錫爐 / Dip into solder at $T = 245 \pm 5^\circ\text{C}$ , $t = 3 \pm 0.5\text{sec}$ .	錫涵蓋面積 / The covered area $> 95\%$ IEC60115-1 4.17
抗焊熱性測試 / Resistance to Solder Heat	經熱風式迴焊爐 / Through Reflow $T = 275 \pm 5^\circ\text{C}$ , $t = 20 \pm 1\text{sec}$ .	$\pm(1.0\% + 0.5\text{m}\Omega)$ IEC60115-1 4.18
機械衝擊測試 / Mechanical Shock	加速度 $a = 100\text{G}$ , 振幅時間 $t = 11\text{ms}$ , 5 個衝擊 $a = 100\text{G}$ , $t = 11\text{ms}$ , 5 times shock	$\pm(1.0\% + 0.5\text{m}\Omega)$ IEC60115-1 4.21
基板彎曲測試 / Substrate Bending	兩支撐點間距 / Span between fulcrums : $90\text{mm}$ ; 振幅 / Bend Width : $2\text{mm}$ ; 測試板 / Test board : 玻璃纖維板 / Glass-Epoxy Board ; 厚度 / Thickness = $1.6\text{mm}$	$\pm(1.0\% + 0.5\text{m}\Omega)$ IEC60115-1 4.33

**PACKAGING**

Tape Specifications (unit :mm)

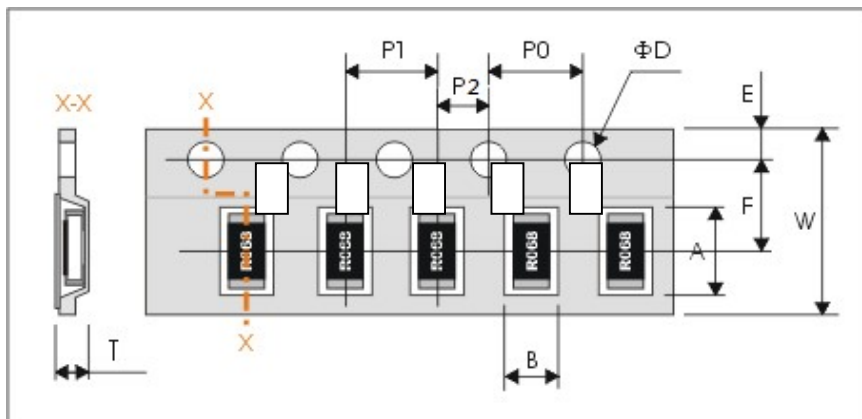

Symbol	A	B	W	F	E
WW25D	6.75±0.20	3.40±0.20	8.00±0.20	3.50±0.05	1.75±0.10
WW12D	3.65±0.20	2.05±0.20	8.00±0.20	3.50±0.05	1.75±0.10
WW08D	2.38±0.20	1.68±0.20	8.00±0.20	3.50±0.05	1.75±0.10
WW06D	1.98±0.20	1.18±0.20	8.00±0.20	3.50±0.05	1.75±0.10
WW04D	1.25±0.20	0.75±0.20	8.00±0.20	3.50±0.05	1.75±0.10
Symbol	P1	P0	P2	ΦD	T
WW25D	4.00±0.10	4.00±0.10	P2=1/2 P0	Φ 1.5±0.10	1.00±0.20
WW12D	4.00±0.10				0.87±0.20
WW08D	4.00±0.10				0.87±0.20
WW06D	4.00±0.10				0.65±0.20
WW04D	2.00±0.10				0.50±0.10

**Reel Dimensions**

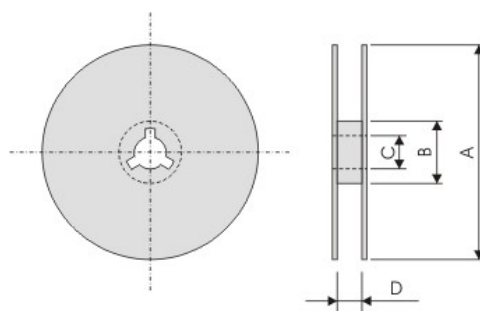

Symbol	A	B	C	D
(unit : mm)	Φ180.0 -1.5	Φ60.0±1.0	13.0±0.2	9.0 +1.0

**Taping Quantity**

- 1206/0805/0603 chip resistors 5,000 pcs per reel.
- 2512 chip resistors 4,000 pcs per reel.
- 0402 chip resistors 10,000 pcs per reel.