

Product Document

AS3953

14443 High Speed Passive Tag Interface

1 General Description

The AS3953 NFC interface IC (NFiC) delivers low cost, ultra low power NFC forum functionality to multiple different applications. The AS3953 is a analog front-end with integrated 14443A data framing and SPI interface. It is designed to create a fast data link between an ISO 14443A reader device (PCD) and a microcontroller. The AS3953 is *Passively powered* meaning that it can be supplied from the PCD magnetic field, eliminating the need of a continual external supply. This makes the AS3953 perfect for wireless communication to a low-power battery powered device.

The AS3953 is used with an appropriate antenna coil connected to the terminals LC1 and LC2, and behaves as a normal passive ISO 14443A tag (PICC). After the anti-collision protocol is passed, the PCD sends a *Wake-up* command, which wakes up the microcontroller by sending an interrupt. From this point onwards, the AS3953 serves as a data link between the microcontroller and the PCD. AS3953 can also operate as NFCIP-1 target at 106 kb/s.

The AS3953 includes an onboard EEPROM that can be accessed either from the PCD or from the microcontroller via the SPI interface. This built-in flexibility makes it ideal for two types of applications:

- Where personalization data is programmed by the PCD (even in case the SPI side is not powered) and it is later read by microcontroller through SPI interface.
- Where log data is stored periodically by the microcontroller and can then be read by the PCD even when the microcontroller is not powered.

A regulated power supply voltage extracted from the PCD field is also available on a pin and can be used as power supply for external circuitry. For example, an external microcontroller and a sensor could be powered from the PCD field combined with pass through data rates up to 848Kbps, which means the AS3953 is ideal for contactless passive programming of MCU systems. The AS3953 can also operate as a stand-alone ISO 14443A tag.

The AS3953 supports ISO 14443A up to Level-4, meaning a contactless smart card or an NFC forum compatible tag (Tag Type 4) can be built. Having a NFC Forum compatible tag interface allows the AS3953 to be used in an application where a standard NFC enabled phone is used as a PCD.

2 Key Features

- ISO 14443A compliant to Level-4
- NFCIP-1 target at 106 kb/s
- 1k bit EEPROM (928 bits of user memory)
- Configurable wake-up interrupt (after tag is selected or using proprietary command)
- Powered from external magnetic field with the possibility to draw up to 5mA
- 7 byte UID
- User configurable regulated voltage extracted from external magnetic field
- Bit rates from 106 Kbps till 848 Kbps
- Integrated resonant capacitor
- Integrated buffer capacitor
- 4-wire Serial Peripheral Interface (SPI) with 32 byte FIFO
- Wide SPI power supply range (1.65V to 3.6V)
- Wide temperature range: -40°C to 85°C
- Available as die, WLCS or in 10 (3x3mm) package

3 Applications

The device is ideal for applications like Passive wake-up, Multipurpose HF interface to a controller, Low power or passive programming, Ultra Low Power Data Logger, RFID Programmable configuration EEPROM, ISO 14443A smart card, NFC Forum Tag Type 4, and Bluetooth and Wi-Fi pairing.

Figure 1. AS3953 Block Diagram

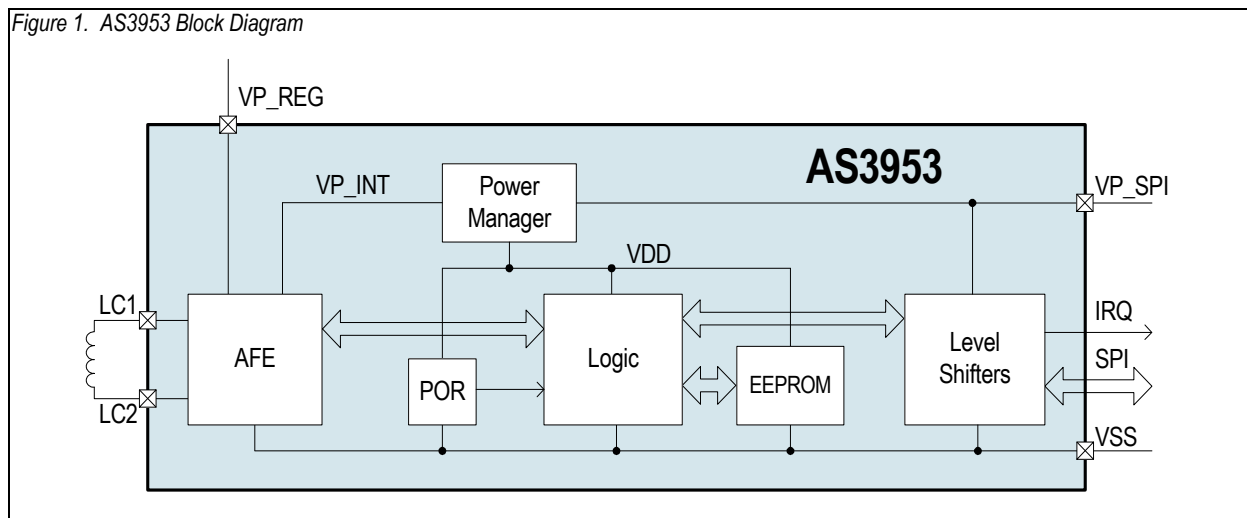



Copyrights

Copyright © 1997-2012, ams AG, Tobelbaderstrasse 30, 8141 Unterpemstaetten, Austria-Europe. Trademarks Registered ®. All rights reserved. The material herein may not be reproduced, adapted, merged, translated, stored, or used without the prior written consent of the copyright owner.

All products and companies mentioned are trademarks or registered trademarks of their respective companies.

Disclaimer

Devices sold by ams AG are covered by the warranty and patent indemnification provisions appearing in its Term of Sale. ams AG makes no warranty, express, statutory, implied, or by description regarding the information set forth herein or regarding the freedom of the described devices from patent infringement. ams AG reserves the right to change specifications and prices at any time and without notice. Therefore, prior to designing this product into a system, it is necessary to check with ams AG for current information. This product is intended for use in normal commercial applications. Applications requiring extended temperature range, unusual environmental requirements, or high reliability applications, such as military, medical life-support or life-sustaining equipment are specifically not recommended without additional processing by ams AG for each application. For shipments of less than 100 parts the manufacturing flow might show deviations from the standard production flow, such as test flow or test location.

The information furnished here by ams AG is believed to be correct and accurate. However, ams AG shall not be liable to recipient or any third party for any damages, including but not limited to personal injury, property damage, loss of profits, loss of use, interruption of business or indirect, special, incidental or consequential damages, of any kind, in connection with or arising out of the furnishing, performance or use of the technical data herein. No obligation or liability to recipient or any third party shall arise or flow out of ams AG rendering of technical or other services.



Contact Information

Headquarters

ams AG
Tobelbaderstrasse 30
A-8141 Unterpemstaetten, Austria

Tel : +43 (0) 3136 500 0
Fax : +43 (0) 3136 525 01

For Sales Offices, Distributors and Representatives, please visit:

<http://www.ams.com/contact>