

REVISIONS					
REV	ECO	DESCRIPTION	DATE	BY	APPR
A1	-	RELEASE NEW DRAWING	NOV/04/22	LUCAS	TOMMY

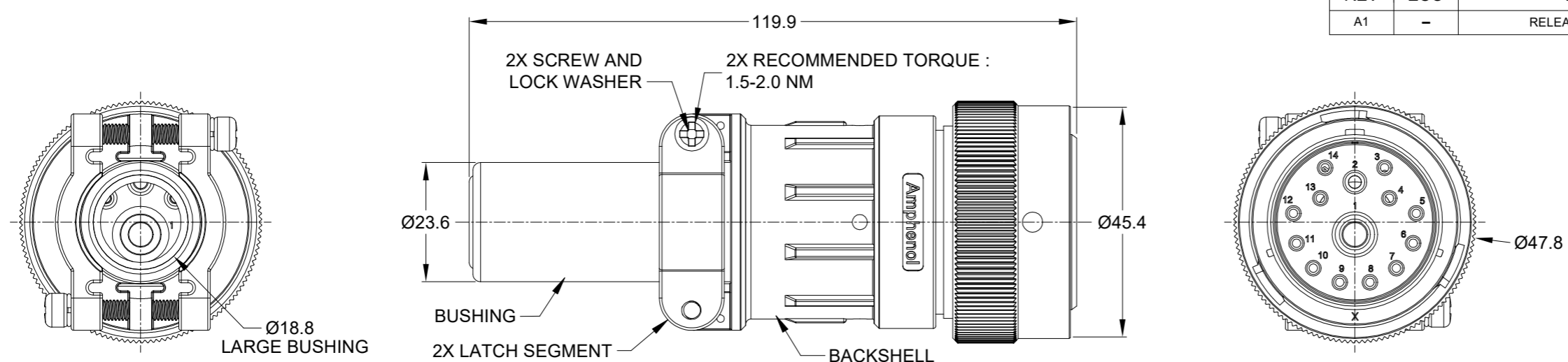

NOTES: UNLESS OTHERWISE SPECIFIED

1. PLUG MATERIAL:

SHELL: ZINC ALLOY, NICKEL PLATED
 COUPLING RING: ALUMINUM ALLOY, ANODIZE
 INSERT AND RETAINING RING: THERMOPLASTIC
 SEAL: SILICONE RUBBER

2. BACKSHELL MATERIAL:

SHELL: ALUMINIUM ALLOY, NICKEL PLATED;
 LATCH SEGMENT: ALUMINIUM ALLOY, NICKEL PLATED;
 SCREW AND LOCK WASHER: STAINLESS STEEL;
 BUSHING: EPDM.

3. SPECIFICATIONS:

- 3.1 OPERATING TEMPERATURE: -55°C TO +125°C.
- 3.2 DIELECTRIC WITHSTANDING VOLTAGE: LESS THAN 2 MILLIAMPS CURRENT LEAKAGE @ 1500 VOLTS AC.
- 3.3 INSULATION RESISTANCE: 1000 MEGOHM MIN @ 25°C.
- 3.4 MOISTURE RESISTANCE:
 IP68(IM OF WATER FOR A PERIOD OF 24 HOURS, MATED CONDITION);
 IP69K(MATED CONDITION).
- 3.5 MATING CYCLE DURABILITY: 100 CYCLES
- 3.6 RoHS COMPLIANT

4. APPLY TO CABLE OD SIZE: Ø11.20-Ø24.08 . CAN BE USED:

- 4.1 WITH LARGE AND SMALL BUSHINGS IN PLACE.
- 4.2 WITH ONLY LARGE BUSHING IN PLACE.
- 4.3 WITH BOTH BUSHINGS REMOVED.

5. ALL DIMENSIONS ARE FOR REFERENCE USE ONLY.

6. SEE SPECIFIC PLUG DRAWING FOR:

- 6.1 CONTACT SIZE AND WIRE RANGE.
- 6.2 RETAINING RING COLOR.
- 6.3 MATING PART(S).
- 6.4 CONTACT LAYOUT AND ALL OTHER SPECIFICATIONS.

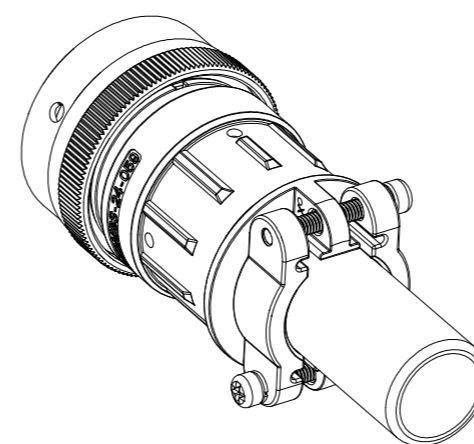

ASSEMBLED

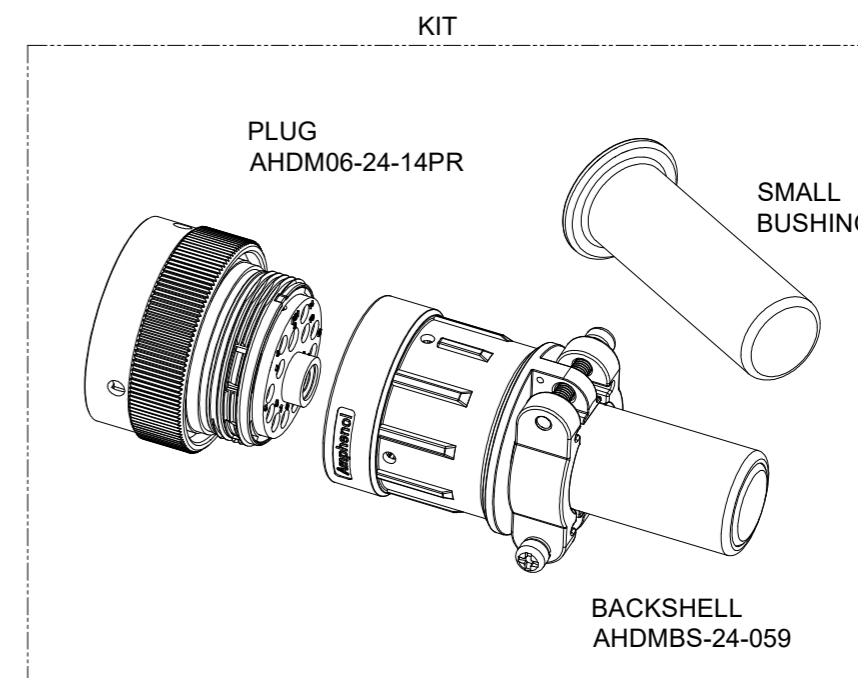

QUANTITY	PART NUMBER	DESCRIPTION	ITEM
	AHDM06-24-14PR-059	REF:HD36-24-14PE-059	

MATERIALS LIST			
UNLESS OTHERWISE SPECIFIED 1) All dimensions are in metric(mm). 2) Tolerances are as follows: 1 PL DEC ±0.30 2 PL DEC ±0.15 3 PL DEC ±0.08 Fractions ±1/64 Angles ±1° 3) Note reference =		SIGNATURES DRAWN: LUCAS CHAI CHECKED: ORION LI ENGINEER: APPROVAL: TOMMY XIE CUSTOMER:	DATE NOV/04/22 NOV/07/22 NOV/10/22
MATERIAL SPECIFICATIONS: WEIGHT: 159.8g		Amphenol Sine Systems - www.amphenol-sine.com 44724 Morley Drive Clinton Township, MI 48036	
PROCESS SPECIFICATIONS:		THIS DRAWING IS SUPPLIED FOR INFORMATION ONLY. DESIGN FEATURES, SPECIFICATIONS AND PERFORMANCE DATA SHOWN HEREON ARE THE PROPERTY OF THE AMPHENOL CORPORATION. NO RIGHTS OF REPRODUCTION ARE IMPLIED. ALL DIMENSIONS ARE SUBJECT TO NORMAL MANUFACTURING VARIATIONS.	
NEXT ASSY:		SIZE B C-	DWG NO: AHDM06-24-14PR-059 REVISION A1
SCALE: NONE		DURAMATE	SHEET 1 OF 1

TITLE: DURAMATE AHDBM PLUG, SIZE 24, RD SEAL, WD THD, KIT W/ CABLE CLAMP BACKSHELL
 DWG NO: AHDM06-24-14PR-059
 REV: A1
 SH: 1
 OF: 1