

10-32 Stud (Shortstop Style) Circuit Breaker

ACBP-N
Gray Body

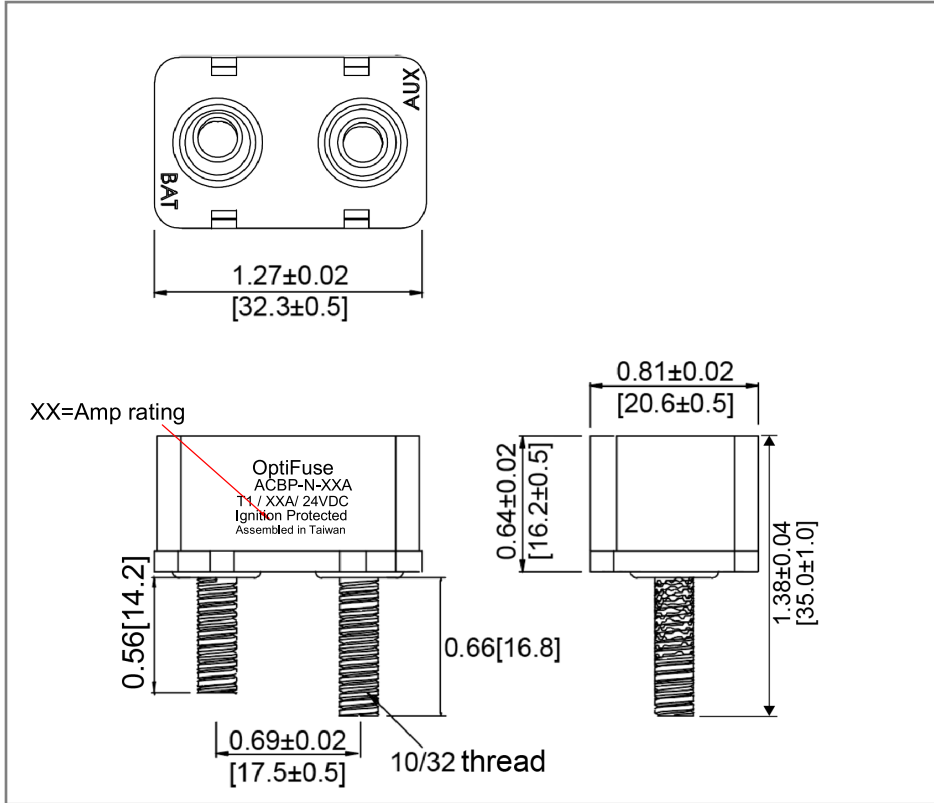

Mechanical Dimensions: Inches [mm]



Part Numbers Information

Amperage	Optifuse P/N
6A	ACBP-N-6A
8A	ACBP-N-8A
10A	ACBP-N-10A
15A	ACBP-N-15A
20A	ACBP-N-20A
25A	ACBP-N-25A
30A	ACBP-N-30A
40A	ACBP-N-40A
50A	ACBP-N-50A

Time vs. Percent of Rated Current

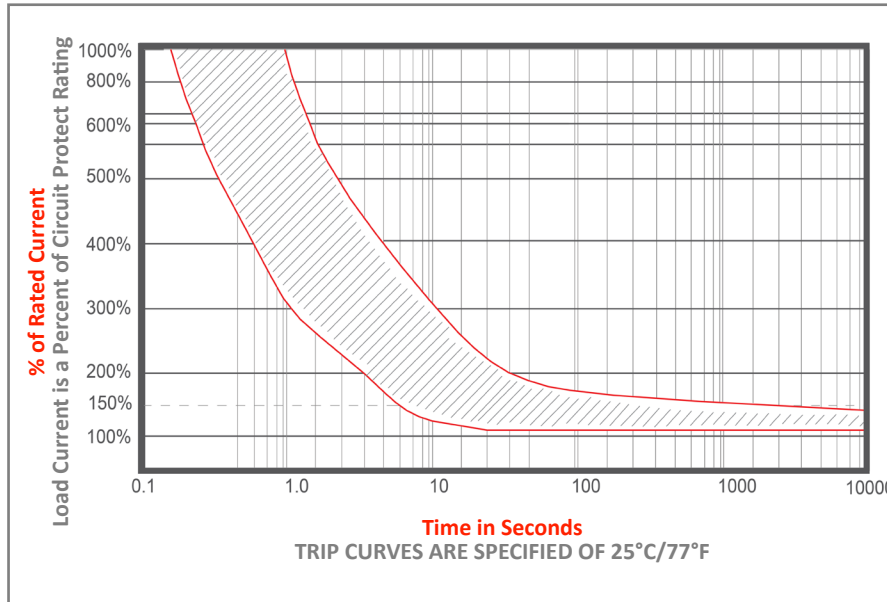

% of Rated Current	Min Trip Time	Max Trip Time
100%	Hold	No Trip
150%		Trip in 1 hr
200%	4.0s	40.0s
300%	1.2s	12.0s
400%	0.6s	5.0s
500%	0.4s	2.8s
600%	0.3s	1.8s

Electrical Specifications

Voltage Rating	12/24/32VDC
Reset Type	Type I - Auto Reset
Interrupting Rating	4 Times Rated Current
Operation Temperature	-10°C ~ 60°C
Testing	SAE J553

Material Specifications

Body Material	Thermoplastic (UL94V-0)
Terminals Material	Battery – Copper Plated, Auxiliary – Zinc Plated
Terminals Configuration	#10-32 stud
Studs Torque	3.0±0.3 N.m
Ignition Protection	SAE J1171 Ingress Protection IP63

Temperature Derating Curve

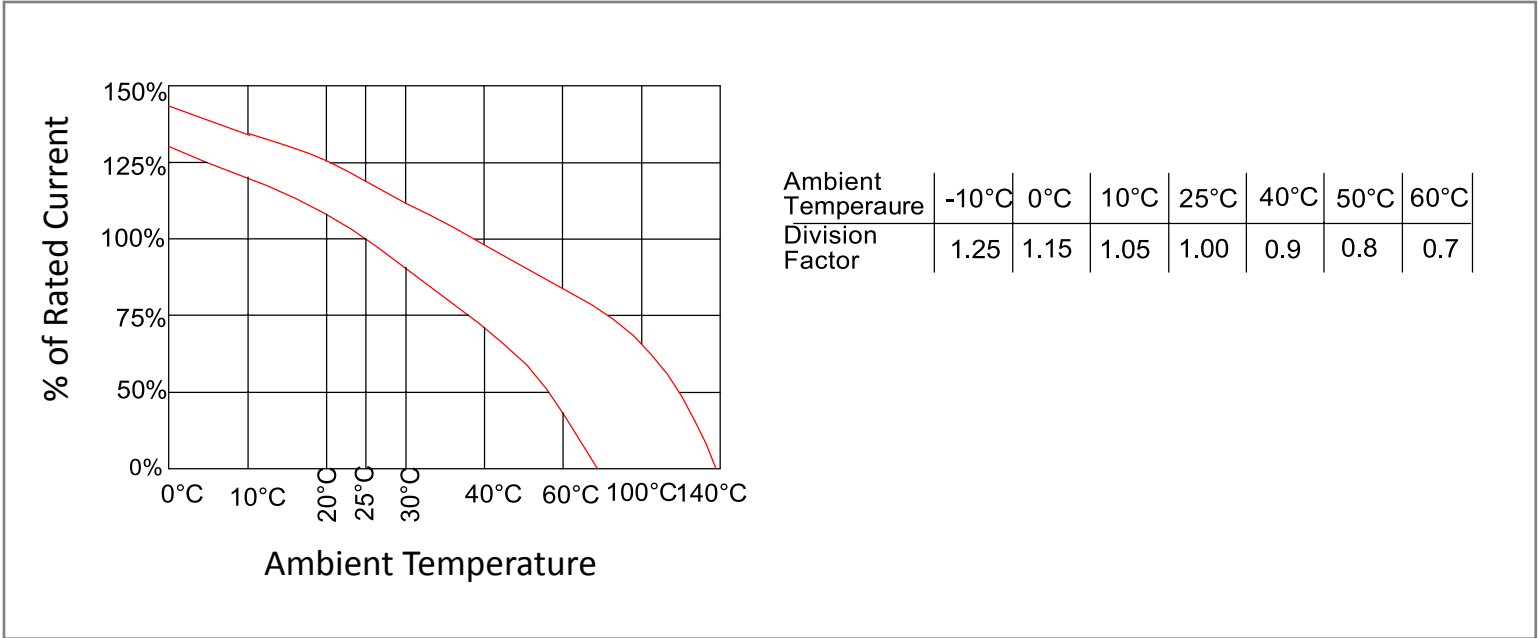

Rev	Date of issue	Revision Notes	Designed	Approved
F	08-14-2023	Initial Drawing	RC	OF