

PART NO.	A98000-100	REV	ECO	DATE	APP
		C	106307	04-01-2020	TLM

MATERIALS

HOUSING:
ALUMINUM 6061, NICKEL PLATE (500 MICROINCHES MINIMUM) PER SAE-AMS-2404

INSULATOR:
LIQUID CRYSTAL POLYMER (LCP) PER ASTM D5138

CONTACT/SOLDERCUP:
BERYLLIUM COPPER PER ASTM B194, C17200, GOLD PLATED PER ASTM B488, (HARD GOLD) TYPE II CODE C, CLASS 1.27

HARDWARE:
AVAILABLE UPON REQUEST

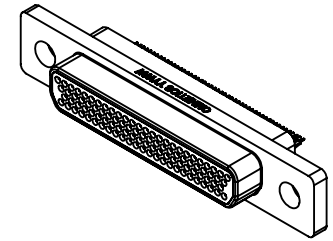
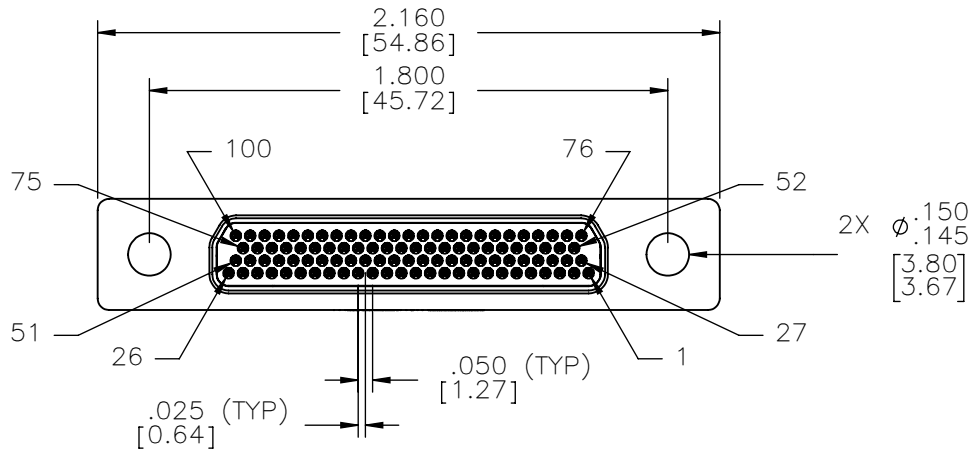

ACTUAL SIZE

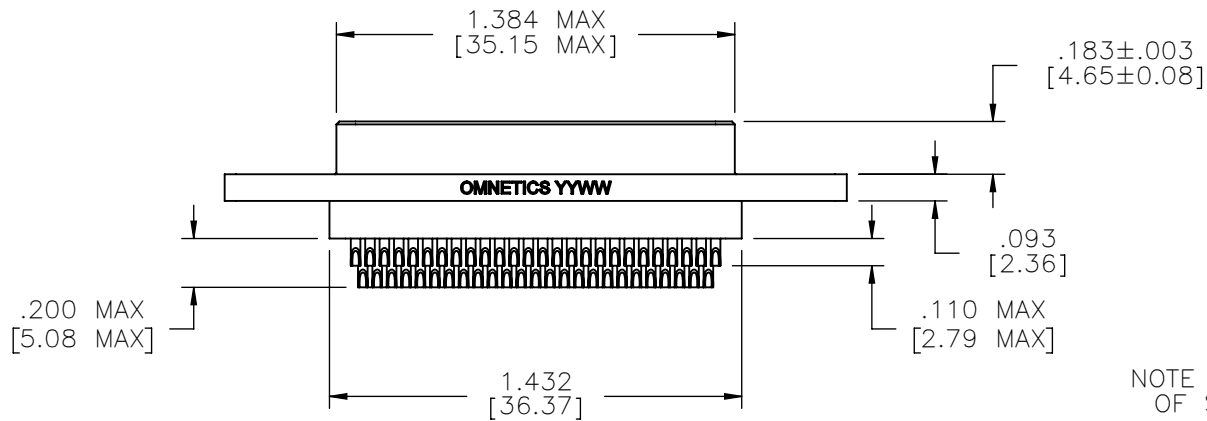

NOTE ORIENTATION OF SOLDERCUPS

RoHS

NOTE:
DIMENSIONS IN [] ARE IN MILLIMETERS UNLESS OTHERWISE NOTED AND ARE FOR REFERENCE ONLY

MDCS SLDW	THIRD ANGLE ϕ ∇
	-TOLERANCES-
	UNLESS OTHERWISE NOTED
	DIMENSIONS IN INCHES
2	PL DEC ± .01
3	PL DEC ± .005
4	PL DEC ± .0005
	ANGLES ± 1°

THIS DRAWING CONTAINS CONFIDENTIAL AND PROPRIETARY INFORMATION WHICH IS THE PROPERTY OF OMNETICS CONNECTOR CORP. THIS DOCUMENT MAY NOT, IN WHOLE OR IN PART, BE DUPLICATED, OR DISCLOSED FOR ANY PURPOSE, WITHOUT WRITTEN PERMISSION FROM OMNETICS CONNECTOR CORP.

DFTM. ERB	DATE	01-30-17
CHK'D.	DATE	
APP'D.	DATE	

TITLE:
(100) PIN MALE
MICRO-D CONNECTOR

OMNETICS
CONNECTOR CORPORATION
7260 COMMERCE CIRCLE EAST
MINNEAPOLIS, MN 55432
WWW.OMNETICS.COM

CAGE CODE	61873
DWG NO.	A98000-100
SHEET 1 OF 1	REV C
SCALE:	3:2