

REVISIONS			
REV	DESCRIPTION	DATE	APPROVED
A	INITIAL RELEASE	10/17/11	J.S.

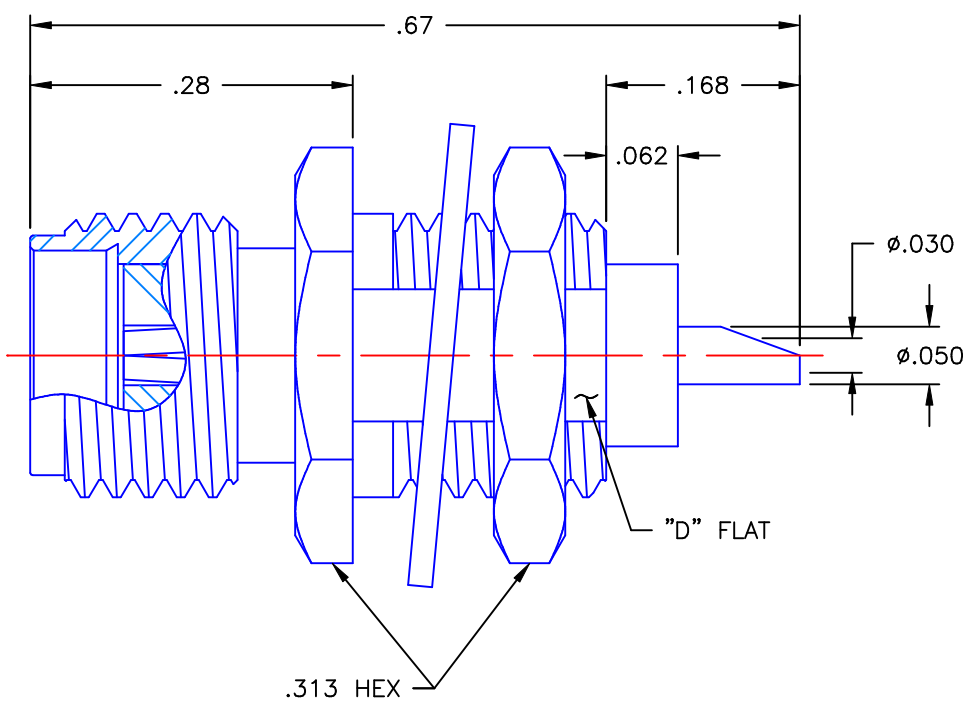

NOTES:

MATERIALS:

1. BODY & NUT = STAINLESS STEEL PER ASTM A582, ALLOY 303, CONDITION "A".
2. INSULATOR = VIRGIN WHITE TEFLON PER ASTM D1710, GRADE 1, TYPE I, CLASS "B".
3. CONTACT = BERYLLIUM COPPER PER ASTM B196, ALLOY C17300, TEMPER TD04.
4. LOCKWASHER = PHOSPHOR BRONZE PER ASTM B139, COPPER ALLOY C53400, TEMPER H04.

FINISHES:

1. CONTACT = GOLD PLATE PER MIL-G-45204, TYPE II, CLASS 1, GRADE C, OVER .00010 TO .00020 STRESS FREE SULFAMATE NICKEL PER QQ-N-290.
2. BODY AND NUT = GOLD PLATE PER MIL-G-45204, TYPE II, CLASS 0, GRADE C, OVER .000050 TO .00010 STRESS FREE NICKEL PER QQ-N-290.
3. LOCKWASHER = GOLD PLATE PER MIL-G-45204, TYPE II, CLASS 0, GRADE C, OVER .00010 TO .00020 COPPER STRIKE PER MIL-C-14550.

UNLESS OTHERWISE SPECIFIED DIMENSIONS ARE IN INCHES TOLERANCES ON	DWN:	DATE	
	J.S.	10/17/11	
	CHKD:	DATE	
DECIMAL	ANGLE	D.N.	10/17/11
		APVD:	DATE
		J.M.	10/17/11

Property of Radiall

This document cannot be reproduced or communicated to a third party without prior written permission of RADIALL.

**AEP**  
a RADIALL company

**SMA STRAIGHT JACK  
BULKHEAD FRONT MOUNT  
SOLDER POT CONTACT**

REFERENCE:	MATERIALS & FINISHES:	SIZE	FSCM NO.	DWG. NO.	REV
ORIGINATOR: J.S. DATE: 10/17/11	SEE NOTES	A	19505	9422-1113-000	A
		SCALE 6:1	THIRD ANGLE PROJECTION		SHEET 1 OF 1

9422-1113-000