

PROPER USE GUIDELINES

Cumulative Trauma Disorders can result from the prolonged use of manually powered hand tools. AMP hand tools are intended for occasional use and low volume applications. AMP offers a wide selection of powered application equipment for extended-use, production operations.

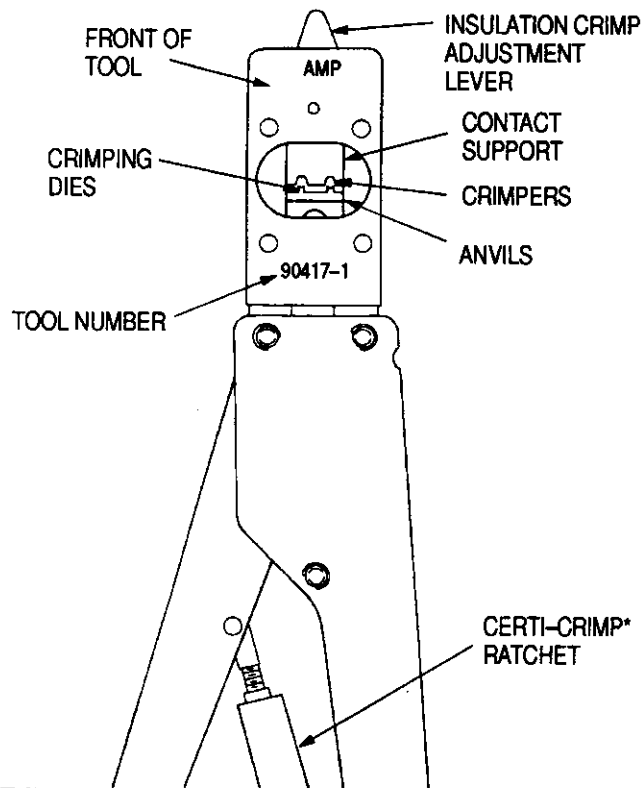

Figure 1

58T-14

1. INTRODUCTION

This instruction sheet covers the use of AMP Hand Crimping Tool 90417-1 which is designed to crimp the AMPMODU* MOD IV 1/2 loose piece contacts shown in Figure 2. Read these instructions thoroughly before using the tool.

Reasons for reissue are provided in Section 6, REVISION SUMMARY.

NOTE

Dimensions on this sheet are in millimeters [with inches in brackets].

2. DESCRIPTION

The FRONT OF TOOL (contact side), into which the contact is inserted, has the tool number marked on it (refer to Figure 1). The BACK OF TOOL (wire side) has the wire size marked above each crimp section (refer to Figure 3). The tool features two fixed dies (crimpers), two movable dies (anvils), two crimp sections with applicable wire-size markings, a contact support, a locator/insulation stop, a wire stop, an insulation crimp adjustment lever, an ejector, and a CERTI-CRIMP ratchet.

The insulation crimp adjustment lever is used to control the crimp height of the contact insulation barrel. Refer to Paragraph 4.6, Insulation Crimp Adjustment.

The CERTI-CRIMP ratchet assures full crimping of the contact. Once engaged, the ratchet will not release until the handles have FULLY closed.

CAUTION

The crimping dies bottom before the CERTI-CRIMP ratchet releases. This design feature assures maximum electrical and tensile performance of the crimp. Do NOT re-adjust the ratchet.

The locator/insulation stop has two functions. First, it positions the contact between the crimping dies, and second, it aids in locating the wire in the contact. In use, it rests in the locator slot. See Figures 2 and 3.

The wire stop helps to position the contact between the crimping dies and aids in locating the wire in the contact. In use, the contact rests in the wire stop slot.

The contact support prevents the contact from bending during the crimping procedure.

The ejector pulls the contact down and ejects the crimped contact when the handles are fully opened.

3. CRIMPING PROCEDURE

Refer to the chart in Figure 2 and select wire of the specified size and insulation diameter. Strip the wire to the length indicated. Do NOT cut or nick the wire strands.

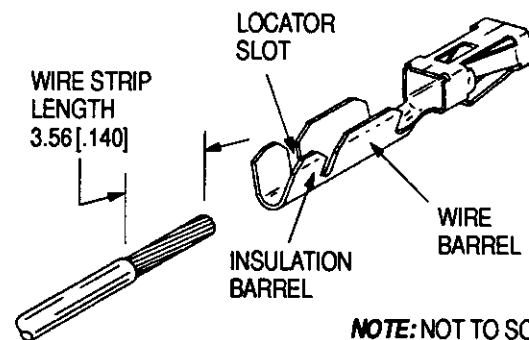

SIZE (AWG)	WIRE	LOOSE PIECE CONTACT*	CRIMP SECTION (Wire Size Marking)
	INSUL DIA (Max.)		
30 to 32	.51 to 1.02	AMPMODU MOD IV 1/2	30 - 32
27 to 28	[.020 to .040]		27 - 28

* For applicable contact part numbers, refer to AMP Catalog 82104.

Figure 2

85-245

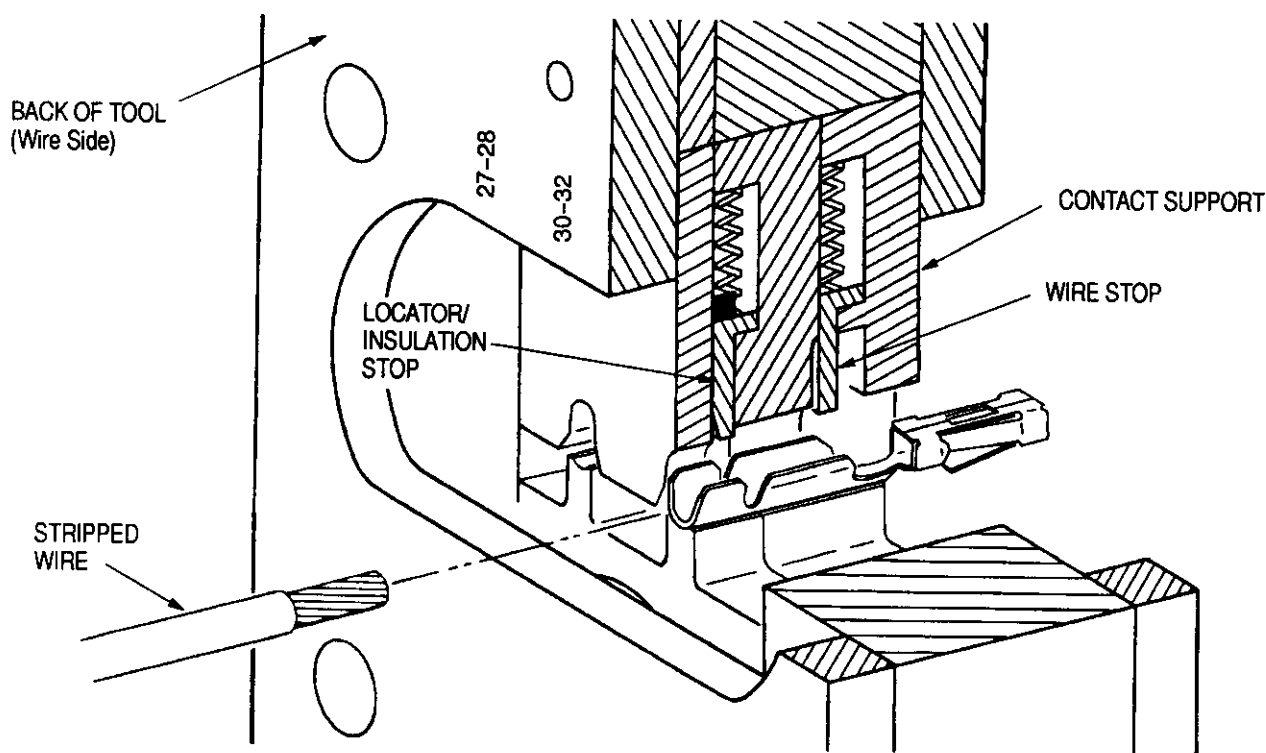

Figure 3

58T-15

On the BACK of the tool, identify the appropriate crimp section (according to the wire size markings).

Refer to Figure 3 and proceed as follows:

1. Hold tool so BACK (wire side) is facing you.
2. Make sure ratchet is released by squeezing the tool handles and allowing them to open FULLY.
3. Insert contact (insulation barrel first) into FRONT of appropriate crimp section. Position the contact in crimpers so that locator enters locator slot in contact.
4. Hold contact in this position and squeeze tool handles together until insulation anvil starts entry into insulation crimper. Do NOT deform insulation barrel or wire barrel.
5. From BACK of tool (wire side) insert a properly stripped wire through wire slot in locator and into wire barrel of contact until insulation butts against locator/insulation stop and wire butts against wire stop.
6. Holding wire in place, squeeze tool handles until ratchet releases.
7. Allow tool handles to open FULLY so that the ejector can push the crimped contact out of the crimpers. Remove crimped contact from tool.

4. MAINTENANCE AND INSPECTION PROCEDURE

AMP recommends that a maintenance and inspection program be performed periodically to ensure dependable and uniform terminations. Frequency of inspection depends on:

1. The care, amount of use, and handling of the hand tool.
2. The presence of abnormal amounts of dust and dirt.
3. The degree of operator skill.
4. Your own established standards.

The hand tool is inspected before being shipped; however, AMP recommends that the tool be inspected immediately upon its arrival at your facility to ensure that the tool has not been damaged during shipment.

Due to the precision design, it is important that no parts of these tools be interchanged except those replacement parts listed in Figure 5.

4.1. Daily Maintenance

1. Remove dust, moisture, and other contaminants with a clean brush, or a soft, lint-free cloth. Do NOT use objects that could damage the tool.
2. Make certain that the retaining pins are in place and that they are secured with retaining rings.

- All pins, pivot points, and bearing surfaces should be protected with a thin coat of any good SAE No. 20 motor oil. Do not oil excessively.
- When the tool is not in use, keep handles closed to prevent objects from becoming lodged in the crimping dies. Store the tool in a clean, dry area.

4.2. Lubrication

Lubricate all pins, pivot points, and bearing surfaces with SAE No. 20 motor oil as follows:

- Tools used in daily production – lubricate daily
- Tools used daily (occasional) – lubricate weekly
- Tools used weekly – lubricate monthly

Wipe excess oil from tool, particularly from crimping area. Oil transferred from the crimping area onto certain terminations may affect the electrical characteristics of an application.

4.3. Periodic Inspection

- Hand tool should be immersed (handles partially closed) in a reliable commercial degreasing compound to remove accumulated dirt, grease, and foreign matter.
- Close tool handles until ratchet releases and then allow them to open freely. If they do not open quickly and fully, the spring is defective and must be replaced. See Section 5, REPLACEMENT AND REPAIR.
- Inspect head assembly for worn, cracked, or broken dies. If damage is evident, return the tool to AMP for evaluation and repair. See Section 5, REPLACEMENT AND REPAIR.

4.4. Crimp Height Inspection

This inspection requires the use of micrometer with a modified anvil as shown in Figure 4. AMP recommends use of the modified micrometer (Crimp Height Comparator RS-1019-5LP) which can be purchased from:

York Machinery & Supply Co. VALCO
 20 North Penn Street or 1410 Stonewood Drive
 York, PA 17401-1014 Bethlehem, PA 18017-3527

Proceed as follows:

- Refer to the chart in Figure 4 and select a contact and a wire (maximum size) for each crimp section listed in the chart.
- Refer to Section 3, CRIMPING PROCEDURE, and crimp the contact(s) accordingly.
- Using a crimp height comparator, measure wire barrel crimp height as shown in Figure 4. If the crimp height conforms to that shown in the chart, the tool is considered dimensionally correct. If not,

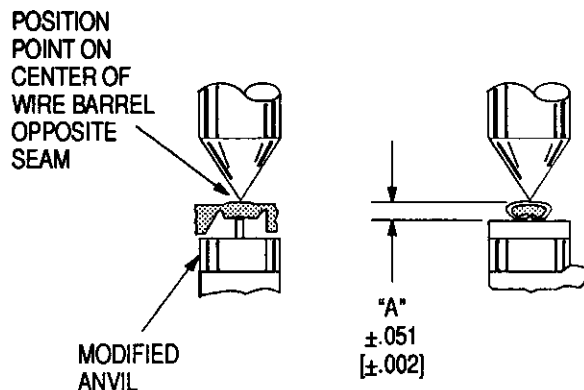

CONTACT	WIRE SIZE AWG (Max)	CRIMP SECT (Wire Size Marking)	CRIMP HGT DIM. "A"
AMP MODU MOD IV 1/2	30	30 - 32	.59 [.022]
	27	27 - 28	

Figure 4

return the tool to AMP for evaluation and repair (refer to Section 5, REPLACEMENT AND REPAIR).

For additional information concerning the use of the crimp height comparator, refer to AMP instruction sheet 408-7424.

4.5. CERTI-CRIMP Ratchet Inspection

The CERTI-CRIMP ratchet feature on AMP hand tools should be checked to ensure that the ratchet does not release prematurely, allowing the crimping dies to open before they have fully bottomed. Obtain a 0.025-mm [.001-in.] shim that is suitable for checking the clearance between the bottoming surfaces of the crimping dies. Proceed as follows:

- Select the maximum size wire and strip it according to dimensions listed in Figure 2.
- Select contact and crimp section corresponding to the selected wire size (refer to Figure 2).
- Position the contact and wire between the crimping dies, as described in Section 3, CRIMPING PROCEDURE.
- Hold the wire in place and squeeze the handles until the CERTI-CRIMP ratchet releases. Hold the handles in this position, maintaining just enough tension to keep the dies closed.
- Check the clearance between the bottoming surfaces of the crimping dies. If the clearance is 0.025 mm [.001 in.] or less, the ratchet is satisfactory. If clearance exceeds 0.025 mm

[.001 in.], the ratchet is out of adjustment and must be repaired. See Section 5, REPLACEMENT AND REPAIR.

4.6. Insulation Crimp Adjustment

The insulation barrel crimp height is controlled by the insulation adjustment lever. To determine the proper setting, test crimp a contact using the setting which approximates the insulation size (1-small, 2-medium, 3-large). If the crimped insulation barrel is too tight or too loose, change the setting accordingly. The crimp should hold the insulation firmly without cutting into it.

5. REPLACEMENT AND REPAIR

Replacement parts are listed in Figure 5. Parts other than those listed in Figure 5 should be replaced by AMP to ensure quality and reliability of the tool. Order replacement parts through your AMP representative, or call 1-800-526-5142, or send a facsimile of your purchase order to 1-717-986-7605, or write to:

CUSTOMER SERVICE (38-35)
AMP INCORPORATED
P.O. BOX 3608
HARRISBURG, PA 17105-3608

For tool repair service or CERTI-CRIMP ratchet adjustment, return the tool, with a written description of the problem, to:

CUSTOMER REPAIR (01-12)
AMP INCORPORATED
1523 NORTH 4TH STREET
HARRISBURG, PA 17102-1604

6. REVISION SUMMARY

This is a summary of changes and additions made to this instruction sheet.

EC M-3105 authorized the following changes:

- Crimp height dimension changed per engineering specifications

EC 0990-0252-93 authorized the following changes:

- New document format
- Metric measurements added
- EC number(s) added
- Revision letter added
- Revision Summary added
- Deleted contact part numbers and added reference to AMP catalog

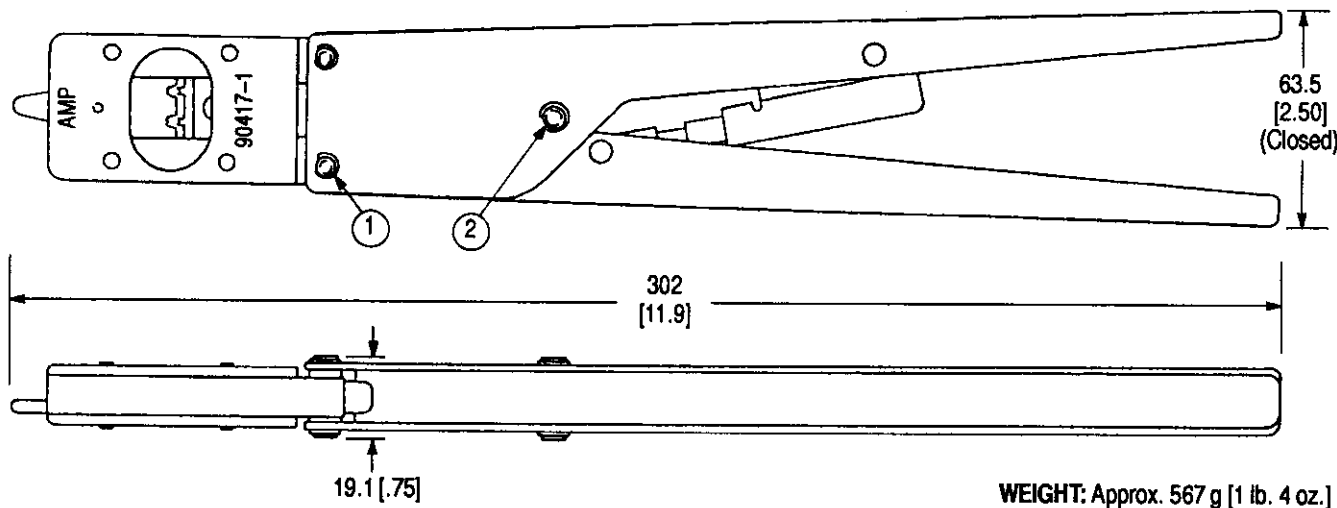

ITEM	PART NUMBER	DESCRIPTION	QTY
1	21045-3	RING, Retaining	1
2	21045-9	RING, Retaining	1

Figure 5

58T-14A