

IMM M22 panel mount LED multi colour beacon

- Ø 45 mm panel-mount LED multi-colour steady beacon
- RED, YELLOW or GREEN, can be switched externally
- High degree of protection IP 67
- Prewired with 1 m UL cable
- Modern LED technology and electronics
- Good signalling effect
- For industrial and general applications
- Panel size Ø 22.5 mm/M22
- Adapter available for M30.5 mm panel size

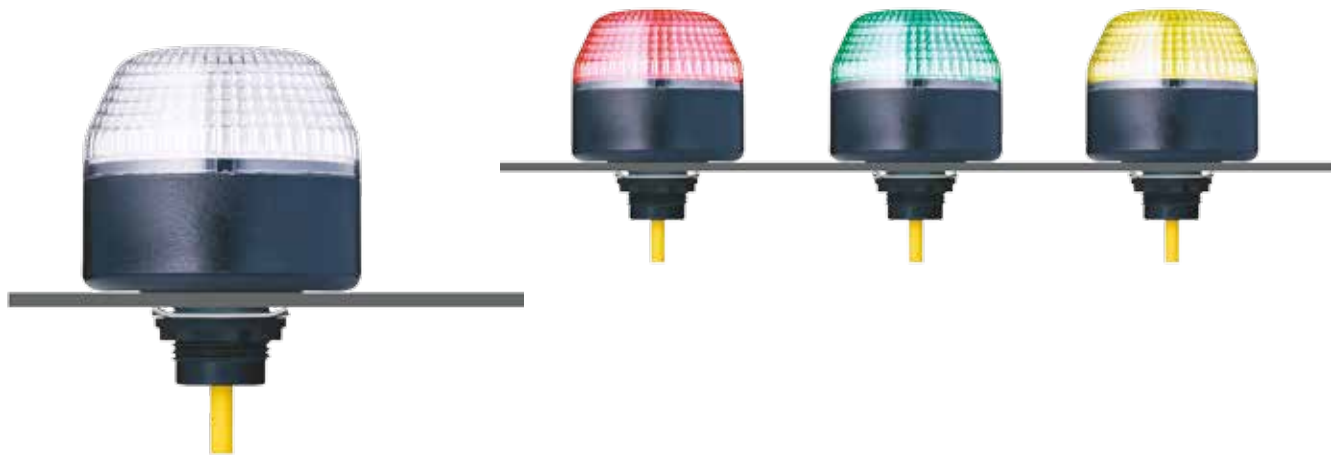

TECHNICAL DATA

Housing	Ø 45 mm, Polycarbonate black (RAL 9005) or grey (RAL 7035)
Lens	Polycarbonate, ribbed inside clear
Type of mounting	any
Panel size	22×1,25 mm (M22) and 30.5 mm (with adapter), mounting depth 34 mm
Cable entry	pre-wired (1 m cable)
Leakage current	0,003 A (PLC-suitable)
Beacon type	LED steady beacon - 3 colour beacon
Light source	9 LEDs
Number of colours	3
Duty cycle	100% (one colour)
Service life	Light source: 100.000 h
Operating temperature	-25°C/+50°C
Degree of protection	IP67 & UL Type 4/4×/13
Weight	97 g

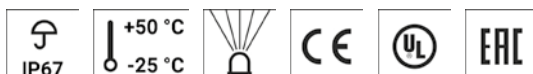
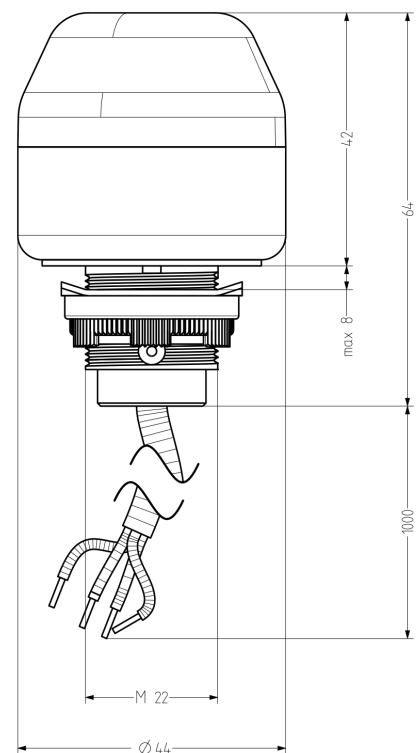

IMM

ORDER DATA

Lens colour	Nominal voltage	Voltage range (V)	Nominal current (A)	Housing colour	
				black	grey
clear	24 V AC/DC	+/- 10 %	0,027	801 550 405	801 150 405



ADM30

ACCESSORIES

Type	Type of accessory	Weight	Order number
ADM30	Adapter for M30.5 for 30.5 mm holes	8 g	812 500 900