

REVISIONS			
REV.	DESCRIPTION	DATE	APPROVED
A	INITIAL RELEASE	04/28/14	D.N.

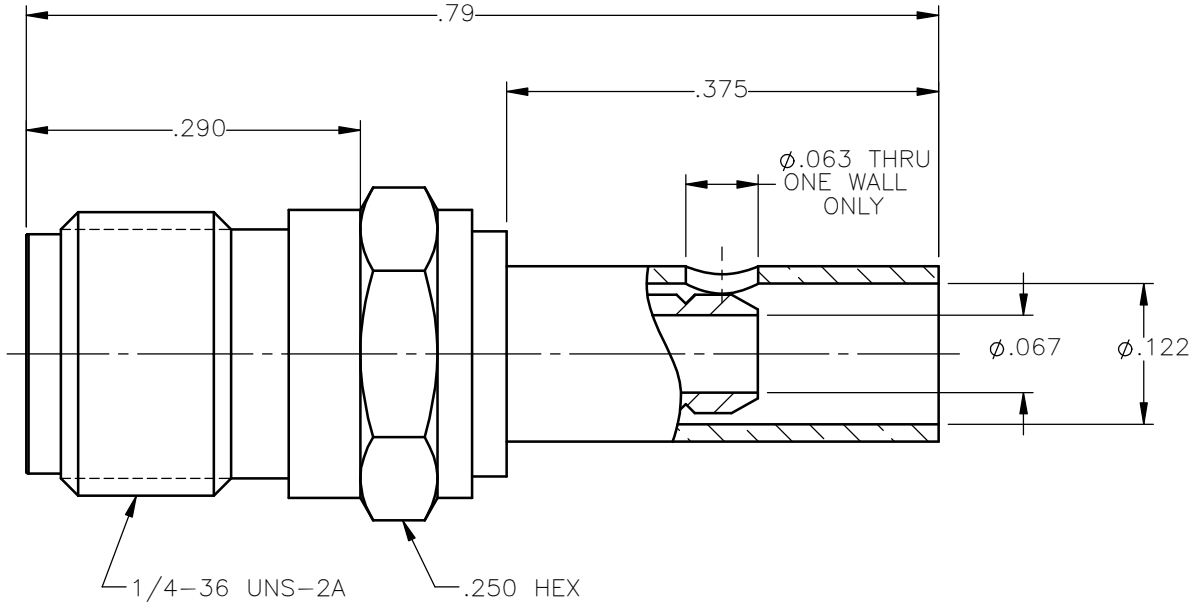

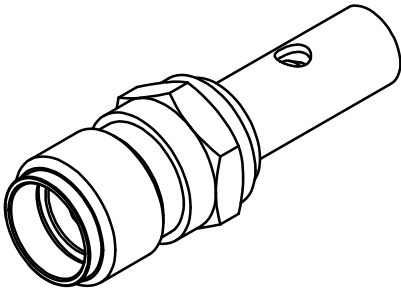

NOTES:

MATERIALS:

1. BODY = STAINLESS STEEL PER ASTM A582, ALLOY 303, CONDITION "A".
2. INSULATOR = VIRGIN WHITE TEFLON PER ASTM D1710, GRADE 1, TYPE I, CLASS "B".
3. CONTACT = BERYLLIUM COPPER PER ASTM B196, ALLOY C17300, TEMPER TD04.
4. CRIMP SLEEVE = SEAMLESS LOWLEAD BRASS TUBE, ALLOY 330, SOFT ANNEAL TEMPER, .025/.060 GRAIN SIZE OR SEAMLESS COPPER TUBE PER ASTM B75, TYPE C12000, TEMPER: LIGHT ANNEAL O50 EXCEPT YIELD STRENGTH.
5. SHRINK SLEEVE = THERMOFIT SCL, BLACK (NOT SHOWN).

FINISHES:

1. BODY = GOLD PLATE PER ASTM B488-01, TYPE II, 30µin MIN, GRADE C, OVER 50 TO 100µin STRESS FREE NICKEL PER QQ-N-290.
2. CONTACT = GOLD PLATE PER ASTM B488-01, TYPE II, 50µin MIN, GRADE C, OVER 100 TO 200µin STRESS FREE SULFAMATE NICKEL PER QQ-N-290.
3. CRIMP SLEEVE = GOLD PLATE PER ASTM B488-01, TYPE II, 30µin MIN, GRADE C, OVER 100 TO 200µin COPPER STRIKE PER MIL-C-14550.

UNLESS OTHERWISE SPECIFIED DIMENSIONS ARE IN INCHES TOLERANCES ON	DWN:	DATE		Property of Radiall			
	D.N.	04/28/14		This document cannot be reproduced or communicated to a third party without prior written permission of RADIALL.			
DECIMAL	ANGLE	CHKD:	DATE	SMA STRAIGHT JACK SOLDER/CRIMP FOR RG-316 & SIMILAR CABLES			
		J.S.	04/28/14				
		APVD:	DATE	SIZE	FSCM NO.	DWG NO.	REV
		J.M.	04/28/14	A	19505	9002-1033-003	A
REFERENCE:	MATERIALS & FINISHES:	SEE NOTES		SCALE	THIRD ANGLE PROJECTION		SHEET 1 OF 1
ORIGINATED: D.N.				6:1			
DATE: 04/28/14							

9002-1033-003