



SERIES 805 TRIPLE-START ACME THREAD Mighty Mouse Connectors and Cables



Code Red Light Weight Hermetic, Rear Panel Mount, Jam-Nut Bulkhead Feedthrough

CODE RED™



Series 805 Light Weight Hermetic Bulkhead Feedthrough

Aluminum alloy shells provide a lightweight separable connection on both sides of a mounting panel. Code Red encapsulant allows for conventional gold plated, copper alloy contacts for improved electrical performance over traditional glass-to-metal seal nickel iron contacts. Available in shell sizes 8 to 23. 100% tested to meet 1×10^{-7} ccHe/sec @ 1 atm helium leak rate. Mates with all high density triple-start threaded plug connectors with the same polarization and opposite contact genders. Pin and socket configurations include pin to pin, pin to socket, and socket to socket. Please contact the factory for additional finish options.

How To Order							
Sample Part Number	805-128	-07	ME	8-7	P	P	A
Series	805-128 = Bulkhead Feedthrough Receptacle						
Shell Style	-07 = Jam-Nut, Rear Panel Mount						
Shell Material and Finish	ME = Aluminum / Nickel Plate						
Shell Size - Insert Arrangement	See Contact Arrangements Page J-6						
Contact Type ² (Jam-Nut Side)	P = Pin S = Socket						
Contact Type ² (Other Side)	P = Pin S = Socket						
Shell Key Position (See Table I)	A = Normal B = Pos. B C = Pos. C D = Pos. D E = Pos. E F = Pos. F						

Key Position	Key Rotation	
	A	B
A (Normal)	150°	210°
B	75°	210°
C	95°	230°
D	140°	275°
E	75°	275°
F	95°	210°

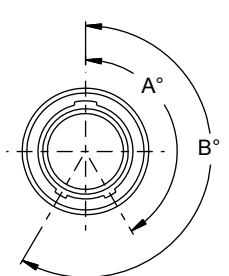

Material and finish

- Shell, jam-nut: aluminum alloy or CRES / see how to order table
- Insulators: liquid crystal polymer / N.A.
- Interfacial seal, O-ring, peripheral seal: fluorosilicone / N.A.
- Contact: copper alloy / gold plate per ASTM B 488, Type II, Code C, Class 1.25, over a suitable underplate

NOTES

1. This connector mates with all quick coupling high density plug connectors with same polarization and opposite contact gender.
2. Sealing compound employed has been tested and meets all applicable performance requirements of MIL-DTL-38999/23.
3. Connector available with pin to pin, socket to socket, and socket to pin contact styles.
4. For pin to pin application, power applied to a given contact on one end will result in power to contact directly opposite, regardless of contact identification letter
5. Feedthrough meets applicable dimensions, mechanical, electrical, environmental and sealing requirements of MIL-DTL-38999/23
6. Operating temperature range: -65°C to +200°C
7. Leak rate: 1×10^{-7} cc/s max helium, 1 ATM
8. IR: 5,000 megohms min at room temperature
9. DWV: 750 VAC (size 23 contacts)
10. See page J-11 for recommended panel cut-outs

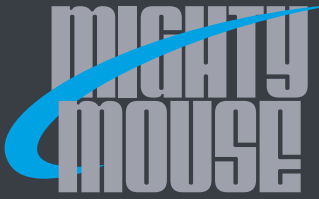

SERIES 805 TRIPLE-START ACME THREAD Mighty Mouse Connectors and Cables



Code Red Light Weight Hermetic, Rear Panel Mount, Jam-Nut Bulkhead Feedthrough

JAM-NUT, REAR PANEL MOUNT - SHELL STYLE 07

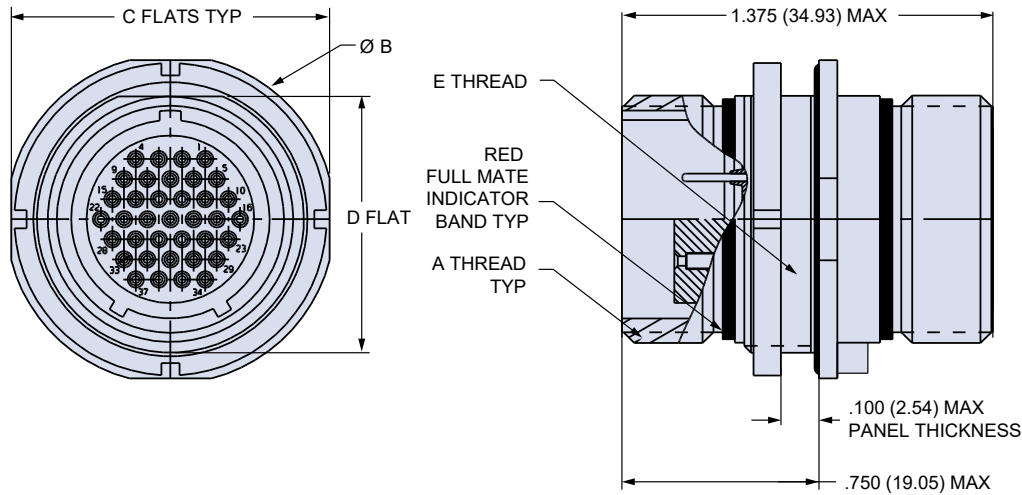

Table II: Dimensions

Shell Size	A Thread	Ø B	C Flat	D Flat	E Thread
8	.5000-1P-.31L-TS	.760 (19.30)	.730 (18.54)	.535 (13.59)	.5625-28 UNEF-2A
9	.5625-1P-.31L-TS	.880 (22.35)	.850 (21.59)	.661 (16.79)	.6875-28 UN-2A
10	.6250-1P-.31L-TS	.880 (22.35)	.850 (21.59)	.661 (16.79)	.6875-28 UN-2A
11	.6875-1P-.31L-TS	.955 (24.26)	.925 (23.50)	.721 (18.31)	.7500-28 UN-2A
12	.7500-1P-.31L-TS	1.060 (26.92)	1.035 (26.29)	.784 (19.91)	.8125-28 UN-2A
13	.8125-1P-.31L-TS	1.120 (28.45)	1.090 (27.69)	.843 (21.41)	.8750-28 UN-2A
15	.9375-1P-.31L-TS	1.203 (30.56)	1.173 (29.79)	.970 (24.64)	1.0000-28 UN-2A
18	1.1250-1P-.31L-TS	1.389 (35.28)	1.359 (34.52)	1.147 (29.13)	1.1875-28 UN-2A
19	1.1875-1P-.31L-TS	1.450 (36.83)	1.420 (36.07)	1.221 (31.01)	1.2500-28 UN-2A
21	1.3125-1P-.31L-TS	1.590 (40.39)	1.560 (39.62)	1.350 (34.29)	1.3750-28 UN-2A
23	1.4375-1P-.31L-TS	1.705 (43.31)	1.675 (42.55)	1.470 (37.34)	1.5000-28 UN-2A

Jam-Nut Panel Cutout

Diagram showing the panel cutout dimensions: H FLAT and Ø J.

Shell Size	H Flat	Ø J
8	.545 (13.84)	.572 (14.53)
	.541 (13.74)	.567 (14.40)
9	.671 (17.04)	.698 (17.73)
	.667 (16.94)	.693 (17.60)
10	.671 (17.04)	.698 (17.73)
	.667 (16.94)	.693 (17.60)
11	.731 (18.57)	.760 (19.30)
	.727 (18.47)	.755 (19.18)
12	.794 (20.17)	.822 (20.88)
	.790 (20.07)	.817 (20.75)
13	.851 (21.62)	.885 (22.48)
	.847 (21.51)	.881 (22.38)
15	.980 (24.89)	1.010 (25.65)
	.976 (24.79)	1.005 (25.53)
18	1.157 (29.39)	1.198 (30.43)
	1.153 (29.29)	1.193 (30.30)
19	1.231 (31.27)	1.260 (32.00)
	1.227 (31.17)	1.255 (31.88)
21	1.358 (34.49)	1.383 (35.13)
	1.354 (34.39)	1.381 (35.08)
23	1.480 (37.59)	1.510 (38.35)
	1.476 (37.49)	1.505 (38.23)

SERIES 805 TRIPLE-START ACME THREAD