

NOTES: UNLESS OTHERWISE SPECIFIED

1. MATERIAL:  
 STD GATOR: NICKEL PLATED STEEL  
 INSULATOR: PVC. AVAILABLE IN ALL TEN COLORS
2. PERFORMANCE:  
 MAX CURRENT: 10 AMPS
3. FEATURES:  
 GATOR JAW OPENING:  $\phi 0.31$  [ $\phi 7.92$ ]

LTR	REVISIONS		DATE	APPROVED
	DESCRIPTION			

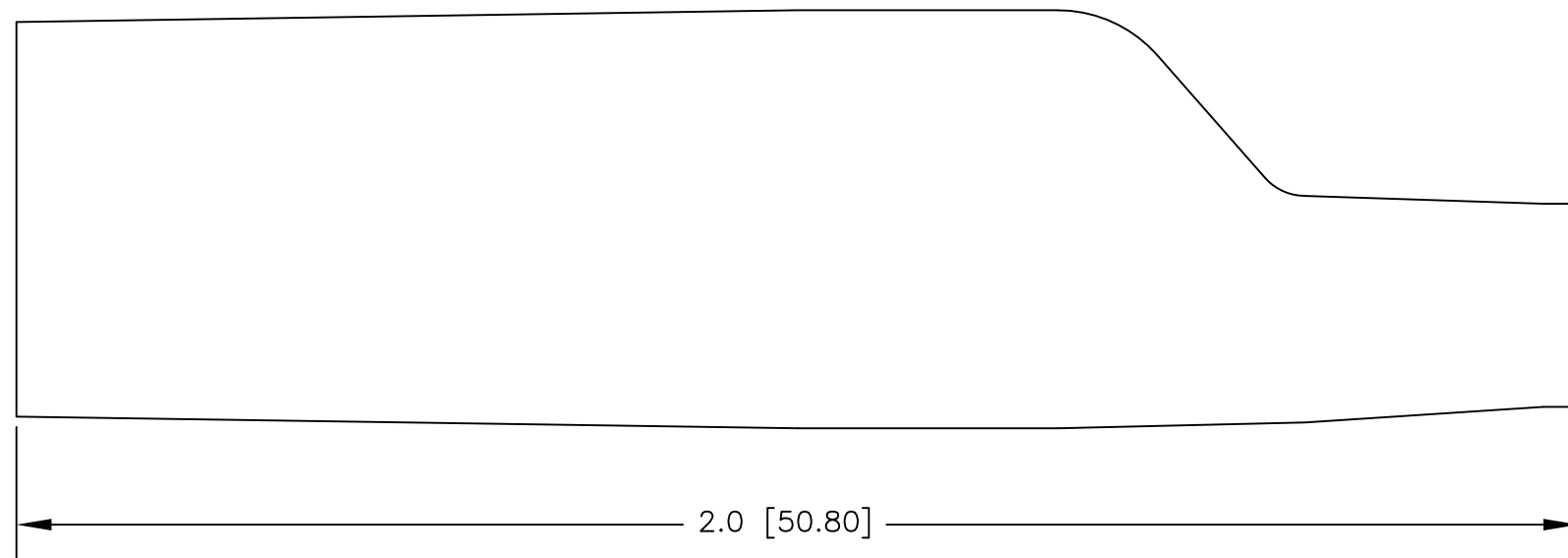
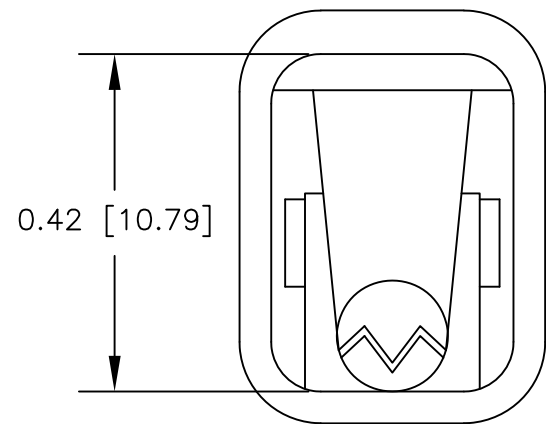

$\phi 0.163$  [ $\phi 4.14$ ]  
 BAN SKT

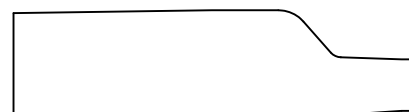
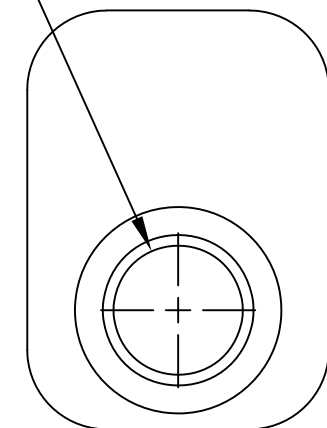

ACTUAL SIZE

		UNLESS OTHERWISE SPECIFIED DIMENSIONS ARE IN INCHES TOLERANCES ARE: FRACTIONS DECIMALS ANGLES ± .XX ± ± .XXX ±	CONTRACT NO.		<b>E-Z-HOOK</b> DIVISION OF TEKTEST INC. ARCADIA, CA 91006 U.S.A.
			APPROVALS	DATE	
		MATERIAL	DRAWN R.L.	2/19	DESCRIPTION STD GATOR TO STD BAN SKT, ADAPTER
		FINISH	APPROVED BY		SIZE CODE IDENT NO. DRAWING NO. REV. B 08505 8016
NEXT ASSY	USED ON				SCALE 4:1 SHEET 1 OF 1
APPLICATION		DO NOT SCALE DRAWING			