

**MATERIALS AND FINISH:**

SHELL: STEEL MATERIAL, NICKEL FINISH  
 INSULATOR: PA9T, UL 94V-0 RATED, BLACK (PROCESS TEMP 260°C)  
 CONTACT MATERIAL: BRASS  
 CONTACT FINISH: SEE PLATING PART NUMBER KEY BELOW  
 SEAL MATERIAL: F08 FLEXIBLE ADHESIVE

**ELECTRICAL:**

CONTACT CURRENT RATING: 3 AMPS  
 CONTACT RESISTANCE: 10 mOHMS Max.  
 DIELECTRIC WITHSTANDING VOLTAGE: 1,000 VAC Min.  
 INSULATION RESISTANCE: 5 GOHMS Min.  
 TEMPERATURE RATING: -55° ~ +125° C

DIMENSIONS (in.)					
No. OF PINS	A	B	C	D	Insulator Material
15	0.665	0.984	1.213	0.090	PA9T
26	0.994	1.311	1.543	0.090	PA9T
44	1.533	1.852	2.089	0.090	PA9T

DIMENSIONS (mm)					
No. OF PINS	A	B	C	D	Insulator Material
15	16.90	25.00	30.80	2.29	PA9T
26	25.25	33.30	39.20	2.29	PA9T
44	38.95	47.05	53.05	2.29	PA9T

**MEETS IP67 STANDARDS**  
 (SEE PAGE 3 FOR SEALING DETAILS)

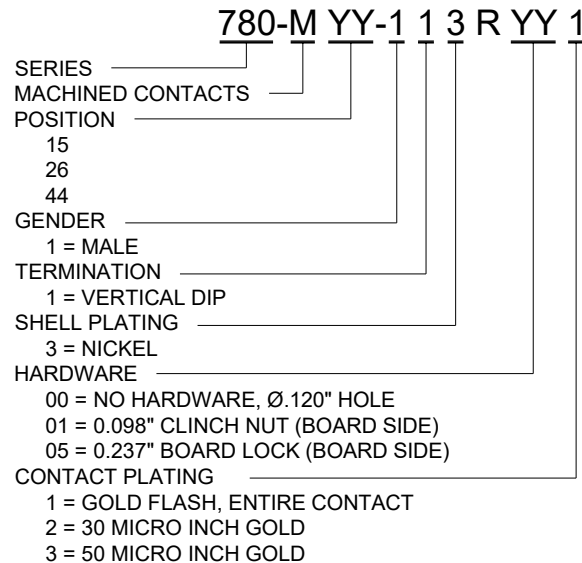

RoHS COMPLIANT

UNITS = INCHES [MM] DO NOT SCALE FROM DRAWING

DRAWN:  
 J. KADEL  
 DATE:  
 08/03/2018

**NorComp**

SCALE: NTS	SHEET 1	OF 4	REV 16
DWG NO. 780-MYY-113RYY1			



THESE DRAWINGS AND SPECIFICATIONS ARE THE PROPERTY OF NorComp AND SHALL NOT BE REPRODUCED, COPIED OR USED AS THE BASIS FOR THE MANUFACTURE OR SALE OF APPARATUS WITHOUT WRITTEN PERMISSION.

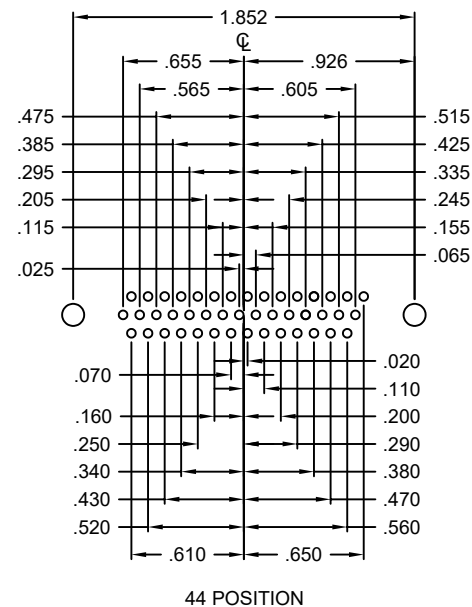
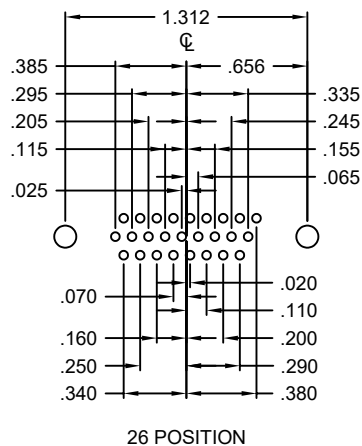
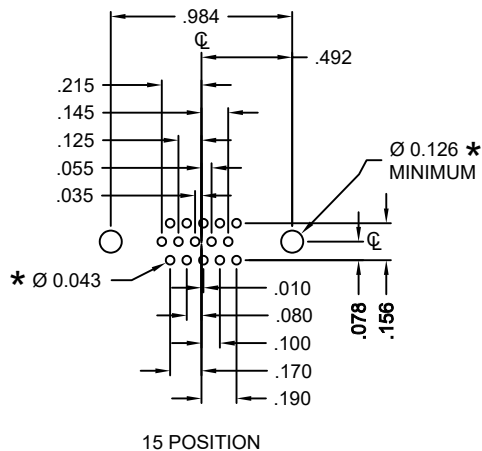

HOLE PATTERN SHOWN  
ARE FOR MALE

UNITS = inch

\* TYP.  
SUGGESTED SIZE  
MAY NOT BE SUITABLE FOR ALL APPLICATIONS

RoHS COMPLIANT

DO NOT SCALE FROM DRAWING



THESE DRAWINGS AND SPECIFICATIONS ARE THE PROPERTY OF NorComp AND SHALL NOT BE REPRODUCED, COPIED OR USED AS THE BASIS FOR THE MANUFACTURE OR SALE OF APPARATUS WITHOUT WRITTEN PERMISSION.

DRAWN:

J. KADEL

DATE:

08/03/2018

NorComp

SCALE:

NTS

SHEET

OF

2

4

REV

16

DWG NO.

780-MYY-113RYY1

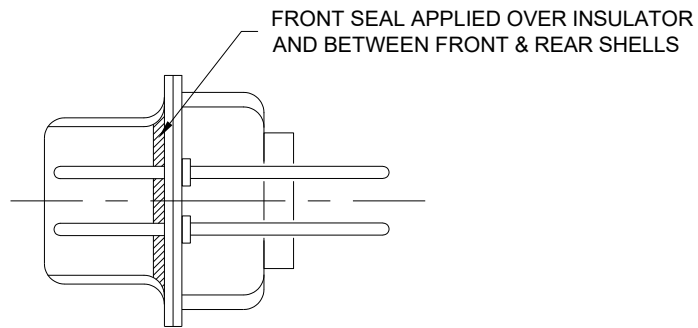
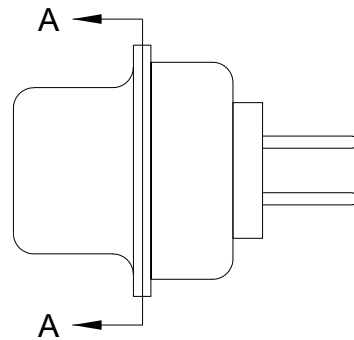

DETAIL A-A

RoHS COMPLIANT

DO NOT SCALE FROM DRAWING



THESE DRAWINGS AND SPECIFICATIONS ARE THE PROPERTY OF NorComp AND SHALL NOT BE REPRODUCED, COPIED OR USED AS THE BASIS FOR THE MANUFACTURE OR SALE OF APPARATUS WITHOUT WRITTEN PERMISSION.

DRAWN:

J. KADEL

DATE:

08/03/2018

NorComp

SCALE:

NTS

SHEET

OF

3

4

REV

16

DWG NO.

780-MYY-113RYY1

ALL CLINCH-NUTS ARE 4-40 INTERNAL THREADS

01X ..... 0.098" (BOARD SIDE)

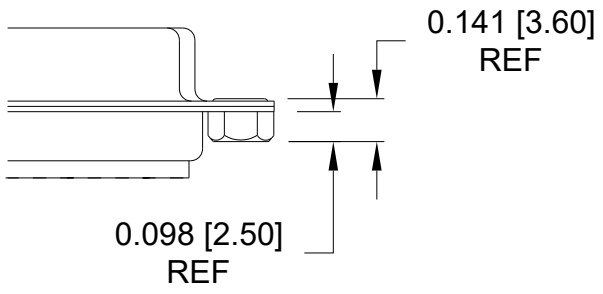

05X ..... 0.237" (BOARD SIDE)

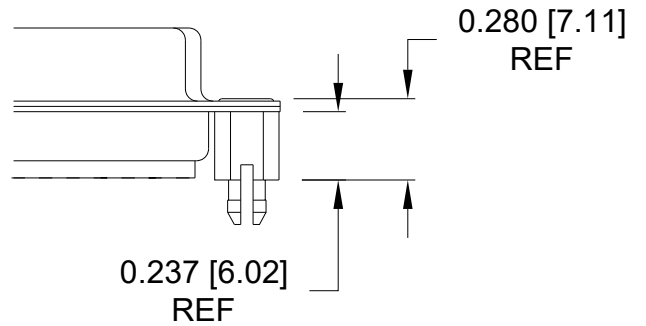

RoHS COMPLIANT

UNITS = INCHES [MM] DO NOT SCALE FROM DRAWING



THESE DRAWINGS AND SPECIFICATIONS ARE THE PROPERTY OF NorComp AND SHALL NOT BE REPRODUCED, COPIED OR USED AS THE BASIS FOR THE MANUFACTURE OR SALE OF APPARATUS WITHOUT WRITTEN PERMISSION.

DRAWN:  
J. KADEL  
DATE:  
08/03/2018

**NorComp**

SCALE: NTS	SHEET 4 OF 4	REV 16
DWG NO. 780-MYY-113RYY1		