

**THIS PRODUCT MANUFACTURED WITH LEAD-FREE PROCESSING**

DO NOT SCALE FROM THIS PRINT

**FIG 1 VERTICAL (6QDP-032-XX.X-STR-5 SHOWN)**

**6QDP-XXX-XX.X-XXX-XXX-X-X**

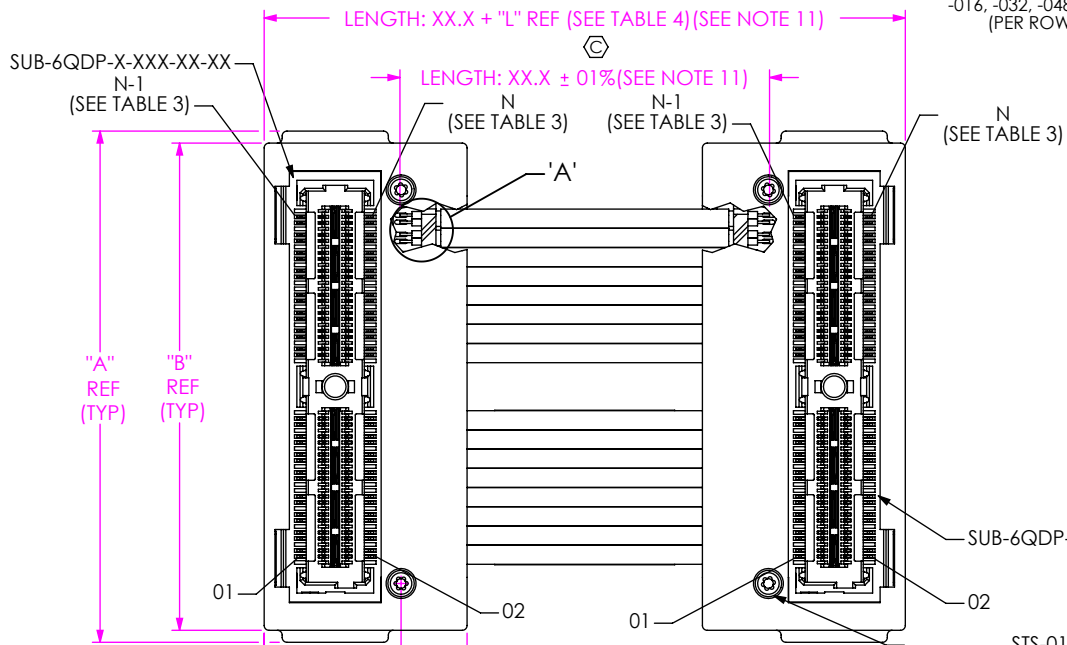

No OF POSITIONS  
-016, -032, -048, -064  
(PER ROW)

LENGTH  
-XX.X (INCHES)  
(1.72 [43.7] MIN)  
(SEE NOTE 2)  
(SEE NOTE 8)

**END OPTION**  
-F: SCREW OPTION FIRST END ONLY  
-S: SCREW OPTION SECOND END ONLY  
-B: SCREW OPTION BOTH ENDS  
-N: NO CAPS  
(SEE FIG 3, SHEET 5 FOR EDGE MOUNT END OPTIONS)  
(SEE FIG 4, SHEET 5 FOR DOUBLE VERTICAL END OPTIONS)  
(SEE FIG 5, SHEET 5 FOR NO CAPS OPTIONS)  
(LEAVE BLANK FOR STANDARD CAPS BOTH ENDS)

**FIRST END**  
-TR: TERMINAL, TOP, RIGHT  
-TL: TERMINAL, TOP, LEFT  
-BR: TERMINAL, BOTTOM, RIGHT  
-BL: TERMINAL, BOTTOM, LEFT  
-STR: SOCKET, TOP, RIGHT  
-STL: SOCKET, TOP, LEFT  
-SBR: SOCKET, BOTTOM, RIGHT  
-SBL: SOCKET, BOTTOM, LEFT  
(SEE TABLE 1 & SHEET 2)  
  
-TEU: TERMINAL, EDGE MOUNT, UP  
-TED: TERMINAL, EDGE MOUNT, DOWN  
(SEE TABLE 5 & SHEET 4)

**WIRING OPTION (SEE NOTE 9)**  
\*\*1: PIN 1 TO PIN 1  
\*\*2: PIN 1 TO PIN 2  
\*\*3: PIN 1 TO PIN N-1  
\*\*4: PIN 1 TO PIN N  
-5: PIN 1 TO PIN 1  
-6: PIN 1 TO PIN 2  
-7: PIN 1 TO PIN N-1  
-8: PIN 1 TO PIN N  
(SEE TABLE 9, SHEET 6)

**SECOND END**  
-TR: TERMINAL, TOP, RIGHT  
-TL: TERMINAL, TOP, LEFT  
-BR: TERMINAL, BOTTOM, RIGHT  
-BL: TERMINAL, BOTTOM, LEFT  
-STR: SOCKET, TOP, RIGHT  
-STL: SOCKET, TOP, LEFT  
-SBR: SOCKET, BOTTOM, RIGHT  
-SBL: SOCKET, BOTTOM, LEFT  
(SEE TABLE 1 & SHEET 3)

-TEU: TERMINAL, EDGE MOUNT, UP  
-TED: TERMINAL, EDGE MOUNT, DOWN  
(SEE TABLE 5 & SHEET 4)

\*\* : AVAILABLE TO EXISTING CUSTOMERS ONLY

**TABLE 3**

No. OF POSITIONS	N	N-1
-016	32	31
-032	64	63
-048	96	95
-064	128	127

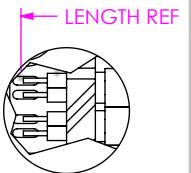
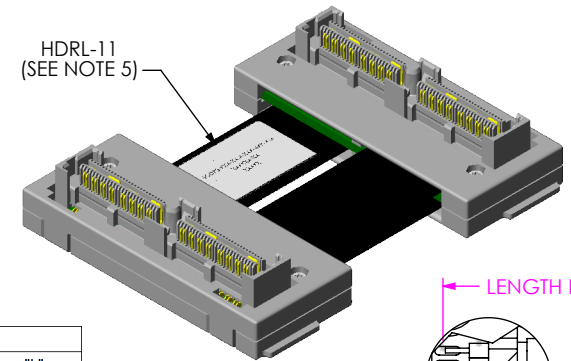
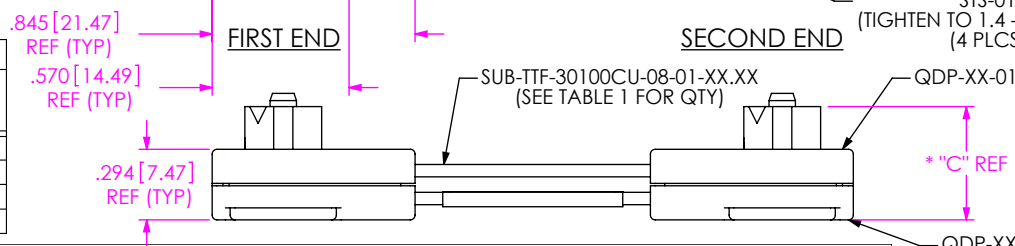

DETAIL 'A'  
SCALE 2.5 : 1

**TABLE 1**

No. OF POSITIONS	WIRING OPTION	"A"	"B"	QDP-XX-01	QDP-XX-02	QTY OF SUB-TTF	SUB-6QDP-X-XXX-XX-XX	SUB-TTF-30100XX-XX-XX-XX
-016	**1, **2, **3, **4	1.290 [32.77]	1.190 [30.23]	QDP-01-01	QDP-01-02	2	SUB-6QDP-X-016-XX-XX	SUB-TTF-30100-XX-01-XX-XX
	-5, -6, -7, -8	1.290 [32.77]	1.190 [30.23]	QDP-01-01	QDP-01-02	2	SUB-6QDP-X-016-XX-XX	SUB-TTF-30100CU-XX-01-XX-XX
-032	**1, **2, **3, **4	2.130 [54.10]	2.030 [51.56]	QDP-02-01	QDP-02-02	4	SUB-6QDP-X-032-XX-XX	SUB-TTF-30100-XX-01-XX-XX
	-5, -6, -7, -8	2.130 [54.10]	2.030 [51.56]	QDP-02-01	QDP-02-02	4	SUB-6QDP-X-032-XX-XX	SUB-TTF-30100CU-XX-01-XX-XX
-048	**1, **2, **3, **4	2.970 [75.44]	2.870 [72.90]	QDP-03-01	QDP-03-02	6	SUB-6QDP-X-048-XX-XX	SUB-TTF-30100-XX-01-XX-XX
	-5, -6, -7, -8	2.970 [75.44]	2.870 [72.90]	QDP-03-01	QDP-03-02	6	SUB-6QDP-X-048-XX-XX	SUB-TTF-30100CU-XX-01-XX-XX
-064	**1, **2, **3, **4	3.810 [96.77]	3.710 [94.23]	QDP-04-01	QDP-04-02	8	SUB-6QDP-X-064-XX-XX	SUB-TTF-30100-XX-01-XX-XX
	-5, -6, -7, -8	3.810 [96.77]	3.710 [94.23]	QDP-04-01	QDP-04-02	8	SUB-6QDP-X-064-XX-XX	SUB-TTF-30100CU-XX-01-XX-XX

**TABLE 4**

END TO END	"L"
DV TO DV	1.121[28.47]
DV TO EM (-TEX)	1.067[27.09]
EM (-TEX) TO EM (-TEX)	1.012[25.70]
DV-N TO DV-N	.979[24.87]
DV-N TO EM-N (-TEX)	1.050[26.67]
EM-N (-TEX) TO EM-N (-TEX)	1.012[25.70]

**TABLE 2**

END	** "C"
-TXX	.444[11.28]
-SXX	.472[11.99]

- \*\* : AVAILABLE TO EXISTING CUSTOMERS ONLY
- NOTES:
- ⊙ REPRESENTS A CRITICAL DIMENSION.
  - SUB-TTF LENGTH IS EQUAL TO 6QDP LENGTH.
  - ALL ASSEMBLIES TO BE 100% ELECTRICALLY TESTED FOR SHORTS AND OPENS.
  - ALL ASSEMBLIES TO BE 100% HI-POT TESTED AT 300V.
  - TOP SUB-TTF NOT SHOWN IN THIS VIEW FOR CLARITY; HDRL-11 TO BE CENTERED ON LOWER SUB-TTF AS SHOWN; HDRL-11 IS TO CONTAIN PART NUMBER, SHOP NUMBER, & DATE CODE.
  - PACKAGE ASSEMBLIES IN STATIC DISSIPATION BAGS.
  - PARTS TO BE PROCESSED PER SAMTEC ACCEPTABILITY REQUIREMENTS: HDR-PI-01 "CABLE ASSEMBLY WORKMANSHIP STANDARDS".
  - CABLE LENGTHS LONGER THAN 40.00 INCHES ARE NOT SUPPORTED BY S.I. TEST DATA.
  - WIRING OPTION -5 THROUGH -8 USE 30100CU.
  - REFER TO PREP-SPEC DOCUMENT FOR CABLE PREP DIMENSIONS. ASSEMBLY USES STANDARD PCB PREP.
  - FOR CABLE LENGTHS LESS THAN 5 INCHES, CABLE LENGTH AND OVERALL LENGTH TOLERANCE IS ±0.05 INCHES. FOR CABLE LENGTHS GREATER THAN 5 INCHES, USE ±1% FOR BOTH

<p>TOLERANCES DO NOT APPLY TO REFERENCE DIMENSIONS. UNLESS OTHERWISE SPECIFIED, DIMENSIONS ARE IN INCHES. TOLERANCES ARE: DECIMALS: .XX: ±.01[.3] .XXX: ±.005[.13] .XXXX: ±.0020[.051]</p>	<p><b>PROPRIETARY NOTE</b> THIS DOCUMENT CONTAINS CONFIDENTIAL AND PROPRIETARY INFORMATION AND ALL DESIGN, MANUFACTURING, REPRODUCTION, USE, PATENT RIGHTS AND SALES RIGHTS ARE EXPRESSLY RESERVED BY SAMTEC, INC. THIS DOCUMENT SHALL NOT BE DISCLOSED, IN WHOLE OR PART, TO ANY UNAUTHORIZED PERSON OR ENTITY NOR REPRODUCED, TRANSFERRED OR INCORPORATED IN ANY OTHER PROJECT IN ANY MANNER WITHOUT THE EXPRESS WRITTEN CONSENT OF SAMTEC, INC.</p>	<p><b>samtec</b> 520 PARK EAST BLVD, NEW ALBANY, IN 47150 PHONE: 812-944-6733 FAX: 812-948-5047 e-Mail: info@SAMTEC.com code: 55322</p>
<p><b>MATERIAL:</b> DO NOT SCALE DRAWING SHEET SCALE: 1:25:1</p> <p><b>PLATING:</b> -H GOLD: 30µ" CONTACT</p>	<p><b>DESCRIPTION:</b> .635mm HIGH-SPEED TWIN-AX CABLE ASSEMBLY</p> <p><b>DWG. NO.</b> 6QDP-XXX-XX.X-XXX-XXX-X-X</p> <p><b>BY:</b> T WHELAN 01/31/06 <b>SHEET 1 OF 7</b></p>	

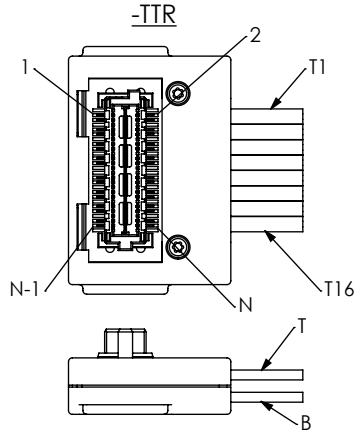

WIRING OPTION	FIRST END PIN #	SECOND END PIN #	WIRE NUMBER
** -1	1	1	B1
** -2	1	2	B1
** -3	1	N-1	B1
** -4	1	N	B1
-5	1	1	B1
-6	1	2	B1
-7	1	N-1	B1
-8	1	N	B1

\*\* : AVAILABLE TO EXISTING CUSTOMERS ONLY

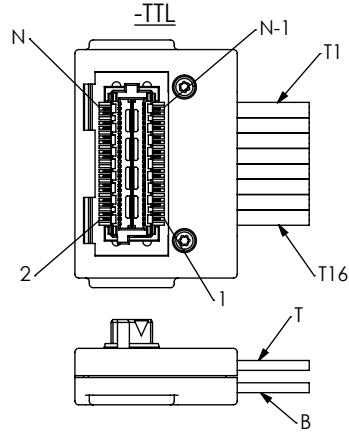

WIRING OPTION	FIRST END PIN #	SECOND END PIN #	WIRE NUMBER
** -1	1	1	T16
** -2	1	2	T16
** -3	1	N-1	T16
** -4	1	N	T16
-5	1	1	T16
-6	1	2	T16
-7	1	N-1	T16
-8	1	N	T16

\*\* : AVAILABLE TO EXISTING CUSTOMERS ONLY

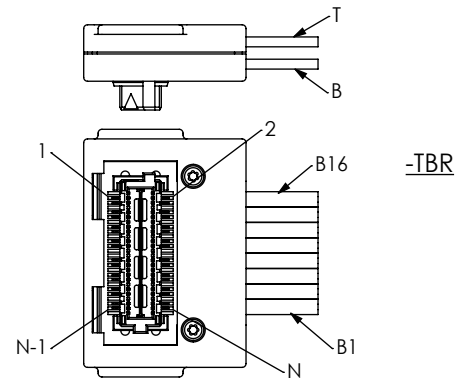

WIRING OPTION	FIRST END PIN #	SECOND END PIN #	WIRE NUMBER
** -1	1	1	T16
** -2	1	2	T16
** -3	1	N-1	T16
** -4	1	N	T16
-5	1	1	T16
-6	1	2	T16
-7	1	N-1	T16
-8	1	N	T16

\*\* : AVAILABLE TO EXISTING CUSTOMERS ONLY

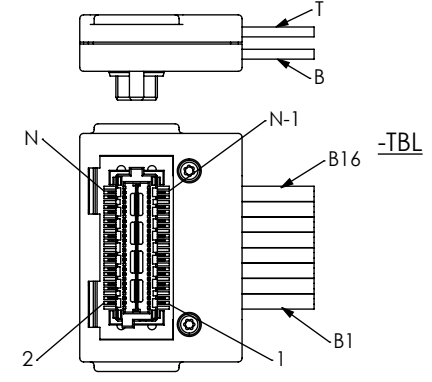

WIRING OPTION	FIRST END PIN #	SECOND END PIN #	WIRE NUMBER
** -1	1	1	B1
** -2	1	2	B1
** -3	1	N-1	B1
** -4	1	N	B1
-5	1	1	B1
-6	1	2	B1
-7	1	N-1	B1
-8	1	N	B1

\*\* : AVAILABLE TO EXISTING CUSTOMERS ONLY

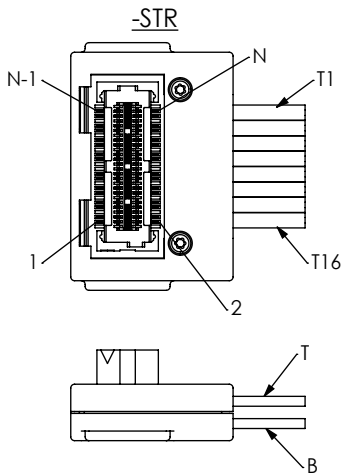

WIRING OPTION	FIRST END PIN #	SECOND END PIN #	WIRE NUMBER
** -1	1	1	B16
** -2	1	2	B16
** -3	1	N-1	B16
** -4	1	N	B16
-5	1	1	B16
-6	1	2	B16
-7	1	N-1	B16
-8	1	N	B16

\*\* : AVAILABLE TO EXISTING CUSTOMERS ONLY

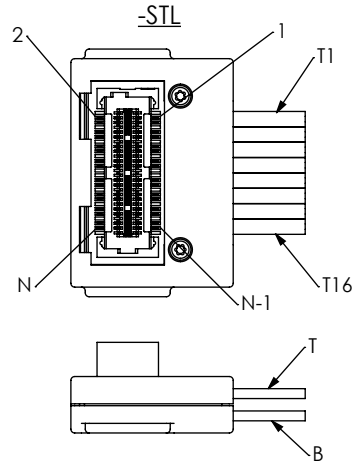

WIRING OPTION	FIRST END PIN #	SECOND END PIN #	WIRE NUMBER
** -1	1	1	T1
** -2	1	2	T1
** -3	1	N-1	T1
** -4	1	N	T1
-5	1	1	T1
-6	1	2	T1
-7	1	N-1	T1
-8	1	N	T1

\*\* : AVAILABLE TO EXISTING CUSTOMERS ONLY

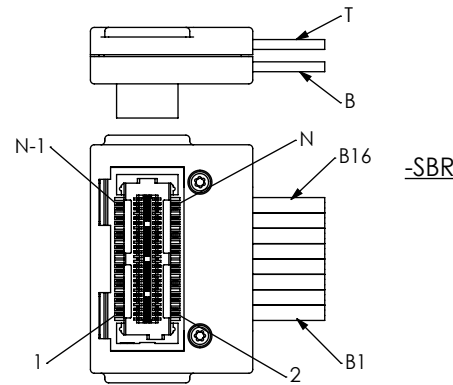

WIRING OPTION	FIRST END PIN #	SECOND END PIN #	WIRE NUMBER
** -1	1	1	T1
** -2	1	2	T1
** -3	1	N-1	T1
** -4	1	N	T1
-5	1	1	T1
-6	1	2	T1
-7	1	N-1	T1
-8	1	N	T1

\*\* : AVAILABLE TO EXISTING CUSTOMERS ONLY

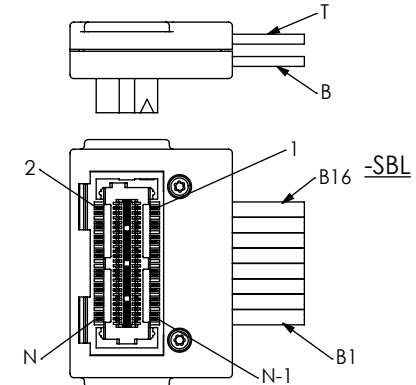

WIRING OPTION	FIRST END PIN #	SECOND END PIN #	WIRE NUMBER
** -1	1	1	B16
** -2	1	2	B16
** -3	1	N-1	B16
** -4	1	N	B16
-5	1	1	B16
-6	1	2	B16
-7	1	N-1	B16
-8	1	N	B16

\*\* : AVAILABLE TO EXISTING CUSTOMERS ONLY

**PROPRIETARY NOTE**  
 THIS DOCUMENT CONTAINS CONFIDENTIAL AND PROPRIETARY INFORMATION AND ALL DESIGN, MANUFACTURING, REPRODUCTION, USE, PATENT RIGHTS AND SALES RIGHTS ARE EXPRESSLY RESERVED BY SAMTEC, INC. THIS DOCUMENT SHALL NOT BE DISCLOSED, IN WHOLE OR PART, TO ANY UNAUTHORIZED PERSON OR ENTITY NOR REPRODUCED, TRANSFERRED OR INCORPORATED IN ANY OTHER PROJECT IN ANY MANNER WITHOUT THE EXPRESS WRITTEN CONSENT OF SAMTEC, INC.

DO NOT SCALE DRAWING

SHEET SCALE: 1:25:1



520 PARK EAST BLVD, NEW ALBANY, IN 47150  
 PHONE: 812-944-6733 FAX: 812-948-5047  
 e-Mail: info@SAMTEC.com code: 53322

DESCRIPTION:  
 .635mm HIGH-SPEED TWIN-AX CABLE ASSEMBLY

DWG. NO.  
 6QDP-XXX-XX.X-XXX-XXX-X-X

BY: T WHELAN 01/31/06 SHEET 2 OF 7

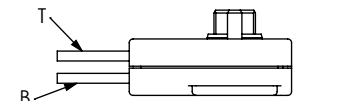
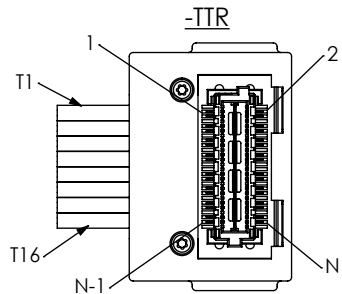

WIRING OPTION	FIRST END PIN #	SECOND END PIN #
**_1	1	1
**_2	1	2
**_3	1	N-1
**_4	1	N
-5	1	1
-6	1	2
-7	1	N-1
-8	1	N

\*\* : AVAILABLE TO EXISTING CUSTOMERS ONLY

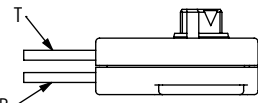
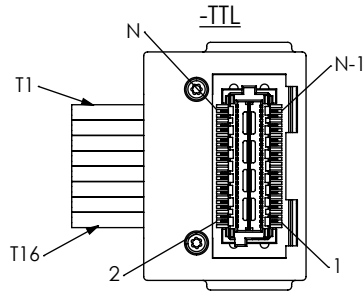

WIRING OPTION	FIRST END PIN #	SECOND END PIN #
**_1	1	1
**_2	1	2
**_3	1	N-1
**_4	1	N
-5	1	1
-6	1	2
-7	1	N-1
-8	1	N

\*\* : AVAILABLE TO EXISTING CUSTOMERS ONLY

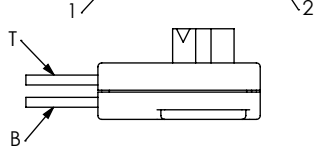
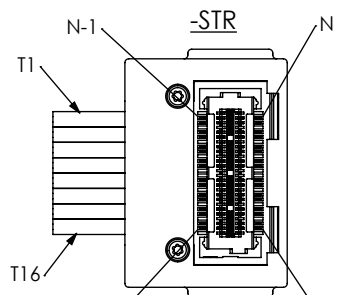

WIRING OPTION	FIRST END PIN #	SECOND END PIN #
**_1	1	1
**_2	1	2
**_3	1	N-1
**_4	1	N
-5	1	1
-6	1	2
-7	1	N-1
-8	1	N

\*\* : AVAILABLE TO EXISTING CUSTOMERS ONLY

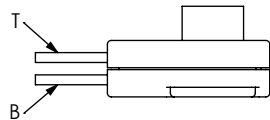
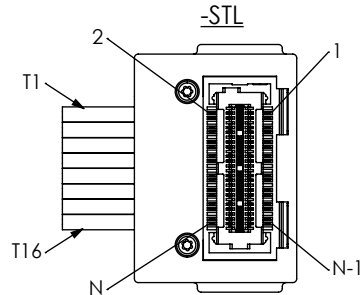

WIRING OPTION	FIRST END PIN #	SECOND END PIN #
**_1	1	1
**_2	1	2
**_3	1	N-1
**_4	1	N
-5	1	1
-6	1	2
-7	1	N-1
-8	1	N

\*\* : AVAILABLE TO EXISTING CUSTOMERS ONLY

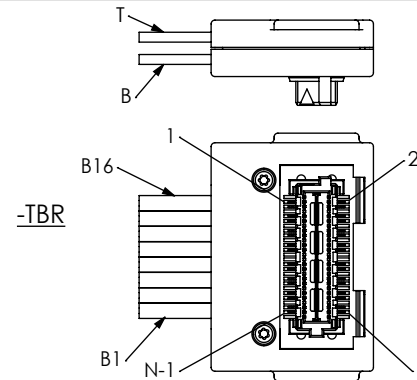

WIRING OPTION	FIRST END PIN #	SECOND END PIN #
**_1	1	1
**_2	1	2
**_3	1	N-1
**_4	1	N
-5	1	1
-6	1	2
-7	1	N-1
-8	1	N

\*\* : AVAILABLE TO EXISTING CUSTOMERS ONLY

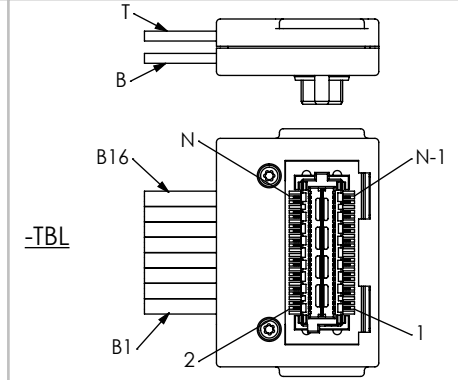

WIRING OPTION	FIRST END PIN #	SECOND END PIN #
**_1	1	1
**_2	1	2
**_3	1	N-1
**_4	1	N
-5	1	1
-6	1	2
-7	1	N-1
-8	1	N

\*\* : AVAILABLE TO EXISTING CUSTOMERS ONLY

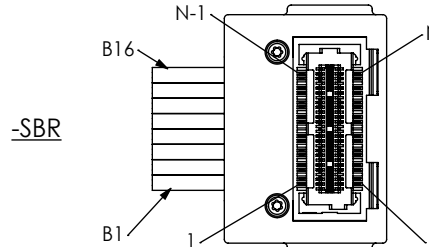
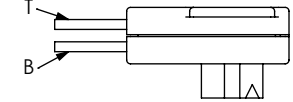
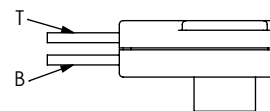

WIRING OPTION	FIRST END PIN #	SECOND END PIN #
**_1	1	1
**_2	1	2
**_3	1	N-1
**_4	1	N
-5	1	1
-6	1	2
-7	1	N-1
-8	1	N

\*\* : AVAILABLE TO EXISTING CUSTOMERS ONLY

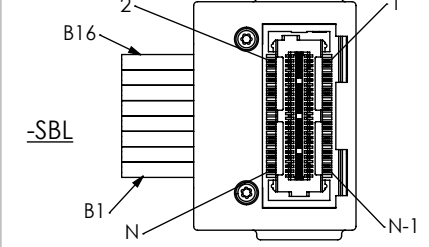

WIRING OPTION	FIRST END PIN #	SECOND END PIN #
**_1	1	1
**_2	1	2
**_3	1	N-1
**_4	1	N
-5	1	1
-6	1	2
-7	1	N-1
-8	1	N

\*\* : AVAILABLE TO EXISTING CUSTOMERS ONLY

**PROPRIETARY NOTE**  
 THIS DOCUMENT CONTAINS CONFIDENTIAL AND PROPRIETARY INFORMATION AND ALL DESIGN, MANUFACTURING, REPRODUCTION, USE, PATENT RIGHTS AND SALES RIGHTS ARE EXPRESSLY RESERVED BY SAMTEC, INC. THIS DOCUMENT SHALL NOT BE DISCLOSED, IN WHOLE OR PART, TO ANY UNAUTHORIZED PERSON OR ENTITY NOR REPRODUCED, TRANSFERRED OR INCORPORATED IN ANY OTHER PROJECT IN ANY MANNER WITHOUT THE EXPRESS WRITTEN CONSENT OF SAMTEC, INC.

DO NOT SCALE DRAWING

SHEET SCALE: 1:25:1



520 PARK EAST BLVD, NEW ALBANY, IN 47150  
 PHONE: 812-944-6733 FAX: 812-948-5047  
 e-Mail: info@SAMTEC.com code: 55322

DESCRIPTION:  
 .635mm HIGH-SPEED TWIN-AX CABLE ASSEMBLY

DWG. NO.  
 6QDP-XXX-XX.X-XXX-XXX-X-X

BY: T WHELAN 01/31/06 SHEET 3 OF 7

FIRST END - EDGE MOUNT (SEE TABLE 9, SHEET 6)

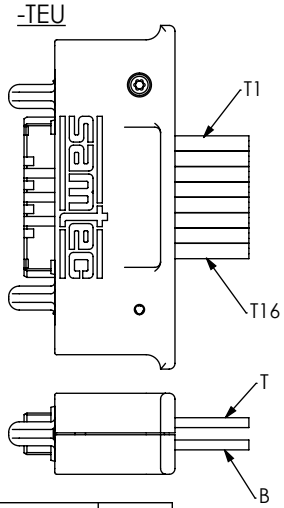
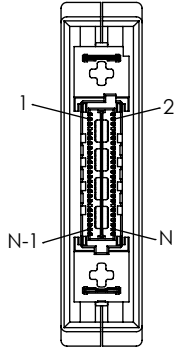

\*\* : AVAILABLE TO EXISTING CUSTOMERS ONLY

WIRING OPTION	FIRST END PIN #	SECOND END PIN #	WIRE #
**-1	1	1	T16
**-2	1	2	T16
**-3	1	N-1	T16
**-4	1	N	T16
-5	1	1	T16
-6	1	2	T16
-7	1	N-1	T16
-8	1	N	T16

-TED

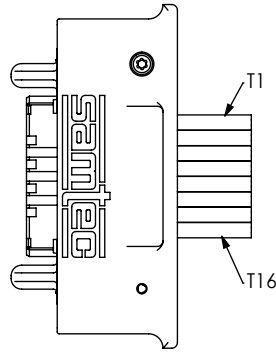
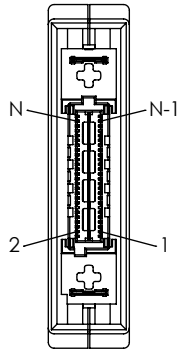
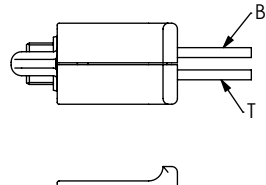

WIRING OPTION	FIRST END PIN #	SECOND END PIN #	WIRE #
**-1	1	1	B1
**-2	1	2	B1
**-3	1	N-1	B1
**-4	1	N	B1
-5	1	1	B1
-6	1	2	B1
-7	1	N-1	B1
-8	1	N	B1

\*\* : AVAILABLE TO EXISTING CUSTOMERS ONLY

SECOND END - EDGE MOUNT (SEE TABLE 9, SHEET 6)

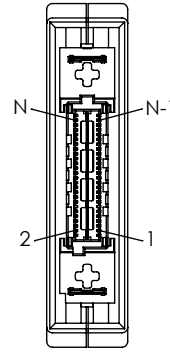
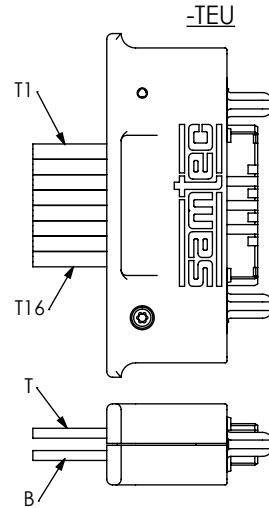

\*\* : AVAILABLE TO EXISTING CUSTOMERS ONLY

WIRING OPTION	FIRST END PIN #	SECOND END PIN #
**-1	1	1
**-2	1	2
**-3	1	N-1
**-4	1	N
-5	1	1
-6	1	2
-7	1	N-1
-8	1	N

-TED

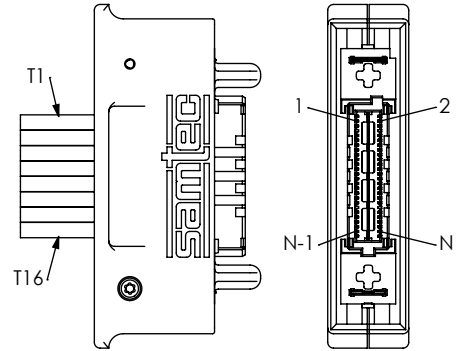
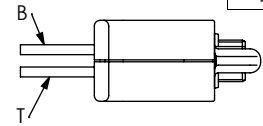

WIRING OPTION	FIRST END PIN #	SECOND END PIN #
**-1	1	1
**-2	1	2
**-3	1	N-1
**-4	1	N
-5	1	1
-6	1	2
-7	1	N-1
-8	1	N

\*\* : AVAILABLE TO EXISTING CUSTOMERS ONLY

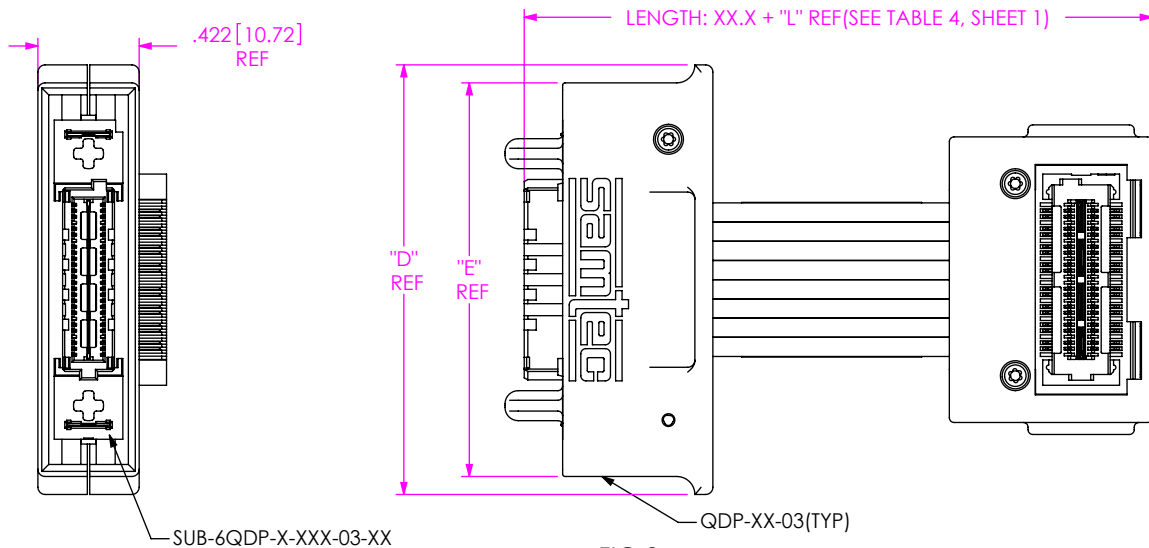

FIG 2  
EDGE MOUNT (NO CAPTIVE PANEL SCREWS)  
(6QDP-016-XX.X-TEU-STL-X SHOWN)  
(SAME AS FIG 1, UNLESS OTHERWISE STATED)

No. OF POSITIONS	"D"	"E"	QDP-XX-03	SUB-6QDP-X-XXX-03-XX
-016	1.790 [45.47]	1.640 [41.66]	QDP-01-03	SUB-6QDP-X-016-03-XX
-032	2.630 [66.80]	2.480 [62.99]	QDP-02-03	SUB-6QDP-X-032-03-XX
-048	3.470 [88.14]	3.320 [84.33]	QDP-03-03	SUB-6QDP-X-048-03-XX
-064	4.310 [109.47]	4.160 [105.66]	QDP-04-03	SUB-6QDP-X-064-03-XX

**PROPRIETARY NOTE**  
THIS DOCUMENT CONTAINS CONFIDENTIAL AND PROPRIETARY INFORMATION AND ALL DESIGN, MANUFACTURING, REPRODUCTION, USE, PATENT RIGHTS AND SALES RIGHTS ARE EXPRESSLY RESERVED BY SAMTEC, INC. THIS DOCUMENT SHALL NOT BE DISCLOSED, IN WHOLE OR PART, TO ANY UNAUTHORIZED PERSON OR ENTITY NOR REPRODUCED, TRANSFERRED OR INCORPORATED IN ANY OTHER PROJECT IN ANY MANNER WITHOUT THE EXPRESS WRITTEN CONSENT OF SAMTEC, INC.

DO NOT SCALE DRAWING

SHEET SCALE: 1:1



520 PARK EAST BLVD, NEW ALBANY, IN 47150  
PHONE: 812-944-6733 FAX: 812-948-5047  
e-Mail: info@SAMTEC.com code: 55322

DESCRIPTION:  
.635mm HIGH-SPEED TWIN-AX CABLE ASSEMBLY

DWG. NO.  
6QDP-XXX-XX.X-XXX-XXX-X-X

BY: T WHELAN 01/31/06 SHEET 4 OF 7

**FIG 3**  
EDGE MOUNT (WITH CAPTIVE PANEL SCREWS)  
(6QDP-016-XX.X-TEU-XXX-5-F SHOWN)  
(SAME AS FIG 2, UNLESS OTHERWISE STATED)

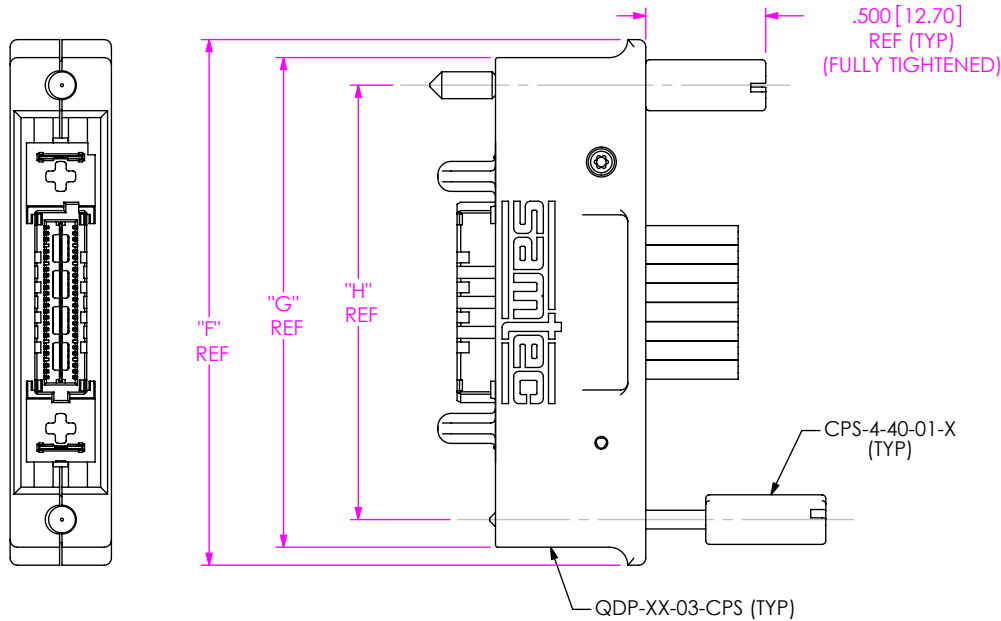

No. OF POSITIONS	"F"	"G"	"H"	QDP-XX-03-CPS
-016	2.181 [55.40]	2.033 [51.64]	1.810 [45.97]	QDP-01-03-CPS
-032	3.021 [76.73]	2.873 [72.97]	2.650 [67.31]	QDP-02-03-CPS
-048	3.861 [98.07]	3.713 [94.31]	3.490 [88.64]	QDP-03-03-CPS
-064	4.701 [119.41]	4.553 [115.65]	4.330 [109.98]	QDP-04-03-CPS

**FIG 4**  
DOUBLE VERTICAL (WITH SCREW DOWN OPTION)  
(6QDP-016-XX.X-STR-XXX-5-F SHOWN)  
(SAME AS FIG 1, UNLESS OTHERWISE STATED)

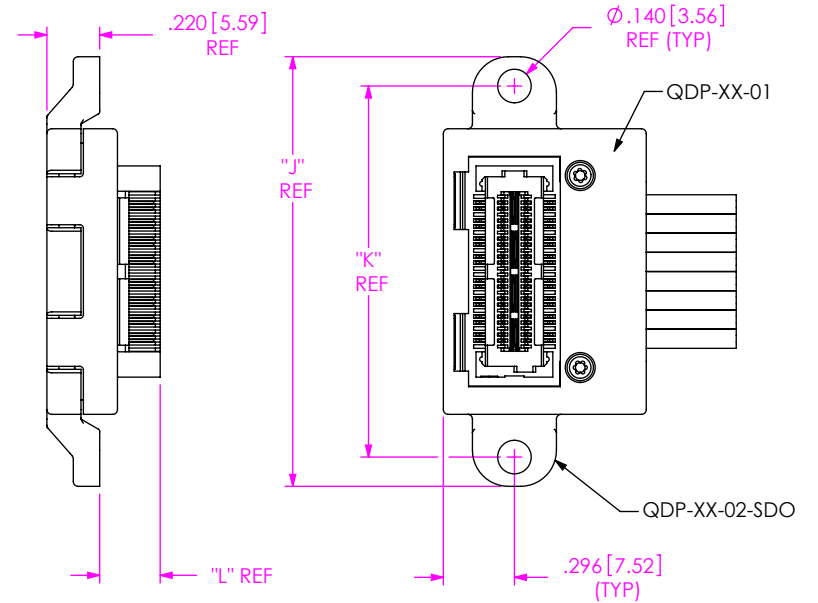

No. OF POSITIONS	"J"	"K"	QDP-XX-02-SDO
-016	1.790 [45.47]	1.546 [39.27]	QDP-01-02-SDO
-032	2.630 [66.80]	2.386 [60.60]	QDP-02-02-SDO
-048	3.470 [88.14]	3.226 [81.94]	QDP-03-02-SDO
-064	4.310 [109.47]	4.066 [103.28]	QDP-04-02-SDO

END	"L"
-TXX	0.224 [5.69]
-SXX	0.252 [6.40]

**FIG 5**  
(6QDP-016-XX.X-TEU-STL-N SHOWN)  
(SAME AS FIG 1, UNLESS OTHERWISE STATED)

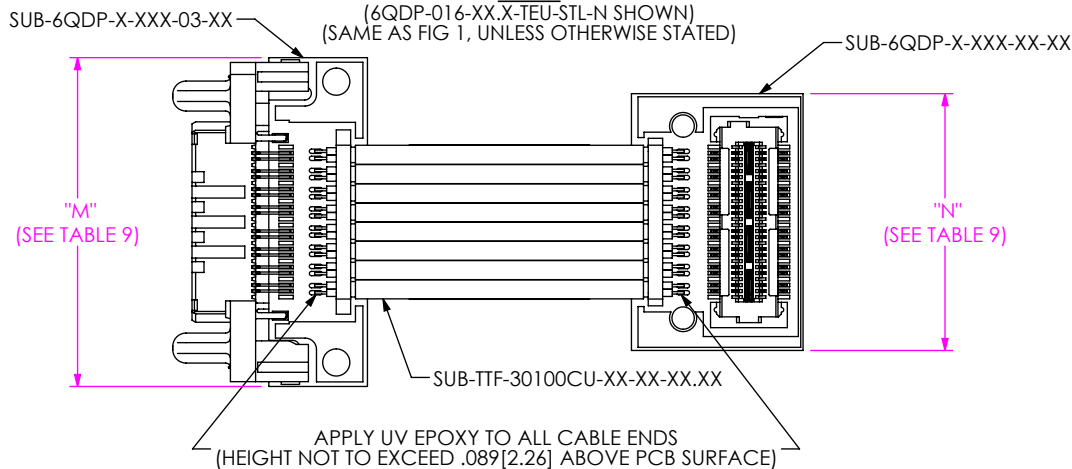

No. OF POSITIONS	"M"	"N"
-16	1.370 [34.80]	1.070 [27.18]
-32	2.210 [56.13]	1.910 [48.51]
-48	3.050 [77.47]	2.750 [69.85]
-64	3.890 [98.81]	3.590 [91.19]

**PROPRIETARY NOTE**  
THIS DOCUMENT CONTAINS CONFIDENTIAL AND PROPRIETARY INFORMATION AND ALL DESIGN, MANUFACTURING, REPRODUCTION, USE, PATENT RIGHTS AND SALES RIGHTS ARE EXPRESSLY RESERVED BY SAMTEC, INC. THIS DOCUMENT SHALL NOT BE DISCLOSED, IN WHOLE OR PART, TO ANY UNAUTHORIZED PERSON OR ENTITY NOR REPRODUCED, TRANSFERRED OR INCORPORATED IN ANY OTHER PROJECT IN ANY MANNER WITHOUT THE EXPRESS WRITTEN CONSENT OF SAMTEC, INC.

DO NOT SCALE DRAWING  
SHEET SCALE: 1:25:1



520 PARK EAST BLVD, NEW ALBANY, IN 47150  
PHONE: 812-944-6733 FAX: 812-948-5047  
e-Mail: info@SAMTEC.com code: 53322

DESCRIPTION:  
.635mm HIGH-SPEED TWIN-AX CABLE ASSEMBLY

DWG. NO.  
6QDP-XXX-XX.X-XXX-XXX-X-X

BY: T WHELAN 01/31/06 SHEET 5 OF 7



		TABLE 9													
FIRST END OPTION	FIRST END SUB-6QDP- X-XXX-XX-01	WIRING OPTION	FIRST END PIN #	SECOND END PIN #	WIRE #	SECOND END OPTION (SUB-6QDP-X-XXX-XX-XX)									
						-TTR	-TTL	-TBR	-TBL	-STR	-STL	-SBR	-SBL	-TEU	-TED
-TTR	-T-XXX-01-01	**_1	1	1	B1	-T-XXX-02-02	N/A	N/A	-T-XXX-01-02	N/A	-S-XXX-01-01	-S-XXX-02-01	N/A	N/A	-T-XXX-03-02
		**_2	1	2	B1	-T-XXX-02-01	N/A	N/A	-T-XXX-01-01	N/A	-S-XXX-01-02	-S-XXX-02-02	N/A	N/A	-T-XXX-03-01
		**_3	1	N-1	B1	N/A	-T-XXX-02-01	N/A	-S-XXX-02-02	N/A	N/A	-S-XXX-01-02	-T-XXX-03-01	N/A	N/A
		**_4	1	N	B1	N/A	-T-XXX-01-02	-T-XXX-02-02	N/A	-S-XXX-02-01	N/A	N/A	-S-XXX-01-01	-T-XXX-03-02	N/A
		-5	1	1	B1	-T-XXX-02-02	N/A	N/A	-T-XXX-01-02	N/A	-S-XXX-01-01	-S-XXX-02-01	N/A	N/A	-T-XXX-03-02
		-6	1	2	B1	-T-XXX-02-01	N/A	N/A	-T-XXX-01-01	N/A	-S-XXX-01-02	-S-XXX-02-02	N/A	N/A	-T-XXX-03-01
		-7	1	N-1	B1	N/A	-T-XXX-01-01	-T-XXX-02-01	N/A	-S-XXX-02-02	N/A	N/A	-S-XXX-01-02	-T-XXX-03-01	N/A
		-8	1	N	B1	N/A	-T-XXX-01-02	-T-XXX-02-02	N/A	-S-XXX-02-01	N/A	N/A	-S-XXX-01-01	-T-XXX-03-02	N/A
-TTL	-T-XXX-02-01	**_1	1	1	T16	N/A	-T-XXX-01-02	-T-XXX-02-02	N/A	-S-XXX-02-01	N/A	N/A	-S-XXX-01-01	-T-XXX-03-02	N/A
		**_2	1	2	T16	N/A	-T-XXX-01-01	-T-XXX-02-01	N/A	-S-XXX-02-02	N/A	N/A	-S-XXX-01-02	-T-XXX-03-01	N/A
		**_3	1	N-1	T16	-T-XXX-02-01	N/A	N/A	-T-XXX-01-01	N/A	-S-XXX-01-02	-S-XXX-02-02	N/A	N/A	-T-XXX-03-01
		**_4	1	N	T16	-T-XXX-02-02	N/A	N/A	-T-XXX-01-02	N/A	-S-XXX-01-01	-S-XXX-02-01	N/A	N/A	-T-XXX-03-02
		-5	1	1	T16	N/A	-T-XXX-01-02	-T-XXX-02-02	N/A	-S-XXX-02-01	N/A	N/A	-S-XXX-01-01	-T-XXX-03-02	N/A
		-6	1	2	T16	N/A	-T-XXX-01-01	-T-XXX-02-01	N/A	-S-XXX-02-02	N/A	N/A	-S-XXX-01-02	-T-XXX-03-01	N/A
		-7	1	N-1	T16	-T-XXX-02-01	N/A	N/A	-T-XXX-01-01	N/A	-S-XXX-01-02	-S-XXX-02-02	N/A	N/A	-T-XXX-03-01
		-8	1	N	T16	-T-XXX-02-02	N/A	N/A	-T-XXX-01-02	N/A	-S-XXX-01-01	-S-XXX-02-01	N/A	N/A	-T-XXX-03-02
-TBR	-T-XXX-01-01	**_1	1	1	T16	N/A	-T-XXX-01-02	-T-XXX-02-02	N/A	-S-XXX-02-01	N/A	N/A	-S-XXX-01-01	-T-XXX-03-02	N/A
		**_2	1	2	T16	N/A	-T-XXX-01-01	-T-XXX-02-01	N/A	-S-XXX-02-02	N/A	N/A	-S-XXX-01-02	-T-XXX-03-01	N/A
		**_3	1	N-1	T16	-T-XXX-02-01	N/A	N/A	-T-XXX-01-01	N/A	-S-XXX-01-02	-S-XXX-02-02	N/A	N/A	-T-XXX-03-01
		**_4	1	N	T16	-T-XXX-02-02	N/A	N/A	-T-XXX-01-02	N/A	-S-XXX-01-01	-S-XXX-02-01	N/A	N/A	-T-XXX-03-02
		-5	1	1	T16	N/A	-T-XXX-01-02	-T-XXX-02-02	N/A	-S-XXX-02-01	N/A	N/A	-S-XXX-01-01	-T-XXX-03-02	N/A
		-6	1	2	T16	N/A	-T-XXX-01-01	-T-XXX-02-01	N/A	-S-XXX-02-02	N/A	N/A	-S-XXX-01-02	-T-XXX-03-01	N/A
		-7	1	N-1	T16	-T-XXX-02-01	N/A	N/A	-T-XXX-01-01	N/A	-S-XXX-01-02	-S-XXX-02-02	N/A	N/A	-T-XXX-03-01
		-8	1	N	T16	-T-XXX-02-02	N/A	N/A	-T-XXX-01-02	N/A	-S-XXX-01-01	-S-XXX-02-01	N/A	N/A	-T-XXX-03-02
-TBL	-T-XXX-02-01	**_1	1	1	B1	-T-XXX-02-02	N/A	N/A	-T-XXX-01-02	N/A	-S-XXX-01-01	-S-XXX-02-01	N/A	N/A	-T-XXX-03-02
		**_2	1	2	B1	-T-XXX-02-01	N/A	N/A	-T-XXX-01-01	N/A	-S-XXX-01-02	-S-XXX-02-02	N/A	N/A	-T-XXX-03-01
		**_3	1	N-1	B1	N/A	-T-XXX-01-01	-T-XXX-02-01	N/A	-S-XXX-02-02	N/A	N/A	-S-XXX-01-02	-T-XXX-03-01	N/A
		**_4	1	N	B1	N/A	-T-XXX-01-02	-T-XXX-02-02	N/A	-S-XXX-02-01	N/A	N/A	-S-XXX-01-01	-T-XXX-03-02	N/A
		-5	1	1	B1	-T-XXX-02-02	N/A	N/A	-T-XXX-01-02	N/A	-S-XXX-01-01	-S-XXX-02-01	N/A	N/A	-T-XXX-03-02
		-6	1	2	B1	-T-XXX-02-01	N/A	N/A	-T-XXX-01-01	N/A	-S-XXX-01-02	-S-XXX-02-02	N/A	N/A	-T-XXX-03-01
		-7	1	N-1	B1	N/A	-T-XXX-01-01	-T-XXX-02-01	N/A	-S-XXX-02-02	N/A	N/A	-S-XXX-01-02	-T-XXX-03-01	N/A
		-8	1	N	B1	N/A	-T-XXX-01-02	-T-XXX-02-02	N/A	-S-XXX-02-01	N/A	N/A	-S-XXX-01-01	-T-XXX-03-02	N/A
-STR	-S-XXX-01-01	**_1	1	1	B16	N/A	-T-XXX-01-01	-T-XXX-02-01	N/A	-S-XXX-02-02	N/A	N/A	-S-XXX-01-02	-T-XXX-03-01	N/A
		**_2	1	2	B16	N/A	-T-XXX-01-02	-T-XXX-02-02	N/A	-S-XXX-02-01	N/A	N/A	-S-XXX-01-01	-T-XXX-03-02	N/A
		**_3	1	N-1	B16	-T-XXX-02-02	N/A	N/A	-T-XXX-01-02	N/A	-S-XXX-01-01	-S-XXX-02-01	N/A	N/A	-T-XXX-03-01
		**_4	1	N	B16	-T-XXX-02-01	N/A	N/A	-T-XXX-01-01	N/A	-S-XXX-01-02	-S-XXX-02-02	N/A	N/A	-T-XXX-03-01
		-5	1	1	B16	N/A	-T-XXX-01-01	-T-XXX-02-01	N/A	-S-XXX-02-02	N/A	N/A	-S-XXX-01-02	-T-XXX-03-01	N/A
		-6	1	2	B16	N/A	-T-XXX-01-02	-T-XXX-02-02	N/A	-S-XXX-02-01	N/A	N/A	-S-XXX-01-01	-T-XXX-03-02	N/A
		-7	1	N-1	B16	-T-XXX-02-02	N/A	N/A	-T-XXX-01-02	N/A	-S-XXX-01-01	-S-XXX-02-01	N/A	N/A	-T-XXX-03-01
		-8	1	N	B16	-T-XXX-02-01	N/A	N/A	-T-XXX-01-01	N/A	-S-XXX-01-02	-S-XXX-02-02	N/A	N/A	-T-XXX-03-01
-STL	-S-XXX-02-01	**_1	1	1	T1	-T-XXX-02-01	N/A	N/A	-T-XXX-01-01	N/A	-S-XXX-01-02	-S-XXX-02-02	N/A	N/A	-T-XXX-03-01
		**_2	1	2	T1	-T-XXX-02-02	N/A	N/A	-T-XXX-01-02	N/A	-S-XXX-01-01	-S-XXX-02-01	N/A	N/A	-T-XXX-03-02
		**_3	1	N-1	T1	N/A	-T-XXX-01-02	-T-XXX-02-02	N/A	-S-XXX-02-01	N/A	N/A	-S-XXX-01-01	-T-XXX-03-02	N/A
		**_4	1	N	T1	N/A	-T-XXX-01-01	-T-XXX-02-01	N/A	-S-XXX-02-02	N/A	N/A	-S-XXX-01-02	-T-XXX-03-01	N/A
		-5	1	1	T1	-T-XXX-02-01	N/A	N/A	-T-XXX-01-01	N/A	-S-XXX-01-02	-S-XXX-02-02	N/A	N/A	-T-XXX-03-01
		-6	1	2	T1	-T-XXX-02-02	N/A	N/A	-T-XXX-01-02	N/A	-S-XXX-01-01	-S-XXX-02-01	N/A	N/A	-T-XXX-03-02
		-7	1	N-1	T1	N/A	-T-XXX-01-02	-T-XXX-02-02	N/A	-S-XXX-02-01	N/A	N/A	-S-XXX-01-01	-T-XXX-03-02	N/A
		-8	1	N	T1	N/A	-T-XXX-01-01	-T-XXX-02-01	N/A	-S-XXX-02-02	N/A	N/A	-S-XXX-01-02	-T-XXX-03-01	N/A

\*\* : AVAILABLE TO EXISTING CUSTOMERS ONLY

**PROPRIETARY NOTE**  
 THIS DOCUMENT CONTAINS CONFIDENTIAL AND PROPRIETARY INFORMATION AND ALL DESIGN, MANUFACTURING, REPRODUCTION, USE, PATENT RIGHTS AND SALES RIGHTS ARE EXPRESSLY RESERVED BY SAMTEC, INC. THIS DOCUMENT SHALL NOT BE DISCLOSED, IN WHOLE OR PART, TO ANY UNAUTHORIZED PERSON OR ENTITY NOR REPRODUCED, TRANSFERRED OR INCORPORATED IN ANY OTHER PROJECT IN ANY MANNER WITHOUT THE EXPRESS WRITTEN CONSENT OF SAMTEC, INC.

DO NOT SCALE DRAWING  
 SHEET SCALE: 1:25:1



520 PARK EAST BLVD, NEW ALBANY, IN 47150  
 PHONE: 812-944-6733 FAX: 812-948-5047  
 e-Mail: info@SAMTEC.com code: 55322

DESCRIPTION:  
 .635mm HIGH-SPEED TWIN-AX CABLE ASSEMBLY  
 DWG. NO.  
**6QDP-XXX-XX.X-XXX-XXX-X-X**  
 BY: T WHELAN 01/31/06 SHEET 6 OF 7

TABLE 9 (CONT)

FIRST END OPTION	FIRST END SUB-6QDP-XXX-XX-01	WIRING OPTION	FIRST END PIN #	SECOND END PIN #	WIRE #	SECOND END OPTION (SUB-6QDP-X-XXX-XX-XX)									
						-TTR	-TTL	-TBR	-TBL	-STR	-STL	-SBR	-SBL	-TEU	-TED
-SBR	-S-XXX-01-01	**_1	1	1	T1	-T-XXX-02-01	N/A	N/A	-T-XXX-01-01	N/A	-S-XXX-01-02	-S-XXX-02-02	N/A	N/A	-T-XXX-03-01
		**_2	1	2	T1	-T-XXX-02-02	N/A	N/A	-T-XXX-01-02	N/A	-S-XXX-01-01	-S-XXX-02-01	N/A	N/A	-T-XXX-03-02
		**_3	1	N-1	T1	N/A	-T-XXX-01-02	-T-XXX-02-02	N/A	-S-XXX-02-01	N/A	N/A	-S-XXX-01-01	-T-XXX-03-02	N/A
		**_4	1	N	T1	N/A	-T-XXX-01-01	-T-XXX-02-01	N/A	-S-XXX-02-02	N/A	N/A	-S-XXX-01-02	-T-XXX-03-01	N/A
		-5	1	1	T1	-T-XXX-02-01	N/A	N/A	-T-XXX-01-01	N/A	-S-XXX-01-02	-S-XXX-02-02	N/A	N/A	-T-XXX-03-01
		-6	1	2	T1	-T-XXX-02-02	N/A	N/A	-T-XXX-01-02	N/A	-S-XXX-01-01	-S-XXX-02-01	N/A	N/A	-T-XXX-03-02
		-7	1	N-1	T1	N/A	-T-XXX-01-02	-T-XXX-02-02	N/A	-S-XXX-02-01	N/A	N/A	-S-XXX-01-01	-T-XXX-03-02	N/A
		-8	1	N	T1	N/A	-T-XXX-01-01	-T-XXX-02-01	N/A	-S-XXX-02-02	N/A	N/A	-S-XXX-01-02	-T-XXX-03-01	N/A
-SBL	-S-XXX-02-01	**_1	1	1	B16	N/A	-T-XXX-01-01	-T-XXX-02-01	N/A	-S-XXX-02-02	N/A	N/A	-S-XXX-01-02	-T-XXX-03-01	N/A
		**_2	1	2	B16	N/A	-T-XXX-01-02	-T-XXX-02-02	N/A	-S-XXX-02-01	N/A	N/A	-S-XXX-01-01	-T-XXX-03-02	N/A
		**_3	1	N-1	B16	-T-XXX-02-02	N/A	N/A	-T-XXX-01-02	N/A	-S-XXX-01-01	-S-XXX-02-01	N/A	N/A	-T-XXX-03-02
		**_4	1	N	B16	-T-XXX-02-01	N/A	N/A	-T-XXX-01-01	N/A	-S-XXX-01-02	-S-XXX-02-02	N/A	N/A	-T-XXX-03-01
		-5	1	1	B16	N/A	-T-XXX-01-01	-T-XXX-02-01	N/A	-S-XXX-02-02	N/A	N/A	-S-XXX-01-02	-T-XXX-03-01	N/A
		-6	1	2	B16	N/A	-T-XXX-01-02	-T-XXX-02-02	N/A	-S-XXX-02-01	N/A	N/A	-S-XXX-01-01	-T-XXX-03-02	N/A
		-7	1	N-1	B16	-T-XXX-02-02	N/A	N/A	-T-XXX-01-02	N/A	-S-XXX-01-01	-S-XXX-02-01	N/A	N/A	-T-XXX-03-02
		-8	1	N	B16	-T-XXX-02-01	N/A	N/A	-T-XXX-01-01	N/A	-S-XXX-01-02	-S-XXX-02-02	N/A	N/A	-T-XXX-03-01
-TEU	-T-XXX-03-01	**_1	1	1	B1	-T-XXX-02-02	N/A	N/A	-T-XXX-01-02	N/A	-S-XXX-01-01	-S-XXX-02-01	N/A	N/A	-T-XXX-03-02
		**_2	1	2	B1	-T-XXX-02-01	N/A	N/A	-T-XXX-01-01	N/A	-S-XXX-01-02	-S-XXX-02-02	N/A	N/A	-T-XXX-03-01
		**_3	1	N-1	B1	N/A	-T-XXX-01-01	-T-XXX-02-01	N/A	-S-XXX-02-02	N/A	N/A	-S-XXX-01-02	-T-XXX-03-01	N/A
		**_4	1	N	B1	N/A	-T-XXX-01-02	-T-XXX-02-02	N/A	-S-XXX-02-01	N/A	N/A	-S-XXX-01-01	-T-XXX-03-02	N/A
		-5	1	1	B1	-T-XXX-02-02	N/A	N/A	-T-XXX-01-02	N/A	-S-XXX-01-01	-S-XXX-02-01	N/A	N/A	-T-XXX-03-02
		-6	1	2	B1	-T-XXX-02-01	N/A	N/A	-T-XXX-01-01	N/A	-S-XXX-01-02	-S-XXX-02-02	N/A	N/A	-T-XXX-03-01
		-7	1	N-1	B1	N/A	-T-XXX-01-01	-T-XXX-02-01	N/A	-S-XXX-02-02	N/A	N/A	-S-XXX-01-02	-T-XXX-03-01	N/A
		-8	1	N	B1	N/A	-T-XXX-01-02	-T-XXX-02-02	N/A	-S-XXX-02-01	N/A	N/A	-S-XXX-01-01	-T-XXX-03-02	N/A
-TED	-T-XXX-03-01	**_1	1	1	T16	N/A	-T-XXX-01-02	-T-XXX-02-02	N/A	-S-XXX-02-01	N/A	N/A	-S-XXX-01-01	-T-XXX-03-02	N/A
		**_2	1	2	T16	N/A	-T-XXX-01-01	-T-XXX-02-01	N/A	-S-XXX-02-02	N/A	N/A	-S-XXX-01-02	-T-XXX-03-01	N/A
		**_3	1	N-1	T16	-T-XXX-02-01	N/A	N/A	-T-XXX-01-01	N/A	-S-XXX-01-02	-S-XXX-02-02	N/A	N/A	-T-XXX-03-01
		**_4	1	N	T16	-T-XXX-02-02	N/A	N/A	-T-XXX-01-02	N/A	-S-XXX-01-01	-S-XXX-02-01	N/A	N/A	-T-XXX-03-02
		-5	1	1	T16	N/A	-T-XXX-01-02	-T-XXX-02-02	N/A	-S-XXX-02-01	N/A	N/A	-S-XXX-01-01	-T-XXX-03-02	N/A
		-6	1	2	T16	N/A	-T-XXX-01-01	-T-XXX-02-01	N/A	-S-XXX-02-02	N/A	N/A	-S-XXX-01-02	-T-XXX-03-01	N/A
		-7	1	N-1	T16	-T-XXX-02-01	N/A	N/A	-T-XXX-01-01	N/A	-S-XXX-01-02	-S-XXX-02-02	N/A	N/A	-T-XXX-03-01
		-8	1	N	T16	-T-XXX-02-02	N/A	N/A	-T-XXX-01-02	N/A	-S-XXX-01-01	-S-XXX-02-01	N/A	N/A	-T-XXX-03-02

\*\* : AVAILABLE TO EXISTING CUSTOMERS ONLY

**PROPRIETARY NOTE**  
 THIS DOCUMENT CONTAINS CONFIDENTIAL AND PROPRIETARY INFORMATION AND ALL DESIGN, MANUFACTURING, REPRODUCTION, USE, PATENT RIGHTS AND SALES RIGHTS ARE EXPRESSLY RESERVED BY SAMTEC, INC. THIS DOCUMENT SHALL NOT BE DISCLOSED, IN WHOLE OR PART, TO ANY UNAUTHORIZED PERSON OR ENTITY NOR REPRODUCED, TRANSFERRED OR INCORPORATED IN ANY OTHER PROJECT IN ANY MANNER WITHOUT THE EXPRESS WRITTEN CONSENT OF SAMTEC, INC.



520 PARK EAST BLVD, NEW ALBANY, IN 47150  
 PHONE: 812-944-6733 FAX: 812-948-5047  
 e-Mail: info@SAMTEC.com code: 55322

DO NOT SCALE DRAWING

SHEET SCALE: 1:25:1

DESCRIPTION:  
 .635mm HIGH-SPEED TWIN-AX CABLE ASSEMBLY

DWG. NO.  
**6QDP-XXX-XX.X-XXX-XXX-X-X**

BY: T WHELAN 01/31/06 SHEET 7 OF 7