



Rosenberger
Handling precautions

- Keep connectors clean.
- Connect calibration standards only to test and not other devices that have been checked for gauge.
- Do not touch the contact of the contact

Rosenberger

Standard	T thru (0)	Loose (0)	Open (0)	Unit	Short (0)	Unit
Min. Freq.	0	0	0	GHz	0	GHz
Max. Freq.	1	1	1	GHz	1	GHz
Offset Coef. Ca	30	30	30	dB	30	dB
Offset Coef. Cb	208.611	208.611	208.611	dB	208.611	dB
Offset Loss	2.31	2.31	2.31	dB	2.31	dB
Cl / L1	0	0	0	ps	0	ps
Cs / L2	0	0	0	ps	0	ps
Cs / L3	0	0	0	ps	0	ps
Cs / L4	0	0	0	ps	0	ps
Cs / L5	0	0	0	ps	0	ps
Cs / L6	0	0	0	ps	0	ps
Cs / L7	0	0	0	ps	0	ps
Cs / L8	0	0	0	ps	0	ps
Cs / L9	0	0	0	ps	0	ps
Cs / L10	0	0	0	ps	0	ps
Cs / L11	0	0	0	ps	0	ps
Cs / L12	0	0	0	ps	0	ps
Cs / L13	0	0	0	ps	0	ps
Cs / L14	0	0	0	ps	0	ps
Cs / L15	0	0	0	ps	0	ps
Cs / L16	0	0	0	ps	0	ps
Cs / L17	0	0	0	ps	0	ps
Cs / L18	0	0	0	ps	0	ps
Cs / L19	0	0	0	ps	0	ps
Cs / L20	0	0	0	ps	0	ps
Cs / L21	0	0	0	ps	0	ps
Cs / L22	0	0	0	ps	0	ps
Cs / L23	0	0	0	ps	0	ps
Cs / L24	0	0	0	ps	0	ps
Cs / L25	0	0	0	ps	0	ps
Cs / L26	0	0	0	ps	0	ps
Cs / L27	0	0	0	ps	0	ps
Cs / L28	0	0	0	ps	0	ps
Cs / L29	0	0	0	ps	0	ps
Cs / L30	0	0	0	ps	0	ps
Cs / L31	0	0	0	ps	0	ps
Cs / L32	0	0	0	ps	0	ps
Cs / L33	0	0	0	ps	0	ps
Cs / L34	0	0	0	ps	0	ps
Cs / L35	0	0	0	ps	0	ps
Cs / L36	0	0	0	ps	0	ps
Cs / L37	0	0	0	ps	0	ps
Cs / L38	0	0	0	ps	0	ps
Cs / L39	0	0	0	ps	0	ps
Cs / L40	0	0	0	ps	0	ps
Cs / L41	0	0	0	ps	0	ps
Cs / L42	0	0	0	ps	0	ps
Cs / L43	0	0	0	ps	0	ps
Cs / L44	0	0	0	ps	0	ps
Cs / L45	0	0	0	ps	0	ps
Cs / L46	0	0	0	ps	0	ps
Cs / L47	0	0	0	ps	0	ps
Cs / L48	0	0	0	ps	0	ps
Cs / L49	0	0	0	ps	0	ps
Cs / L50	0	0	0	ps	0	ps
Cs / L51	0	0	0	ps	0	ps
Cs / L52	0	0	0	ps	0	ps
Cs / L53	0	0	0	ps	0	ps
Cs / L54	0	0	0	ps	0	ps
Cs / L55	0	0	0	ps	0	ps
Cs / L56	0	0	0	ps	0	ps
Cs / L57	0	0	0	ps	0	ps
Cs / L58	0	0	0	ps	0	ps
Cs / L59	0	0	0	ps	0	ps
Cs / L60	0	0	0	ps	0	ps
Cs / L61	0	0	0	ps	0	ps
Cs / L62	0	0	0	ps	0	ps
Cs / L63	0	0	0	ps	0	ps
Cs / L64	0	0	0	ps	0	ps
Cs / L65	0	0	0	ps	0	ps
Cs / L66	0	0	0	ps	0	ps
Cs / L67	0	0	0	ps	0	ps
Cs / L68	0	0	0	ps	0	ps
Cs / L69	0	0	0	ps	0	ps
Cs / L70	0	0	0	ps	0	ps
Cs / L71	0	0	0	ps	0	ps
Cs / L72	0	0	0	ps	0	ps
Cs / L73	0	0	0	ps	0	ps
Cs / L74	0	0	0	ps	0	ps
Cs / L75	0	0	0	ps	0	ps
Cs / L76	0	0	0	ps	0	ps
Cs / L77	0	0	0	ps	0	ps
Cs / L78	0	0	0	ps	0	ps
Cs / L79	0	0	0	ps	0	ps
Cs / L80	0	0	0	ps	0	ps
Cs / L81	0	0	0	ps	0	ps
Cs / L82	0	0	0	ps	0	ps
Cs / L83	0	0	0	ps	0	ps
Cs / L84	0	0	0	ps	0	ps
Cs / L85	0	0	0	ps	0	ps
Cs / L86	0	0	0	ps	0	ps
Cs / L87	0	0	0	ps	0	ps
Cs / L88	0	0	0	ps	0	ps
Cs / L89	0	0	0	ps	0	ps
Cs / L90	0	0	0	ps	0	ps
Cs / L91	0	0	0	ps	0	ps
Cs / L92	0	0	0	ps	0	ps
Cs / L93	0	0	0	ps	0	ps
Cs / L94	0	0	0	ps	0	ps
Cs / L95	0	0	0	ps	0	ps
Cs / L96	0	0	0	ps	0	ps
Cs / L97	0	0	0	ps	0	ps
Cs / L98	0	0	0	ps	0	ps
Cs / L99	0	0	0	ps	0	ps
Cs / L100	0	0	0	ps	0	ps

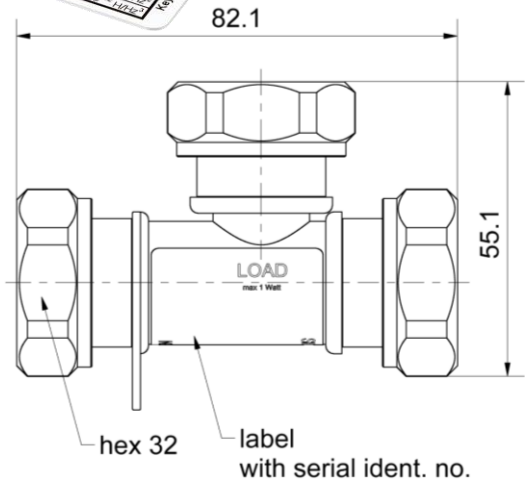

All dimensions are in mm; tolerances according to ISO 2768 m-H

Interface
According to

IEC 61169-4, EN 122190, DIN 47223

Contents and Documentation
This kit is delivered with

- **Standard Definitions Card**
Printed Standard Definitions that can be used on nearly all Vector Network Analyzers
- **Certificate of Testing**
- **Lanyard**
- **Hard Shell Case**
- **Protection Caps**
- **User Manual**

Material and plating

Connector parts
Center conductor
Outer conductor
Body
Coupling nut
Dielectric
Substrate

Material
Brass
Brass
Brass
Brass
PP
Al₂O₃

Plating
Gold, min. 1.27 µm, over nickel
Flash white bronze over silver(e.g. Optargen®)
powder coated
Flash white bronze over silver(e.g. Optargen®)

Dieses Dokument ist urheberrechtlich geschützt • This document is protected by copyright • Rosenberger Hochfrequenztechnik GmbH & Co. KG RFB00035/12.20/6.4

Electrical data

Frequency range DC to 6 GHz

Open

Return loss ≤ 0.15 dB, DC to 6 GHz
Error from nominal phase¹ $\leq 3.0^\circ$, DC to 6 GHz

Short

Return loss ≤ 0.15 dB, DC to 6 GHz
Error from nominal phase² $\leq 3.0^\circ$, DC to 6 GHz

Load

Return loss ≥ 40 dB, DC to 2.5 GHz
 ≥ 38 dB, 2.5 GHz to 6 GHz
DC-Resistance $50 \Omega \pm 0.5 \Omega$
Power handling (at 25 °C, sea level) ≤ 1.0 W, derate by 0.01 W/K

¹ The nominal phase is defined by the Offset Delay, the Offset Loss and the Fringing Capacitances

² The nominal phase is defined by the Offset Delay, the Offset Loss and the Short Inductance

Mechanical data

Mating cycles ≥ 500
Maximum torque 30 Nm
Recommended torque 2.26 Nm
Gauge 1.47 mm to 1.77 mm

General standard definitions

For proper operation the vector network analyzer (VNA) needs a model describing the electrical behaviour of this calibration standard. The different models, units, and terms used will depend on the VNA type and they will have to be entered into the VNA. All values are based on typical geometry and plating.

Open

Offset Z_0 / Impedance / Z_0 50 Ω
Offset Delay 56.372 ps
Length (electrical) / Offset Length 16.90 mm
Offset Loss 0.50 G Ω /s
Loss 0.0049 dB/ $\sqrt{\text{GHz}}$
Fringing Capacitances $C_0 = 168.000 \times 10^{-15}$ F / 168.000 fF
 $C_1 = 2600.00 \times 10^{-27}$ F/Hz / 2.60000 fF /GHz
 $C_2 = 50.0000 \times 10^{-36}$ F/Hz² / 0.05000 fF /GHz²
 $C_3 = 0.80000 \times 10^{-45}$ F/Hz³ / 0.00080 fF /GHz³

Short

Offset Z_0 / Impedance / Z_0	50 Ω		
Offset Delay	65.712 ps		
Length (electrical) / Offset Length	19.70 mm		
Offset Loss	0.50 G Ω /s		
Loss	0.0057 dB/ $\sqrt{\text{GHz}}$		
Short Inductance	$L_0 = 0.0000 \times 10^{-12}$ H	/	0.0000 pH
	$L_1 = 0.0000 \times 10^{-24}$ H/Hz	/	0.0000 pH/GHz
	$L_2 = 0.0000 \times 10^{-33}$ H/Hz ²	/	0.0000 pH/GHz ²
	$L_3 = 0.0000 \times 10^{-42}$ H/Hz ³	/	0.0000 pH/GHz ³

Load

Offset Z_0 / Impedance / Z_0	50 Ω
Offset Delay	0.0000 ps
Length (electrical) / Offset Length	0.000 mm
Offset Loss	0.00 G Ω /s
Loss	0.0000 dB/ $\sqrt{\text{GHz}}$

Environmental data

Operating temperature range ³	0 °C to +50 °C
Storage temperature range	- 55 °C to +90 °C
RoHS	compliant

³ Temperature range over which these specifications are valid.

Declaration of documentation

Standard delivery for this kit includes Test Results. The documentation issued reports which quantities were tested individually, traceable to national / international standards. Model based standard definitions of the calibration standards are reported in Agilent / Keysight, Rohde & Schwarz and Anritsu compatible VNA format.

Inspection interval

Recommendation	12 months
----------------	-----------

Packing

Weight	332 g/pce
--------	-----------

While the information has been carefully compiled to the best of our knowledge, nothing is intended as representation or warranty on our part and no statement herein shall be construed as recommendation to infringe existing patents. In the effort to improve our products, we reserve the right to make changes judged to be necessary.

For the installation of the electrotechnical equipment, particular electrotechnical expertise is required.



Draft	Date	Approved	Date	Rev.	Engineering change number	Name	Date
Kerstin Herzog	10.07.06	Lars Ramtke	30.05.23	I00	23-0004	Marion Striegler	25.05.23

Rosenberger Hochfrequenztechnik GmbH & Co. KG P.O.Box 1260 D-84526 Tittmoning Germany www.rosenberger.com				Tel. : +49 8684 18-0 Email : info@rosenberger.com		Page 3 / 3	
--	--	--	--	--	--	---------------	--