

REVISIONS

REV.	DESCRIPTION	DATE	APPROVED
A	INITIAL RELEASE	05/03/18	D.N.

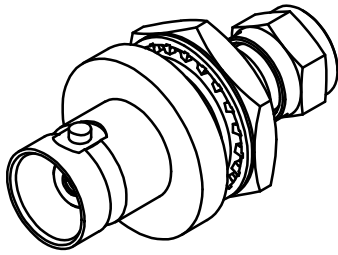

**PANEL CUT OUT**

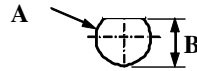

inches		
	Maxi	mini
<b>A</b>	<b>.505</b>	<b>.509</b>
<b>B</b>	<b>.471</b>	<b>.475</b>

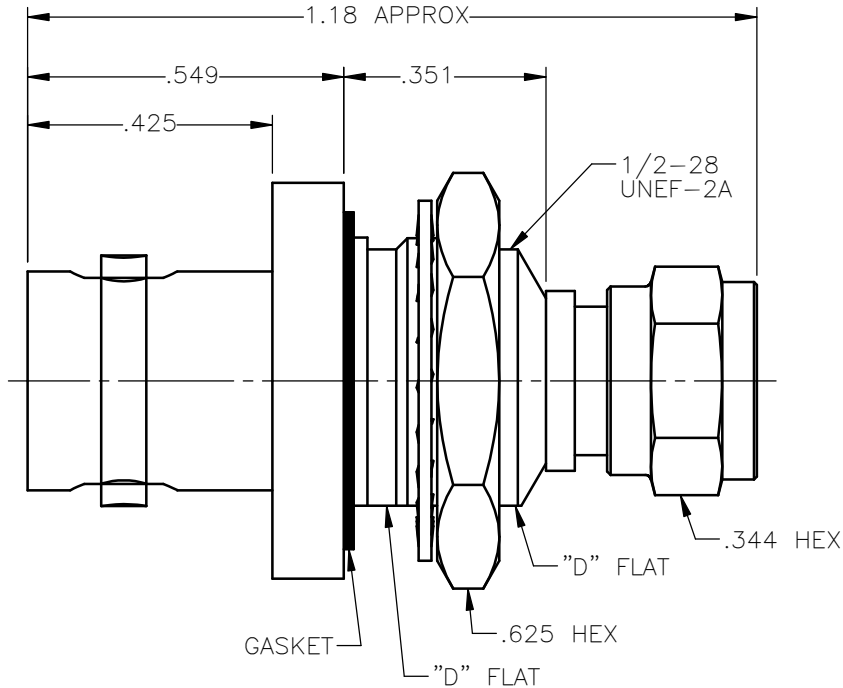

NOTES:

MATERIALS:

1. INSULATORS = VIRGIN WHITE TEFLON PER ASTM D1710, GRADE 1, TYPE I, CLASS "B".
2. CONTACTS = BERYLLIUM COPPER PER ASTM B196, ALLOY C17300, TEMPER TD04.
3. GASKET = SILICONE RUBBER 45-55 DUROMETER DOW CORNING SILASTIC 250.
4. LOCKWASHER = PHOSPHOR BRONZE PER ASTM B139, COPPER ALLOY C53400, TEMPER H04.
5. ALL OTHER METAL PARTS = BRASS PER ASTM B16, ALLOY C36000, TEMPER H02.

FINISHES:

1. CONTACTS = GOLD PLATE PER ASTM B488-11, TYPE II, 50µin MIN, GRADE C, OVER 100 TO 200µin STRESS FREE SULFAMATE NICKEL PER AMS-QQ-N-290.
2. ALL OTHER METAL PARTS = GOLD PLATE PER ASTM B488-11, TYPE II, 30µin MIN, GRADE C OVER 100 TO 200µin COPPER STRIKE PER AMS 2418.

UNLESS OTHERWISE SPECIFIED DIMENSIONS ARE IN INCHES TOLERANCES ON

DWN:	DATE
D.N.	05/03/18
CHKD:	DATE
C.E.	05/03/18
APVD:	DATE
J.M.	05/03/18



Property of Radiall  
This document cannot be reproduced or communicated to a third party without prior written permission of RADIALL.



BNC STRAIGHT JACK BULKHEAD FRONT MOUNT TO 75 OHM SCREW-ON FEMALE PLUG

REFERENCE:

ORIGINATED: D.N.  
DATE: 05/03/18

MATERIALS & FINISHES:

SEE NOTES

SIZE	FSCM NO.	DWG NO.	REV
A	19505	5515-1501-000	A
SCALE	THIRD ANGLE PROJECTION		SHEET 1 OF 1
3:1			

5515-1501-000