



Figure similar

Duplex starter w/ alternator, Size 3 1/2, Three phase full voltage, Amb compensate bimetal OLrelay Contactor amp rating 115Amp 110V 50HZ / 120V 60HZ coil, Non-combination type, Enclosure NEMA type 12, Dust/drip proof for indoors

product brand name	Class 83
design of the product	Duplex controller with alternator
special product feature	Half-size controller
General technical data	
weight [lb]	93 lb
Height x Width x Depth [in]	29 × 23 × 9 in
touch protection against electrical shock	NA for enclosed products
installation altitude [ft] at height above sea level maximum	6560 ft
ambient temperature [°F]	
• during storage	-22 ... +149 °F
• during operation	-4 ... +104 °F
ambient temperature	
• during storage	-30 ... +65 °C
• during operation	-20 ... +40 °C
country of origin	USA
Horsepower ratings	
yielded mechanical performance [hp] for 3-phase AC motor	
• at 200/208 V rated value	30 hp
• at 220/230 V rated value	40 hp
• at 460/480 V rated value	75 hp
• at 575/600 V rated value	75 hp
Contactors	
size of contactor	Controller half size 3 1/2
number of NO contacts for main contacts	3
operating voltage for main current circuit at AC at 60 Hz maximum	600 V
operational current at AC at 600 V rated value	115 A
mechanical service life (switching cycles) of the main contacts typical	5000000
Auxiliary contact	
number of NC contacts at contactor for auxiliary contacts	0
number of NO contacts at contactor for auxiliary contacts	1
number of total auxiliary contacts maximum	7
contact rating of auxiliary contacts of contactor according to UL	10A@600VAC (A600), 5A@600VDC (P600)
Coil	

type of voltage of the control supply voltage	AC
control supply voltage	
• at DC rated value	0 ... 0 V
• at AC at 50 Hz rated value	110 ... 110 V
• at AC at 60 Hz rated value	120 ... 120 V
holding power at AC minimum	14 W
apparent pick-up power of magnet coil at AC	310 V·A
apparent holding power of magnet coil at AC	26 V·A
operating range factor control supply voltage rated value of magnet coil	0.85 ... 1.1
percental drop-out voltage of magnet coil related to the input voltage	50 %
switch ON delay time	26 ... 41 ms
OFF delay time	14 ... 19 ms
Overload relay	
product function	
• overload protection	Yes
• test function	Yes
• external reset	Yes
reset function	Manual and automatic
adjustment range of thermal overload trip unit	0.85 ... 1.15
number of NC contacts of auxiliary contacts of overload relay	3
number of NO contacts of auxiliary contacts of overload relay	0
operational current of auxiliary contacts of overload relay	
• at AC at 600 V	5 A
• at DC at 250 V	5 A
contact rating of auxiliary contacts of overload relay according to UL	5A@600VAC (B600), 5A@250VDC (P300)
Enclosure	
degree of protection NEMA rating of the enclosure	NEMA 12 enclosure
design of the housing	Dust tight and drip proof for indoors
Mounting/wiring	
mounting position	Vertical
fastening method	Surface mounting and installation
type of electrical connection for supply voltage line-side	Box lug
tightening torque [lbf·in] for supply	120 ... 120 lbf·in
type of connectable conductor cross-sections at line-side at AWG cables single or multi-stranded	1x (14 ... 2/0 AWG)
temperature of the conductor for supply maximum permissible	75 °C
material of the conductor for supply	AL or CU
type of electrical connection for load-side outgoing feeder	Screw-type terminals
tightening torque [lbf·in] for load-side outgoing feeder	35 ... 50 lbf·in
type of electrical connection of magnet coil	Screw-type terminals
tightening torque [lbf·in] at magnet coil	5 ... 12 lbf·in
type of connectable conductor cross-sections of magnet coil at AWG cables single or multi-stranded	2x (16 ... 12 AWG)
temperature of the conductor at magnet coil maximum permissible	75 °C
material of the conductor at magnet coil	CU
type of electrical connection at contactor for auxiliary contacts	Screw-type terminals
tightening torque [lbf·in] at contactor for auxiliary contacts	10 ... 15 lbf·in
type of connectable conductor cross-sections at contactor at AWG cables for auxiliary contacts single or multi-stranded	1x (12 AWG), 2x (16 ... 14 AWG), 2x (18 ... 16 AWG)
temperature of the conductor at contactor for auxiliary contacts maximum permissible	75 °C
material of the conductor at contactor for auxiliary contacts	CU

type of electrical connection at overload relay for auxiliary contacts	Screw-type terminals
tightening torque [lbf-in] at overload relay for auxiliary contacts	5 ... 12 lbf-in
type of connectable conductor cross-sections at overload relay at AWG cables for auxiliary contacts single or multi-stranded	2x (16 ... 12 AWG)
temperature of the conductor at overload relay for auxiliary contacts maximum permissible	75 °C
material of the conductor at overload relay for auxiliary contacts	CU

Short-circuit current rating

design of the fuse link for short-circuit protection of the main circuit required	10kA@600V (Class H or K); 100kA@600V (Class R or J)
design of the short-circuit trip	Thermal magnetic circuit breaker
breaking capacity maximum short-circuit current (Icu) <ul style="list-style-type: none"> • at 240 V • at 480 V • at 600 V 	14 kA 10 kA 10 kA
certificate of suitability	NEMA ICS 2; UL 508; CSA 22.2, No.14

Further information

Industrial Controls - Product Overview (Catalogs, Brochures,...)

www.usa.siemens.com/iccatalog

Industry Mall (Online ordering system)

<https://mall.industry.siemens.com/mall/en/us/Catalog/product?mlfb=US2:83IP920F81>

Service&Support (Manuals, Certificates, Characteristics, FAQs,...)

<https://support.industry.siemens.com/cs/US/en/ps/US2:83IP920F81>

Image database (product images, 2D dimension drawings, 3D models, device circuit diagrams, EPLAN macros, ...)

http://www.automation.siemens.com/bilddb/cax_de.aspx?mlfb=US2:83IP920F81&lang=en

Certificates/approvals

<https://support.industry.siemens.com/cs/US/en/ps/US2:83IP920F81/certificate>

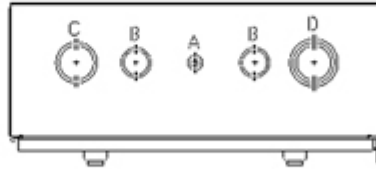
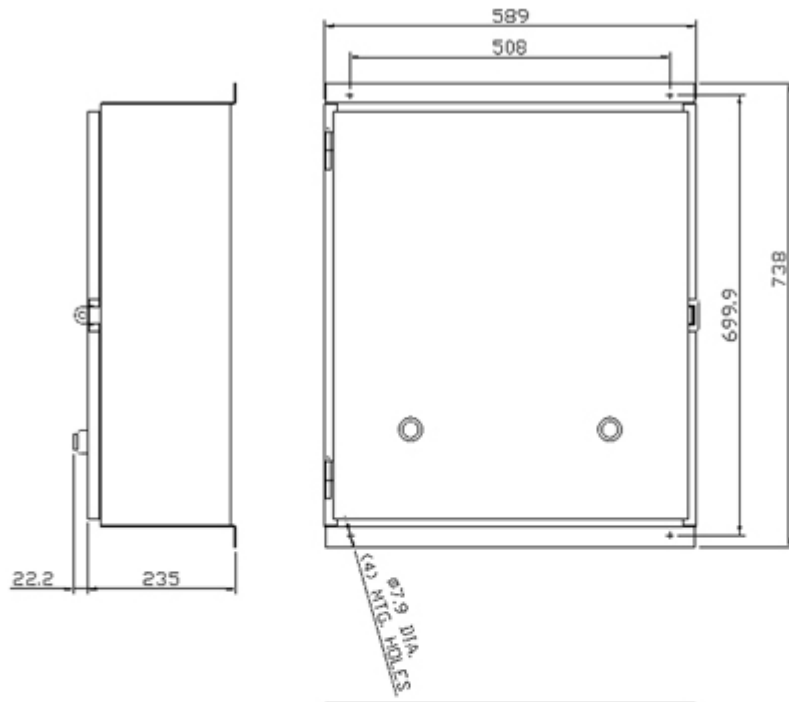

CONDUITS TYP. TOP & BOTTOM

LETTER	CONDUIT SIZE
A	Ø12.7 & Ø19 DIA. CONDUIT
B	Ø31.8 & Ø38.1 DIA. CONDUIT
C	Ø50.8 & Ø63.5 DIA. CONDUIT
D	Ø50.8, Ø63.5 & Ø76.2 DIA. CONDUIT

SCHEMATIC DIAGRAM

Class 83 & 84 Duplex W/Auto Alternation Size 0-4

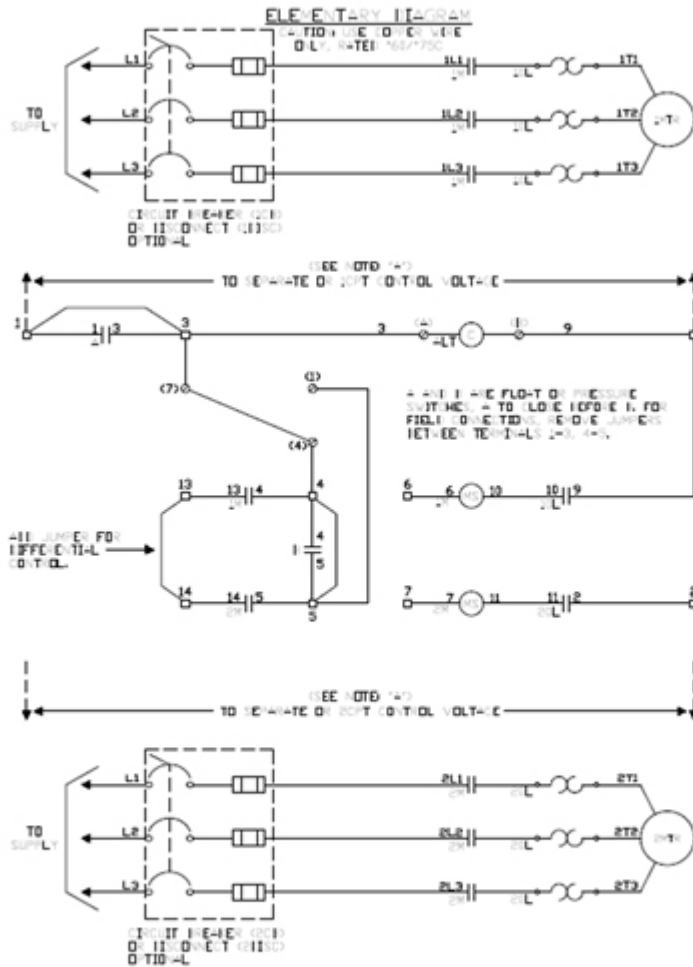

- NOTES:**
- A. FOR SEPARATE OR SHUT OFF OIL VOLTAGE (OR DS) CONNECTION, LETTER L1, L2, L3 AND R1, R2, R3 SHOULD BE FACTOR IN FIELD DISTRIBUTION.
 - B. FOR PROTECTION OF TERMINAL OIL CIRCUIT INDUCTIONS IN ACCORDANCE WITH THE N.E.C., USE FUSE 1/2 AMPERE.
 - C. TO USE THIS CONTROLLER W/O SWITCHEL JUMPER BETWEEN THE FOLLOWING PAIRS OF TERMINALS (1-3, 4-5, 6-7, 8-9, 10-11, 12-13).
 - D. FOR T.O. OILTOGGLE TO SWITCHEL WIRE AS SHOWN AND ALL JUMPER BETWEEN TERMINALS 9-10.
 - E. SEPARATE TOGGLE CONNECTIONS TO TERMINALS 8 AND 12 ARE REQUIRED ONLY WHEN THREE POSITION SELECTOR SWITCH IS INSTALLED.

last modified:

3/11/2020