

AVAILABLE BY SPECIAL ORDER- NAFTA REGION ONLY

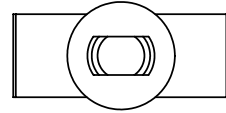

TO SNAP-FIT IN A  $.156 \pm .003$   
[4±0.08] DIA. HOLE, IN A  
.062 [1.57] PANEL THICKNESS

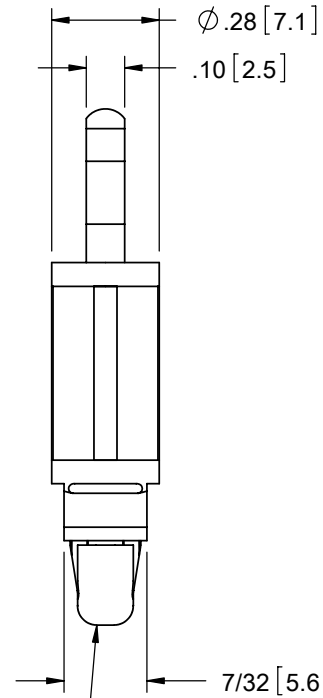
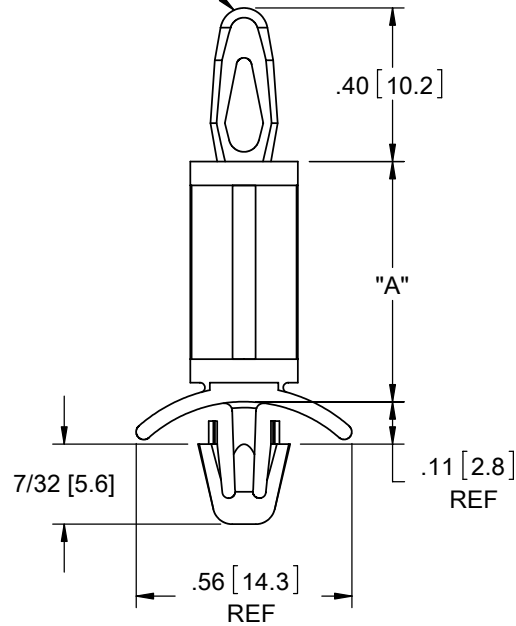

TO SNAP-LOCK IN A  $.187 \pm .003$   
[4.75±0.08] DIA. HOLE, IN A  
.031-.078 [0.79-1.98] PANEL THICKNESS

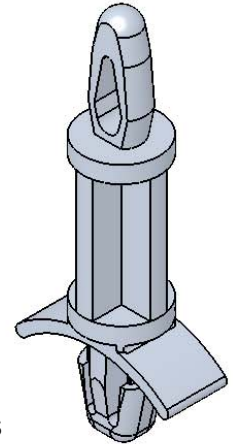

MATERIAL: NYLON 6/6 UL 94 V-2 (RMS-01) PART NO.	DIM. "A"±.015 [0.4]
LCBS-4-3-01	3/16 [4.8]
LCBS-4-4-01	1/4 [6.4]
LCBS-4-5-01	5/16 [7.9]
LCBS-4-6-01	3/8 [9.5]
LCBS-4-7-01	7/16 [11.1]
LCBS-4-8-01	1/2 [12.7]
LCBS-4-10-01	5/8 [15.9]
LCBS-4-12-01	3/4 [19.1]
LCBS-4-14-01	7/8 [22.2]
LCBS-4-16-01	1 [25.4]
LCBS-4-18-01	1-1/8 [28.6]
LCBS-4-20-01	1-1/4 [31.7]
LCBS-4-22-01	1-3/8 [34.9]

NOTES:

1. MATERIAL: NYLON 6/6 UL 94 V-0 (RMS-19), AVAILABLE BY SPECIAL ORDER. TO ORDER REPLACE ".01" WITH "-19".
2. COLOR: NATURAL.
3. ALTERNATE UNITS FOR REFERENCE ONLY.

TITLE: <b>LOCKING CIRCUIT BOARD SUPPORT</b>						DWG IN IN [MM]	
CREATED USING SOLIDWORKS	FILE #: LCBS-4	DWN: SK	APP: RT	FINAL			
TOLERANCES UNLESS NOTED	SHEET: 1 OF 1	SHEET SIZE: A	DT: 08/24/06	CHKD: SJ	PART #		PRINT TYPE
XX=±.010 .XXX=±.005 FRAC.=±1/64 ANG.=±1°	RE: RICHCO, INC.		RICHCO, INC. ENG@RICHCO-INC.COM (773) 539-4060		SEE TABLE		CA

B	REDRAWN, SEE ECN #1208 FOR CHANGES	SK	11/29/06
A	UPDATED PRINT AND CHANGED FILE NO.	SM	09/28/01
REV.	DESCRIPTION	ENGR.	DATE