

PART NO.	BULB TYPE	BASE TYPE	DESIGN VOLTS	DESIGN AMPS	FILAMENT TYPE	AVERAGE LIFE HOURS
222	TL3	MINIATURE SCREW E10	2.25	0.25	C-2R	5

REVISIONS			
REV	DESCRIPTION	DATE	APPROVED
1	ISSUED	04/23/2008	D.C.

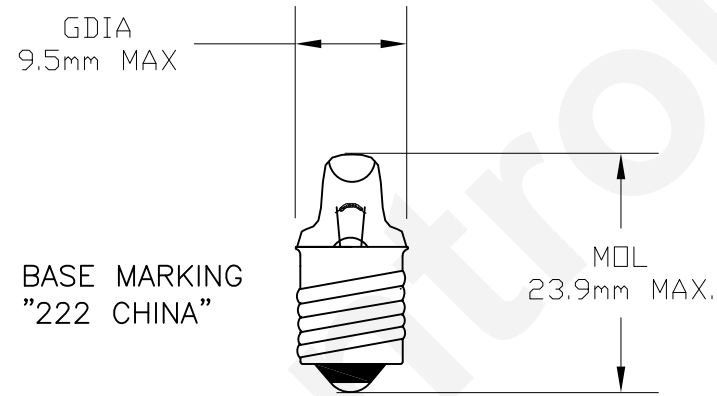

UNLESS OTHERWISE SPECIFIED: DIMENSIONS ARE IN INCHES TOLERANCES		CEC INDUSTRIES LTD			
DECIMALS .XX ± .05 .XXX ± .010 FRACTIONAL ± 1/64		ANGULAR ± 0.5°		599 BOND STREET LINCOLNSHIRE IL 60069	
DRAWN D. C.		DATE 4/23/2008		TITLE LIGHT BULB NO. 222	
CHECKED		SIZE A	FSCM NO.	DWG NO. 222	REV 1
DESIGN		SCALE		PLOT SCALE	SHEET 1 OF 1
MATERIAL		FILE 222.dwg		DO NOT SCALE DRAWING	