

A

B

C

D

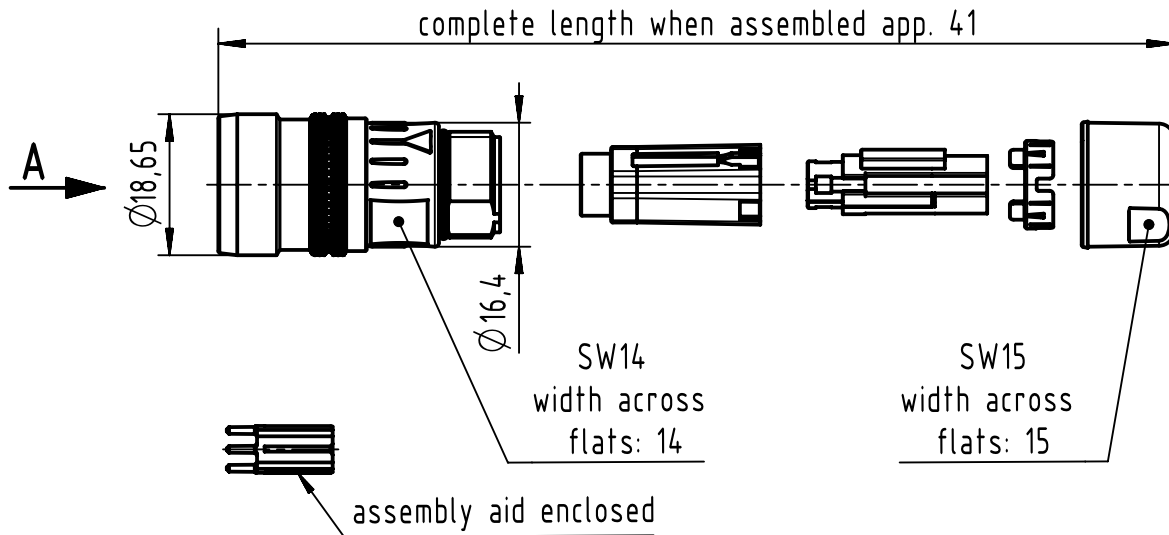

A (2:1)

contact face acc. to IEC 61076-2-101

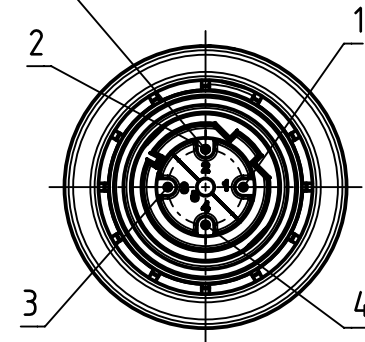

order cable specific set separately  
order contacts separately

wire gauge	part-no contact
AWG 22-18	09 67 000 3576
AWG 24-20	09 67 000 8576
AWG 26-22	09 67 000 5576



	All rights reserved Department EL PD	All Dimensions in mm Original Size DIN A4	Scale 1:1	Free size tol.		Ref.	
		HARTING D-32339 Espelkamp	Created by BALSAN	Inspected by FARCASIU	Standardisation ROEBEN	Date 2022-05-02	State Final Release
Title M12 PP male D-cod 4-pole for crimp flange						Doc-Key / ECM-Nr. 100765181/UGD/001/D 500000216908	
		Type TB	Number 21038811433			Rev. D	Page 1/1