

assembly aid enclosed

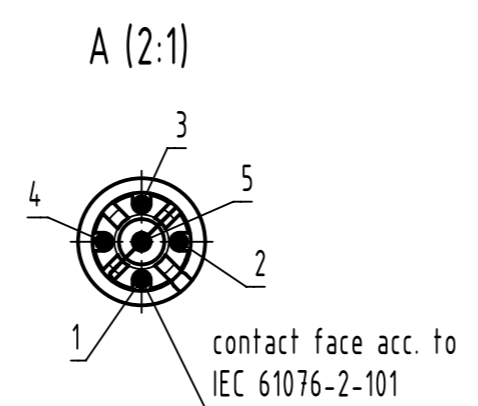

Positions of cable direction

exemplary: Position 0

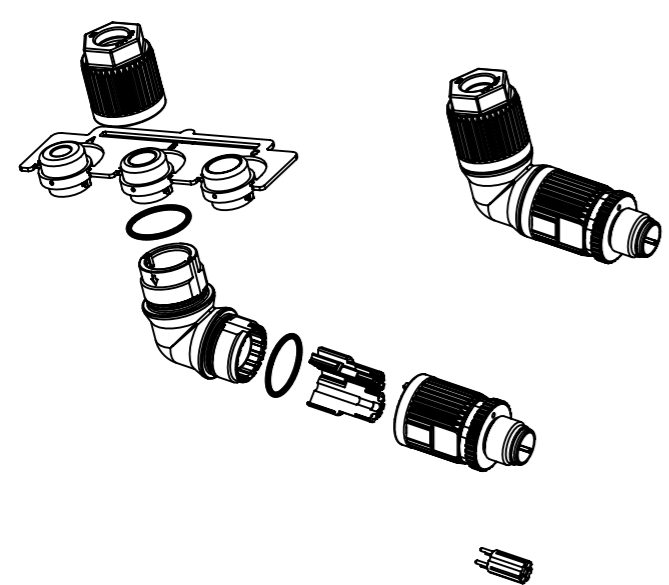
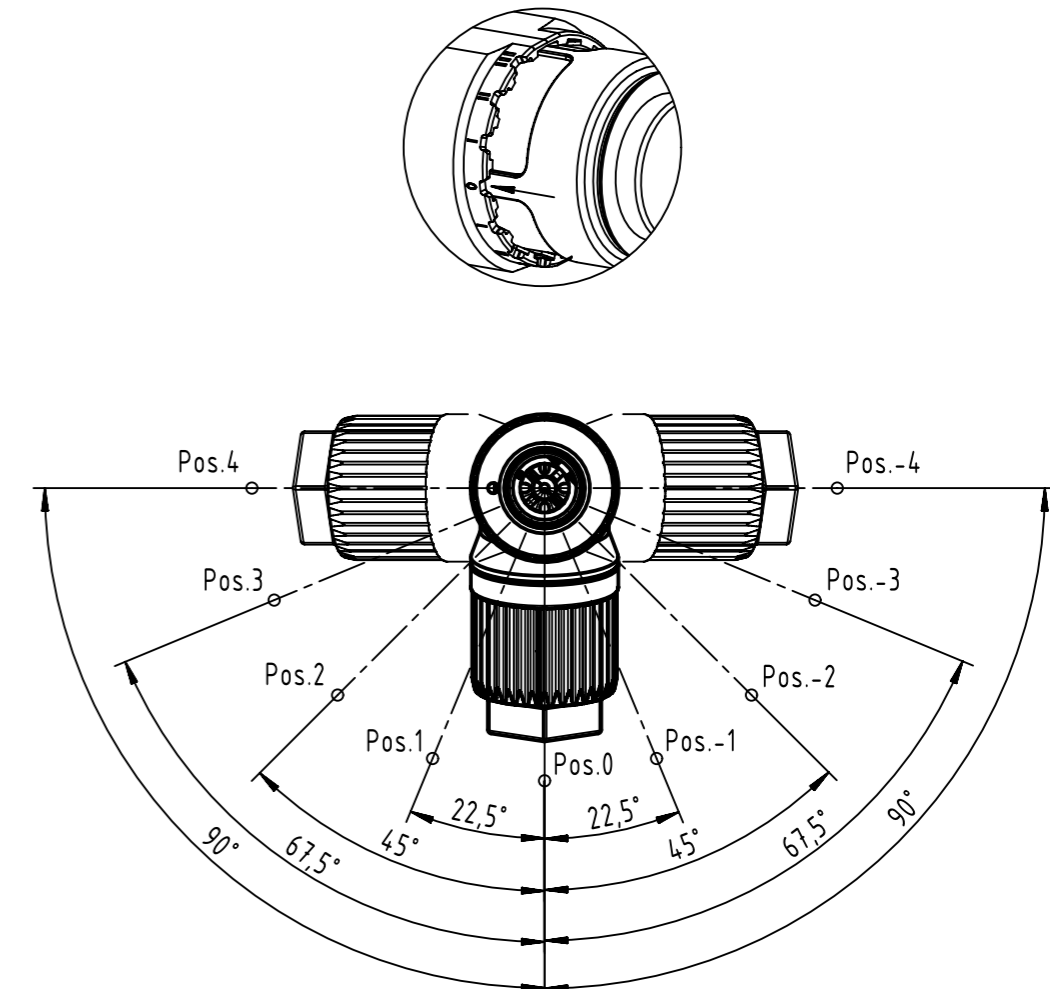

order contacts separately

cable Ø	wire gauge		part-no.
4.5-8.8mm	0.25-0.50mm ²	AWG 24-20	09 67 000 8576
	0.14-0.34mm ²	AWG 26-22	09 67 000 5576
	0.34-0.75mm ²	AWG 22-18	09 67 000 3576

	All rights reserved		Scale 1:1	Free size tol.	Ref.
	Department EL PD		Created by BUSSMANN	Inspected by 104122	Standardisation
HARTING D-32339 Espelkamp		Title HARTING M12 crimp angled male A-coded 5-pole Type TB Number 21038223505			Date 2021-08-31 State Final Release
				Doc-Key / ECM-Nr. 100232639/UGD/004/L 50000201677	Rev. L Page 1/1