

1 2 3 4 5 6

A  
B  
C  
D

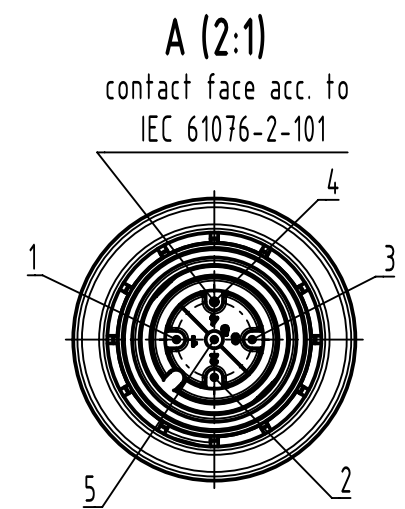
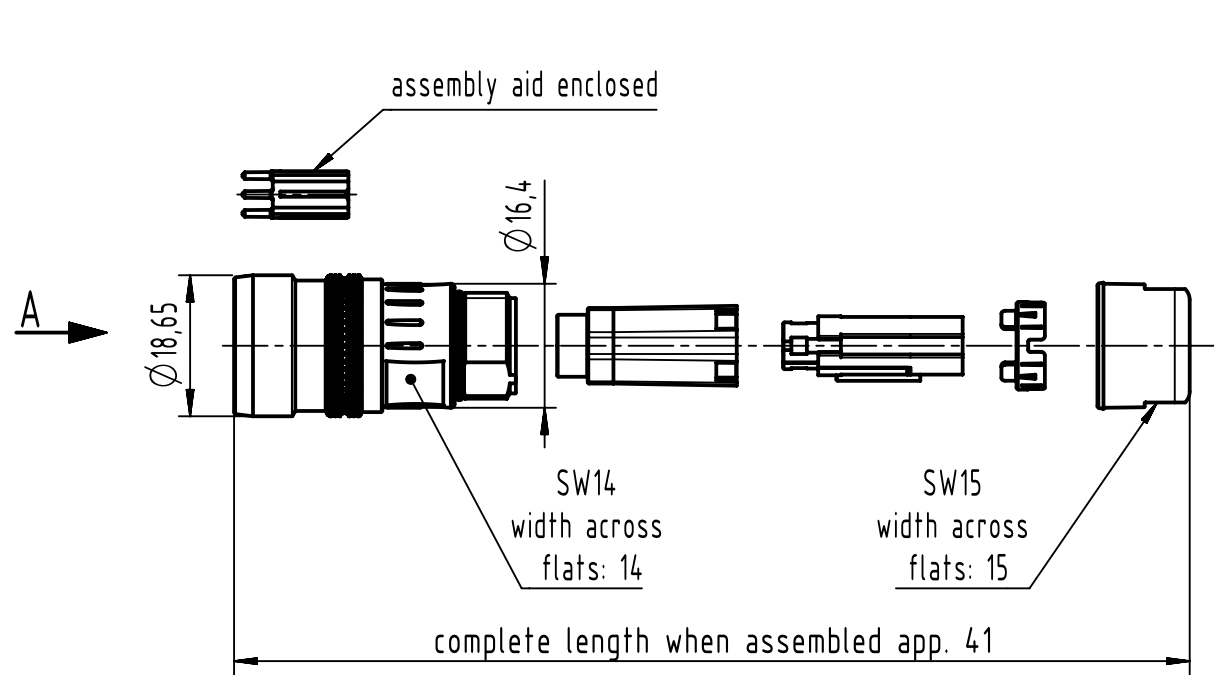

order cable specific set separately  
order contacts separately

wire gauge	part-no contact
AWG 22-18	09 67 000 5576
AWG 24-20	09 67 000 8576
AWG 26-22	09 67 000 3576

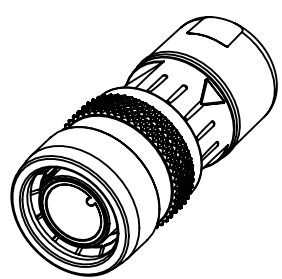

	All rights reserved Department EL PD	Created by BALSAN	Inspected by FARCASIU	Standardisation ROEBEN	Date 2022-05-02	State Final Release	
		Title M12 PP male A-coded 4/5-pole for crimp flange					Doc-Key / ECM-Nr. 100761384 / UGD/000/D 500000216908
HARTING D-32339 Espelkamp		Type TB	Number 21038211533			Rev. D	Page 1/1