

order contacts separately

wire gauge	part-no contact
AWG 22-18	09 67 000 3576
AWG 24-20	09 67 000 8576
AWG 26-22	09 67 000 5576

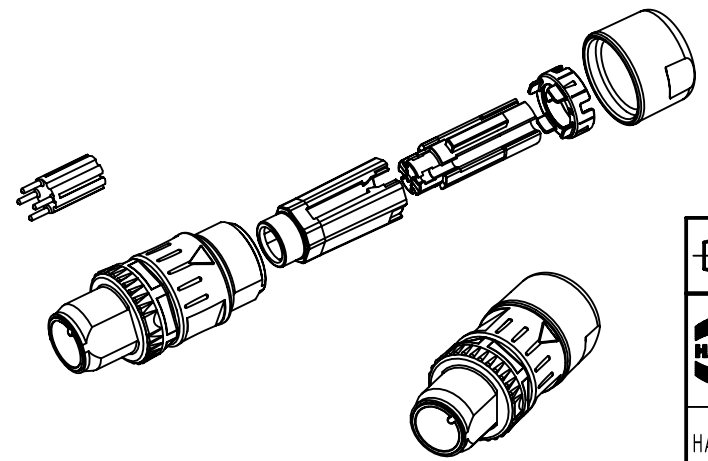

	All rights reserved Department EL PD	All Dimensions in mm Original Size DIN A4		Scale 1:1	Free size tol.	Ref.	
		Created by BALSAN	Inspected by FARCASIU	Standardisation 302077	Date 2020-10-16	State Final Release	Sub.
HARTING Electronics GmbH D-32339 Espelkamp		Title M12 SD A-cod 4/5-pol Crimp Flange male				Doc-Key / ECM-Nr. 100761222/UGD/000/C 500000180065	
		Type TB	Number 21038211507			Rev. C	Page 1/1