

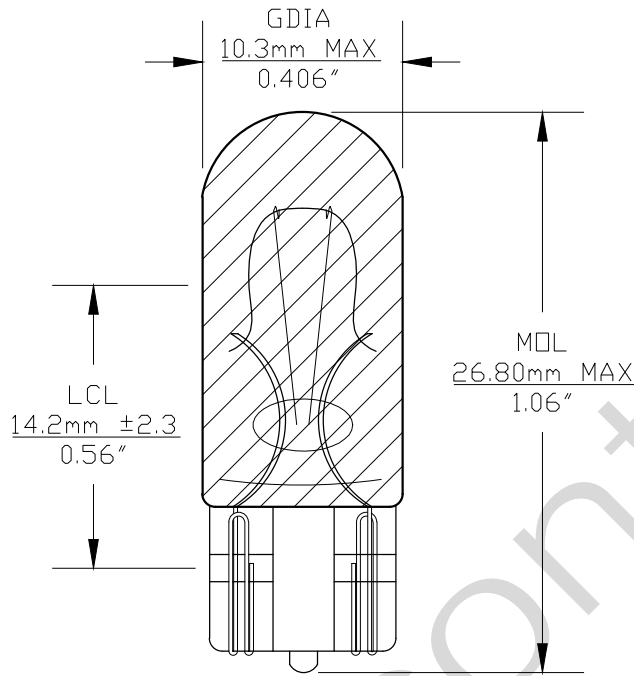

PART NO.	BASE TYPE	DESIGN VOLTS	DESIGN AMPS	MSCD	FILAMENT TYPE	AVERAGE LIFE HOURS
194NA	Glass Wedge T-3 1/4 (W2.1X9.2d)	14.0V	0.27±10%	1.5±30%	C-2F	2500

REVISIONS			
REV #	DESCRIPTION	DATE	APPROVED
1	ISSUED	05/10/2001	E.S.
2	ADDITIONAL DIMENSIONS	05/21/2010	D.C.
3	ADDITIONAL VIEW	05/23/2014	R.M.
4	REVISED LIFE HOURS FROM 1500	08/15/2019	R.M.



0° VIEW

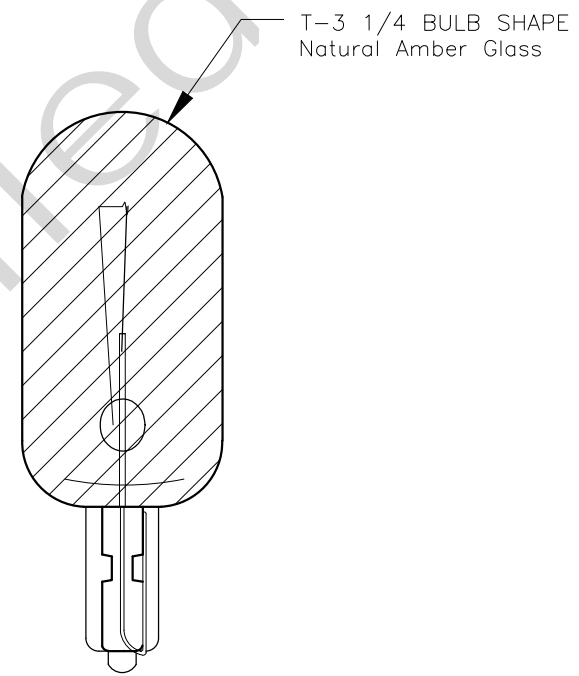

90° VIEW

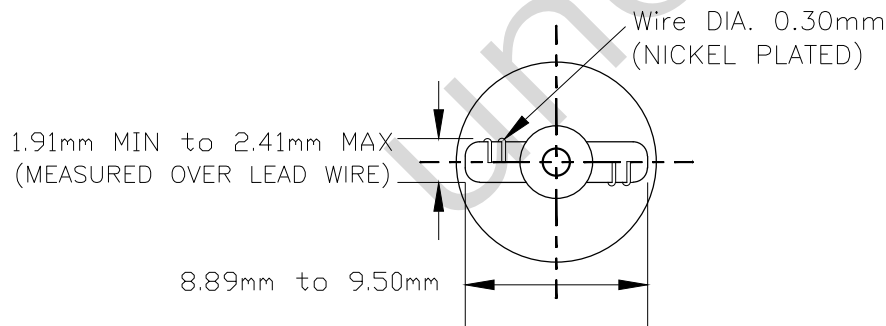

BASE BOTTOM VIEW

Note: Made according to SAE specifications



UNLESS OTHERWISE SPECIFIED: DIMENSIONS ARE IN INCHES TOLERANCES		CEC INDUSTRIES LTD	
DECIMALS	ANGULAR	599 BOND STREET LINCOLNSHIRE, IL 60069	
.XX ± .05	± 0.5°		
.XXX ± .010			
FRACTIONAL	± 1/64		
DRAWN ELIZABETH SONANES	DATE 05/10/2001	TITLE LIGHT BULB NO. 194NA	
CHECKED	SIZE A	FSCM NO.	DWG NO. 194NA
DESIGN	SCALE	PLOT SCALE	REV 4
MATERIAL	FILE 194NA.pdf	SHEET 1 OF 1	
		DRAWING NOT TO SCALE	