

Applicable cable	
Items	Applicable condition
Conductor size	AWG 28-22
Insulation O.D.	Ø1.55mm max.
Braid Shield	Tin plating
Sheath O.D.	Ø5.5mm - Ø7.2mm

Contact material: copper alloy
 Contact area: Gold 0.2µm min.
 Wiring area: Gold 0.03µm min.
 Under plating: Nickel 2µm min.

	All Dimensions in mm Original Size DIN A4	Scale 2:1	Free size tol.	Ref. Sub.	
	All rights reserved Department EL PD	Created by SERBANA	Inspected by PREOTU	Standardisation ROEBEN	Date 2022-05-06
HARTING D-32339 Espelkamp	Title ix Industrial 10B-1 plug SL-S			Doc-Key / ECM-Nr. 100744234/UGD/000/D 500000215569	
Type TB		Number 09451819000		Rev. D	Page 1/2

1 2 3 4 5 6

Shield Shell delivery form

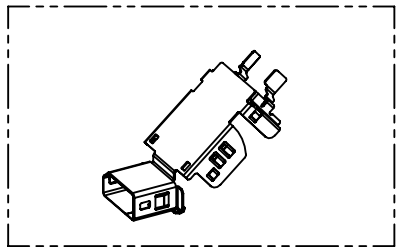

Product Structure

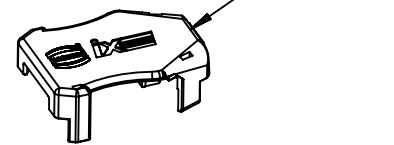

Shield Shell

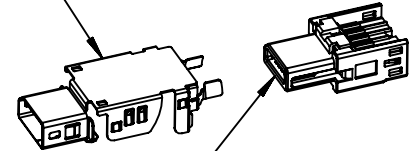

Plug Unit

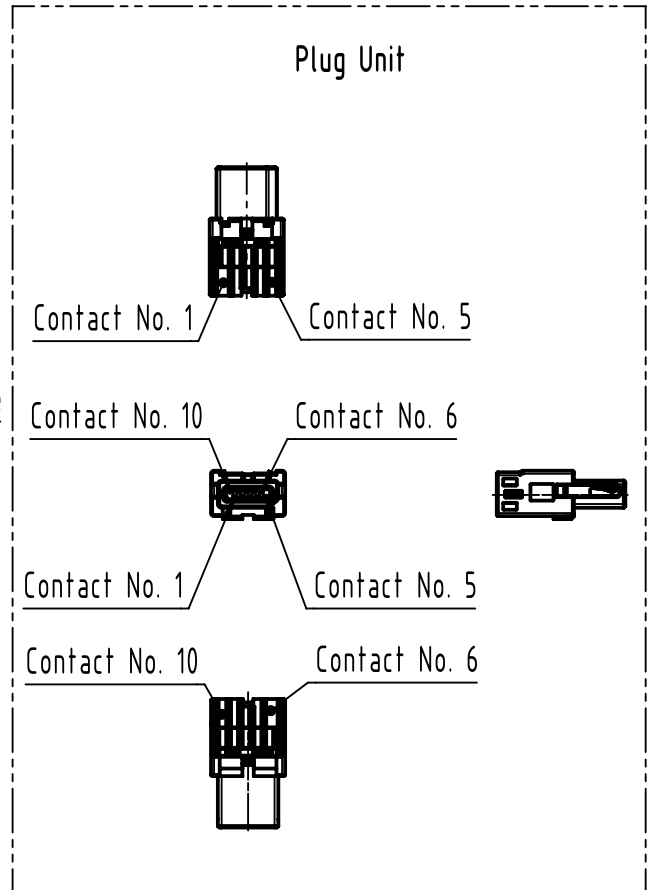
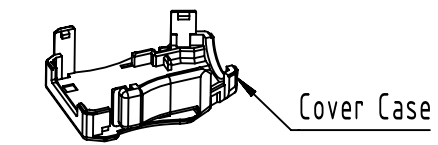

Mating condition (2:1)

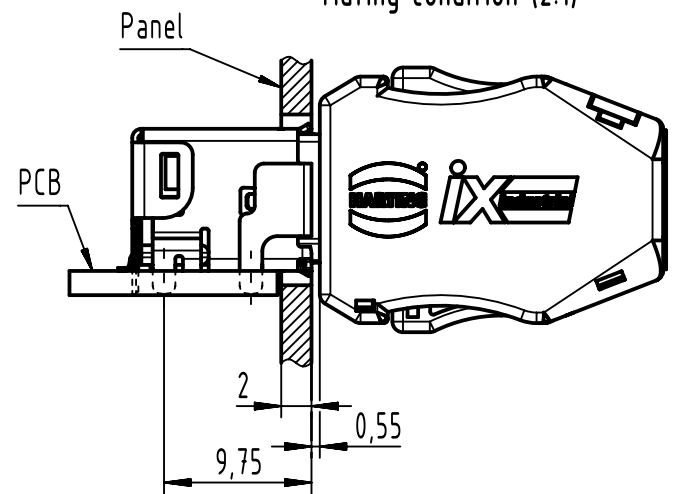

	All rights reserved Department EL PD	Created by SERBANA	Inspected by PREOTU	Standardisation ROEBEN	Date 2022-05-06	State Final Release
	HARTING D-32339 Espelkamp	Title ix Industrial 10B-1 plug SL-S				Doc-Key / ECM-Nr. 100744234/UGD/000/D 500000215569
All Dimensions in mm Original Size DIN A4		Scale 1:1	Free size tol.		Ref.	Sub.