

Applicable cable

| Items | Applicable condition |
|-----------------|----------------------|
| Conductor size | AWG 22 |
| Insulation O.D. | Ø1.4 to 1.6 mm |
| Braid Shield | Tin plating |
| Sheath O.D. | Ø5.5mm - Ø7.2mm |

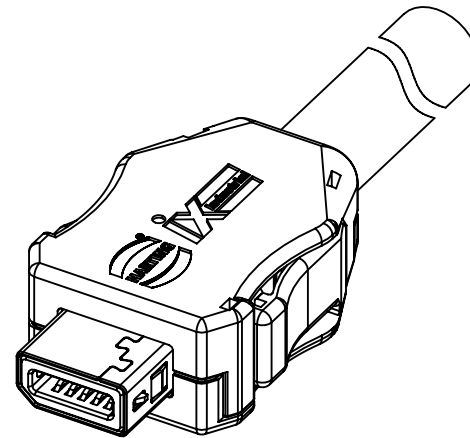

Contact material: copper alloy
 Contact area: Gold 0.2µm min.
 Wiring area: Gold 0.03µm min.
 Under plating: Nickel 2µm min.

| Pin | 10/100 Mbit/s | 1/10 Gbit/s |
|-----|---------------|-------------|
| 1 | TX+ | BI_DA+ |
| 2 | TX- | BI_DA- |
| 3 | N.C. | N.C. |
| 4 | N.C. | BI_DC+ |
| 5 | N.C. | BI_DC- |
| 6 | RX+ | BI_DB+ |
| 7 | RX- | BI_DB- |
| 8 | N.C. | N.C. |
| 9 | N.C. | BI_DD+ |
| 10 | N.C. | BI_DD- |

| | | | | | | | | |
|------------------------------|---|--|--|---------------------------|--------------------|------------------------|---|--|
| | All rights reserved Department EL PD | All Dimensions in mm Original Size DIN A4 | | Scale 2:1 | Free size tol. | | Ref. Sub. | |
| | | Created by SERBANA | Inspected by PREOTU | Standardisation ROEBEN | Date 2022-04-28 | State Final Release | | |
| HARTING D-32339 Espelkamp | | | Title ix Industrial 10A-1 plug SL-I22 | | | | Doc-Key / ECM-Nr. 100979135/UGD/000/B 500000214.732 | |
| Type TB | | Number 09451812563 | | | Rev. B | Page 1/2 | | |

1 2 3 4 5 6

Shield Shell delivery form

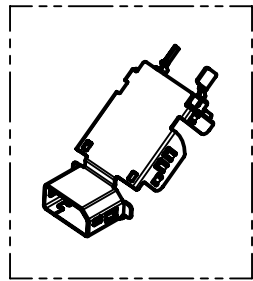

Product Structure

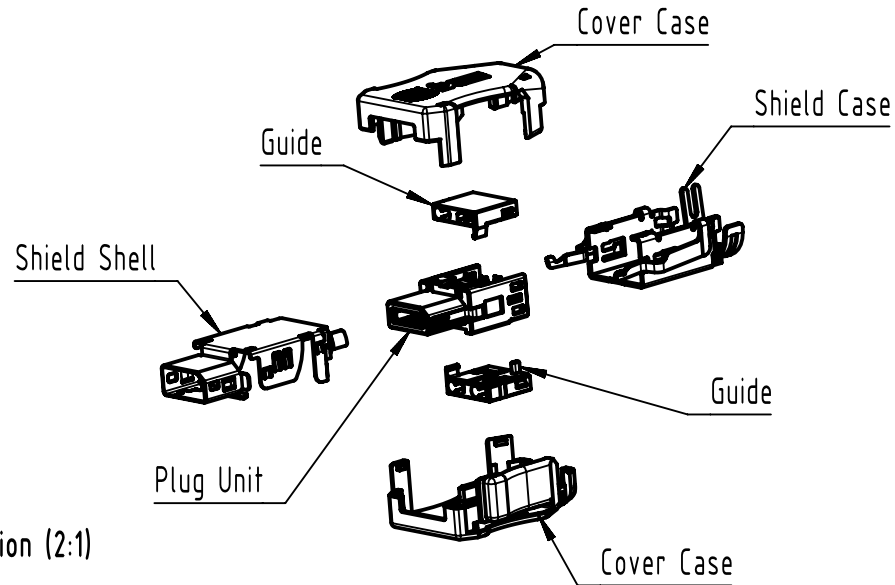

Plug Unit

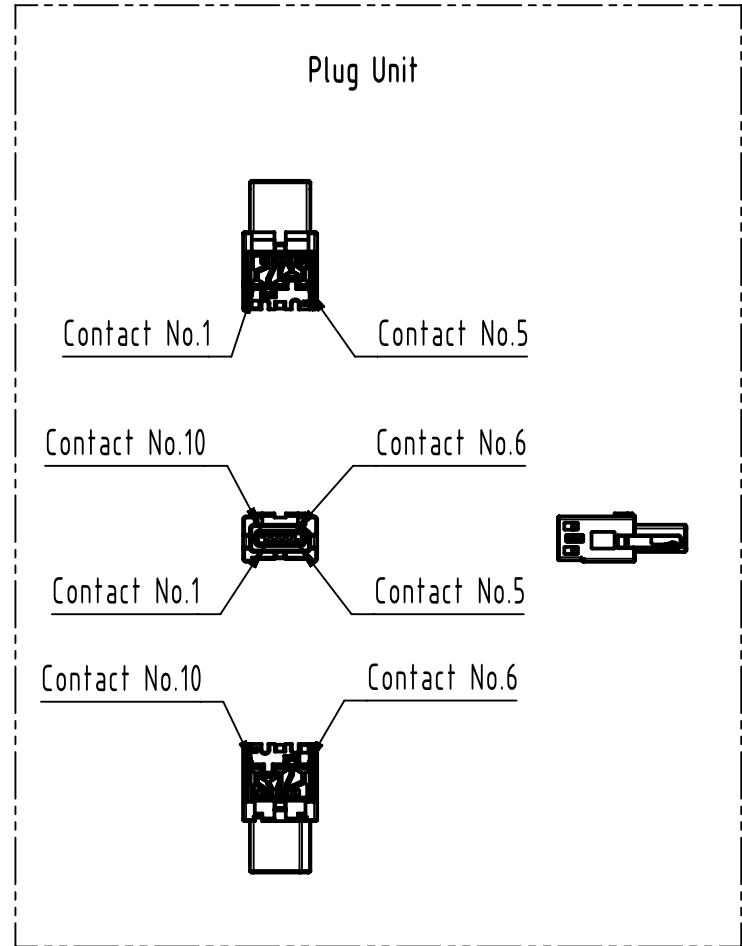

Mating condition (2:1)

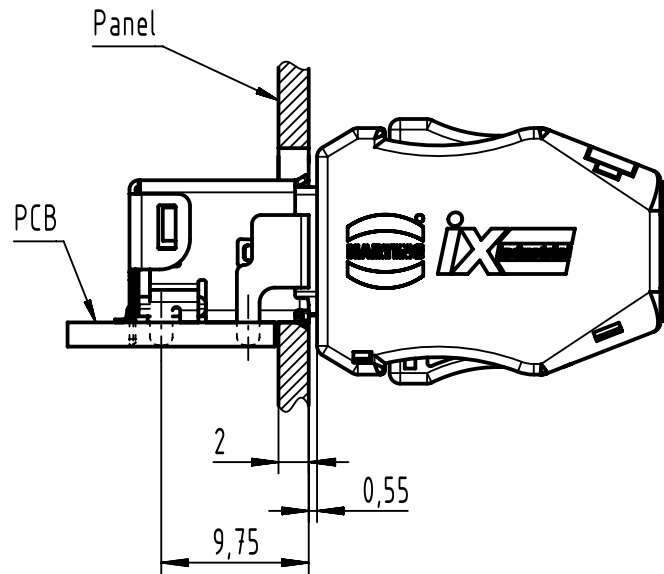

| | | | | | | | |
|--|---|--|------------------------|---------------------------|--------------------|---|-------------|
| | All rights reserved Department EL PD | Created by SERBANA | Inspected by PREOTU | Standardisation ROEBEN | Date 2022-04-28 | State Final Release | |
| | HARTING D-32339 Espelkamp | Title ix Industrial 10A-1 plug SL-I22 | | | | Doc-Key / ECM-Nr. 100979135/UGD/000/B 500000214.732 | |
| | | Type TB | Number 09451812563 | | | Rev. B | Page 2/2 |