

# Technical Data Sheet

# Rosenberger

RPC-N  
50 Ω

Calibration Kit  
Plug

## 05S30R-MSOTS3

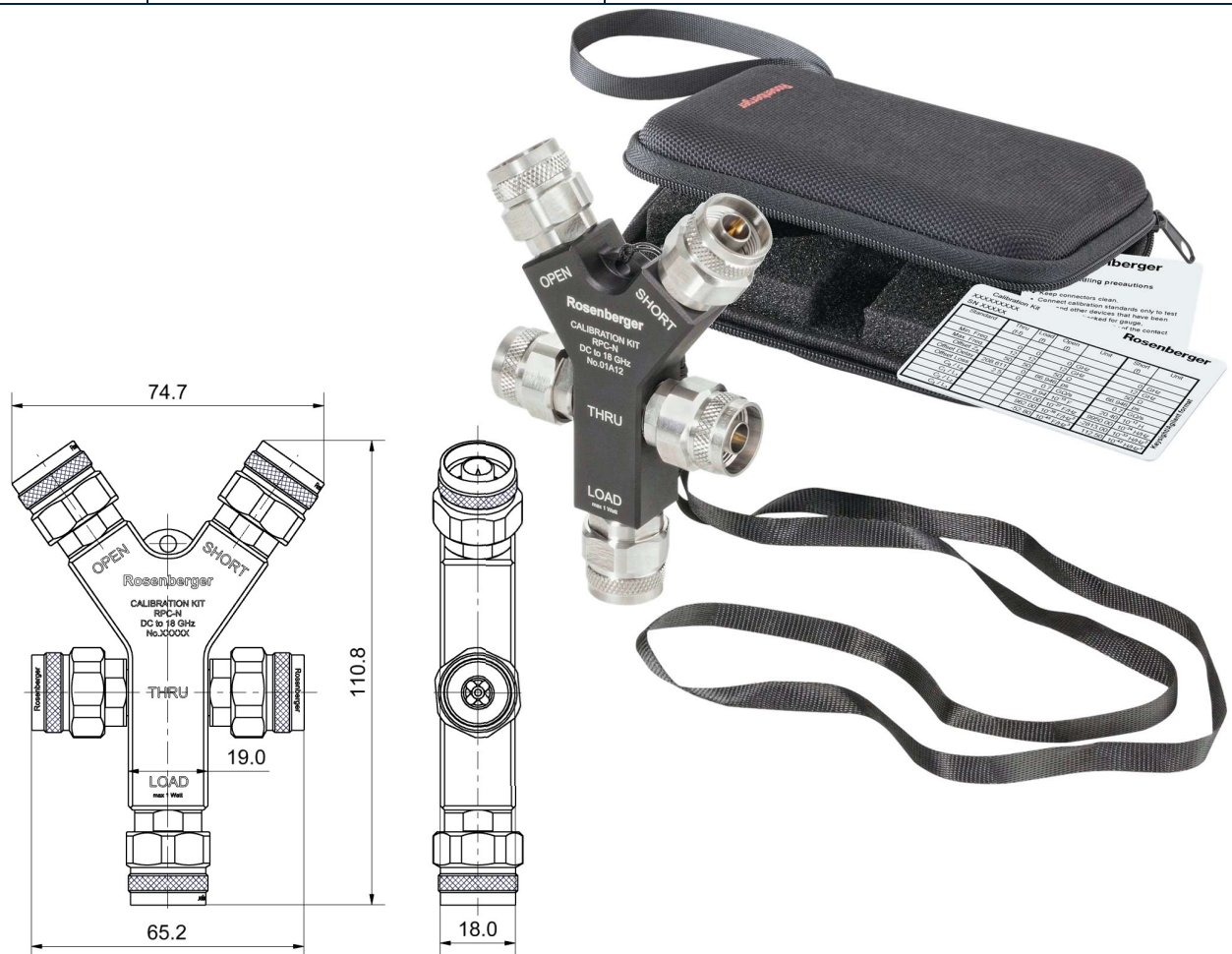

All dimensions are in mm; tolerances according to ISO 2768 m-H

### Interface

According to

IEC 61169-16

### Contents and Documentation

This kit is delivered with

- **Standard Definitions Card**  
Printed Standard Definitions that can be used on nearly all Vector Network Analyzers
- **Certificate of Testing**
- **Lanyard**
- **Hard Shell Case**
- **Protection Caps**
- **User Manual**

### Material and plating

#### Connector parts

Center conductor  
Outer conductor  
Coupling nut  
Body  
Dielectric  
Substrate

#### Material

CuBe  
Stainless steel  
Stainless steel  
Aluminum  
PPE  
Al<sub>2</sub>O<sub>3</sub>

#### Plating

Gold, min. 1.27 μm, over nickel  
Passivated  
Passivated  
black anodized

**Electrical data**

Frequency range	DC to 18 GHz
<b>Thru</b>	
Return loss	≥ 40 dB, DC to 6 GHz ≥ 36 dB, 6 GHz to 9 GHz ≥ 32 dB, 9 GHz to 18 GHz
<b>Open</b>	
Error from nominal phase <sup>1</sup>	≤ 2.0°, DC to 6 GHz ≤ 3.0°, 6 GHz to 9 GHz ≤ 4.0°, 9 GHz to 18 GHz
<b>Short</b>	
Error from nominal phase <sup>2</sup>	≤ 1.5°, DC to 6 GHz ≤ 2.0°, 6 GHz to 9 GHz ≤ 2.5°, 9 GHz to 18 GHz
<b>Load</b>	
Return loss	≥ 42 dB, DC to 6 GHz ≥ 36 dB, 6 GHz to 9 GHz ≥ 30 dB, 9 GHz to 18 GHz
DC-Resistance	50 Ω ± 0.5 Ω
Power handling (at 25 °C, sea level)	≤ 1.0 W, derate by 0.01 W/K

<sup>1</sup> The nominal phase is defined by the Offset Delay, the Offset Loss and the Fringing Capacitances

<sup>2</sup> The nominal phase is defined by the Offset Delay, the Offset Loss and the Short Inductance

**Mechanical data**

Mating cycles	≥ 500
Maximum torque	1.70 Nm
Recommended torque	1.10 Nm
Gauge	5.28 mm to 5.32 mm

**General standard definitions**

For proper operation the vector network analyzer (VNA) needs a model describing the electrical behaviour of this calibration standard. The different models, units, and terms used will depend on the VNA type and they will have to be entered into the VNA. All values are based on typical geometry and plating.

**Thru**

Offset Z <sub>o</sub> / Impedance / Z <sub>o</sub>	50 Ω
Offset Delay	212.814 ps
Length (electrical) / Offset Length	63.80 mm
Offset Loss	2.20 GΩ/s
Loss	0.0407 dB/√GHz
Line Loss @ 1GHz	0.0006 dB/mm

**Open**

Offset Z <sub>o</sub> / Impedance / Z <sub>o</sub>	50 Ω
Offset Delay	73.384 ps
Length (electrical) / Offset Length	22.00 mm
Offset Loss	0.80 GΩ/s
Loss	0.0102 dB/√GHz
Fringing Capacitances	C <sub>0</sub> = -14.2000 x 10 <sup>-15</sup> F / -14.2000 fF C <sub>1</sub> = 400.000 x 10 <sup>-27</sup> F/Hz / 0.40000 fF /GHz C <sub>2</sub> = -16.0000 x 10 <sup>-36</sup> F/Hz <sup>2</sup> / -0.01600 fF /GHz <sup>2</sup> C <sub>3</sub> = 1.00000 x 10 <sup>-45</sup> F/Hz <sup>3</sup> / 0.00100 fF /GHz <sup>3</sup>

# Technical Data Sheet

# Rosenberger

RPC-N  
50 Ω

Calibration Kit  
Plug

## 05S30R-MSOTS3

### Short

Offset $Z_0$ / Impedance / $Z_0$	50 Ω
Offset Delay	73.384 ps
Length (electrical) / Offset Length	22.00 mm
Offset Loss	0.80 GΩ/s
Loss	0.0102 dB/√GHz
Short Inductance	$L_0 = -27.0000 \times 10^{-12} \text{ H} \quad / \quad -27.0000 \text{ pH}$
	$L_1 = 7200.00 \times 10^{-24} \text{ H/Hz} \quad / \quad 7.20000 \text{ pH/GHz}$
	$L_2 = -800.000 \times 10^{-33} \text{ H/Hz}^2 \quad / \quad -0.80000 \text{ pH/GHz}^2$
	$L_3 = 26.0000 \times 10^{-42} \text{ H/Hz}^3 \quad / \quad 0.02600 \text{ pH/GHz}^3$

### Load

Offset $Z_0$ / Impedance / $Z_0$	50 Ω
Offset Delay	0.0000 ps
Length (electrical) / Offset Length	0.000 mm
Offset Loss	0.00 GΩ/s
Loss	0.0000 dB/√GHz

### Environmental data

Operating temperature range <sup>3</sup>	+20 °C to +26 °C
Rated temperature range of use <sup>4</sup>	0 °C to +50 °C
Storage temperature range	-40 °C to +85 °C
RoHS	compliant

<sup>3</sup> Temperature range over which these specifications are valid.

<sup>4</sup> This range is underneath and above the operating temperature range, within the calibration kit is fully functional and could be used without damage

### Declaration of documentation

Standard delivery for this kit includes Test Results. The documentation issued reports which quantities were tested individually, traceable to national / international standards. Model based standard definitions of the calibration standards are reported in Agilent / Keysight, Rohde & Schwarz and Anritsu compatible VNA format.

### Inspection interval

Recommendation	12 months
----------------	-----------

### Packing

Weight	263 g/pce
--------	-----------

While the information has been carefully compiled to the best of our knowledge, nothing is intended as representation or warranty on our part and no statement herein shall be construed as recommendation to infringe existing patents. In the effort to improve our products, we reserve the right to make changes judged to be necessary.

For the installation of the electrotechnical equipment, particular electrotechnical expertise is required.



Draft	Date	Approved	Date	Rev.	Engineering change number	Name	Date
Marcel Panicke	26.11.14	Lars Ramtke	08.06.23	h00	23-0004	Marion Striegler	30.05.23
Rosenberger Hochfrequenztechnik GmbH & Co. KG P.O.Box 1260 D-84526 Tittmoning Germany <a href="http://www.rosenberger.com">www.rosenberger.com</a>				Tel. : +49 8684 18-0 Email : <a href="mailto:info@rosenberger.com">info@rosenberger.com</a>			Page 3 / 3