

S-1110 PoE Media and Rate Converters

 perle.com/products/10-100-1000-poe-media-converters.shtml

PoE / PoE+ Ethernet to Fiber Conversion

- 10/100/1000Base-T to 100/1000Base-X Fiber
- Supplies IEEE 802.3 PoE & PoE+ PSE power
- Compatible with legacy pre-standard PoE devices
- Multiport models: 2, 3 or 4 ports
- Fix fiber ports or empty slot for Cisco and other industry standard SFPs
- Advanced features: PD Reset, Fiber redundancy, Smart Link Pass-Through, Fiber Fault Alert, Auto-MDIX and Loopback



Perle's feature rich **Gigabit rate converting PoE Media Converters** transparently connect copper to fiber while providing Power over Ethernet (PoE) to standards-based PoE and PoE+ compliant devices such as IP cameras, VoIP phones and wireless access points. **S-1110 PoE Media Converters** are also available with support for Extended Temperature ranges.

Perle **PoE Media Converters** are classified as Power Sourcing Equipment (PSE). While using standard UTP cables that carry Ethernet data, Perle PoE media converters can also provide power to one or two Powered Devices (PDs). Perle has PoE media converter models that support the IEEE 802.3af PoE standard (15.4W of power) or the IEEE 802.3at PoE+ standard (30W of power). Learn more about PoE.

Perle **10/100/1000 PoE Ethernet to Fiber Converters** provide an economical path to extend the distance of an existing network with fiber cabling. At the same time they function as PoE injectors to power devices like IP phones, video conferencing equipment, IP cameras and Wi-Fi devices over copper UTP cabling.

Multi-port PoE media converters enable a variety of flexible network designs. They can feature single or dual RJ-45 ports to power one or two PD's per converter and single or dual fiber ports.

Network Administrators can "see-everything" with Perle's advanced features such as Auto-Negotiation, Auto-MDIX, Link Pass-Through, Fiber Fault Alert, and Loopback. This allows for more efficient troubleshooting and less on-site maintenance. These cost and time saving features, along with a lifetime warranty and free worldwide technical support, make Perle's **Gigabit rate converting PoE Media Converters** the smart choice for IT professionals.

Gigabit Rate Converting to Fiber PoE Media Converter Features

Power Over Ethernet (PSE) Performs the Power Sourcing Equipment (PSE) function on 1 or 2 UTP ports for IEEE 802.3af (15.4 watts PoE) and IEEE 802.3at (up to 30 watts PoE+) compliant devices.

Available in PoE and PoE+ models

PoE+ models support both Type 1 (PoE) and Type 2 (PoE+) PD gear

-
- | | |
|---------------------------|---|
| Advanced Power Management | <ul style="list-style-type: none">• Enable/Disable PSE power by UTP port• PD signature detection• Over-Current Protection• PD power classification detection (Class 0,1,2,3,4) |
|---------------------------|---|
-

PD Power Reset Ideal for remotely resetting equipment, this configurable function performs a momentary power reset to the attached Powered Device (PD). When enabled, the media converter will, upon loss of fiber RX, turn off PSE output power supplied to the PD device for 2 seconds then turn the power back on and leave it on until such time that another fiber RX link is lost (after it was re-established). When disabled, a loss of fiber RX has no effect on PSE power to the PD device(s).

-
- | | |
|------------------------|--|
| Powered Device Support | Support is included for a broad range of PD (Powered Devices) <ul style="list-style-type: none">• IEEE Standard PoE/PoE+ (Alternative A and B)• Legacy High Capacitance PDs• Legacy VoIP phones and Wireless Access Points |
|------------------------|--|
-

- | | |
|--------------------------|---|
| Multiport Configurations | <ul style="list-style-type: none">• 2 port – 1 UTP and 1 fiber (fixed fiber or SFP slot)• 3 port - 1 UTP and 2 SFP fiber slots or 2 UTP and 1 fiber (fixed fiber or SFP slot)• 4 port - 2 UTP and 2 SFP fiber slots |
|--------------------------|---|
-

Fiber Redundancy When enabled on dual fiber models, the media converter treats Fiber 1 as the primary and if the link fails, the fiber link is switched over to fiber 2 within 50ms.

Redundant Primary Fiber If the “Fiber Redundancy” feature is also enabled, the primary fiber 1 link is continuously monitored and if is restored for at least 6 seconds, the link will be switched back from the secondary fiber 2 port to the primary fiber 1 port.

Power Strain Relief strap Included with all models, a strain relief strap is provided to ensure a solid and secure power connection to the media converter. Ideal for areas that may be exposed to vibration.

SFP Speed Sensing Automatically detects whether a Gigabit or Fast Ethernet fiber SFP has been inserted and adjusts accordingly.

Auto-Negotiation (802.3u)	<p>The media converter supports auto negotiation. The 1000Base-X fiber interface negotiates according to 802.3 clause 37. The 10/100/1000Base-T negotiates according to 802.3 clause 28 and 40. The 1000Base-X will link up with its partner after the highest common denominator (HCD) is reached and the copper has linked up with its partner. The 1000Base-X will continue to cycle through negotiation transmitting a remote fault of offline (provided this is enabled through the switch setting) until the copper is linked up and the HCDs match.</p>
	<p>The media converter supports auto-negotiation of full duplex, half duplex, remote fault, full duplex pause, asymmetric pause and Auto MDI-X.</p>
Auto-MDIX	<p>Auto-MDIX (automatic medium-dependant interface crossover) detects the signaling on the copper Ethernet interface to determine the type of cable connected (straight-through or crossover) and automatically configures the connection when enabled. The media converter can also correct for wires swapped within a pair.</p>
	<p>The media converter will adjust for up to 120ns of delay skew between the 1000Base-T pairs.</p>
Smart Link Pass-Through	<p>When the Link Mode switch is placed into Smart Link Pass-Through mode, the copper Ethernet port will reflect the state of the 1000Base-X media converter port. This feature can be used whether fiber auto-negotiation is enabled or disabled.</p>
Fiber Fault Alert	<p>With Fiber Fault Alert the state of the 1000Base-X receiver is passed to the 1000Base-X transmitter. This provides fault notification to the partner device attached to the 1000Base-X interface of the media converter. If the 1000Base-X transmitter is off as a result of this fault it will be turned on periodically to allow the condition to clear should the partner device on the 1000Base-X be using a similar technique. This eliminates the possibility of lockouts that occur with some media converters. Applies only when fiber auto-negotiation is disabled.</p>
Pause (IEEE 802.3xy)	<p>Pause signaling is an IEEE feature that temporarily suspends data transmission between two devices in the event that one of the devices becomes overwhelmed. The media converter supports pause negotiation on the 10/100/1000Base-T connection and 1000Base-X fiber connection.</p> <ul style="list-style-type: none"> • With Autoneg on the device will advertise sym and asymmetric pause • With Autoneg off – Pause receive and send will be disabled
Duplex	<p>Full and half duplex operation supported.</p>
Jumbo Packets	<p>Transparent to jumbo packets up to 10KB.</p>
VLAN	<p>Transparent to VLAN tagged packets.</p>

Remote Loopback Capable of performing a loopback on the 1000Base-X fiber interface.

Not what you are looking for? [View all Perle Media Converters.](#)
Need help? [Contact Perle.](#)

Power

Input Supply Voltage PoE models: 46 - 57 vDC
PoE+ models: 52 - 57 vDC

Power Consumption 6 Watts

Power Over Ethernet (PSE) PoE models: maximum to 15.4 watts supplied per port
PoE+ models: up to 30 watts supplied per port

PoE Options Alternative A (power on pins 1,2 and 3,6)
Alternative B (power on pins 4,5 and 7,8)

Legacy PoE (IE VoIP phones and wireless access points) - (reverse polarity on pins 4,5 and 7,8)

Legacy large capacitor detect (pins 4,5 and 7,8)

Power Connector 5.5mm x 9.5mm x 2.1mm barrel socket

Power Adapter

Universal AC/DC adapter 100-240v AC, regulated 48vDC adapter included for PoE
100-240v AC, regulated 56vDC adapter included for PoE+

Indicators

Power (PWR) This green LED is turned on when power is applied to the media converter. Otherwise it is off. The LED will blink slowly when either fiber port is in Loopback test mode. The LED will blink quickly if there is a hardware failure where the reason code can be identified through a combination of FDF,LKF, FDC and PSE indicator LEDs

Fiber link on / Receive activity (LKF 1/2) This green LED is operational only when power is applied. The LED will blink along with transmit/receive data on the fiber port
If a loss of link on the copper port results in a Link Passthrough condition to the fiber port, this LED will blink at a rate of once every 2 seconds until the condition is cleared.

Copper link on / Receive activity (LKC 1/2)	This green LED is operational only when power is applied. The LED will blink along with transmit/receive data on the 10/100/1000 UTP port If a loss of link on the copper port results in a Link Passthrough condition to the fiber port, this LED will blink at a rate of once every 2 seconds until the condition is cleared.
Fiber Duplex (FDF 1/2)	This green LED is operational only when power is applied. The LED is on when the 10/100/1000Base-X link is operational in full duplex mode. The LED is off when in half duplex. If the Auto-Neg switch is turned off, this LED will always be on
Copper Duplex (FDC 1/2)	This green LED is operational only when power is applied. The LED is on when the 10/100/1000Base-T link is operational in full duplex mode. The LED is off when in half duplex
100/1000	This multi-color LED is operational only when power is applied. The LED is green when the speed of the copper ethernet port is running at 1000 Mbps. The LED is yellow when the speed of the copper Ethernet port is running at 100 Mbps. The LED is off when in 10 Mbps.
PSE Status (PSE 1/2)	<p>This LED will signify the status of the PSE function. Using multi-color and blinking the unit will show the following status for the PSE;</p> <p>GREEN — Solid: The PSE has successfully detected a compliant PD and is applying power over the UTP (for legacy pin out simply show active power when applied)</p> <p>YELLOW — Solid: The PSE is not active. This means the PSE has been configured to provide power, but the PD is :</p> <ul style="list-style-type: none"> • Not connected • Has not detected a compliant PD and is not applying power • PSE has turned off power for Reset function <p>OFF — PSE function switch disabled</p> <p>RED — Blinking: Error Conditions</p> <ul style="list-style-type: none"> • Capacitance too High — 1 blink • Resistance too Low or short circuit — 2 blinks • Resistance too high or open circuit — 3 blinks
Switches - accessible through a side opening in the chassis	

Auto-Negotiation (802.3u) *Enabled (Default)* - The media converter uses 802.3u Auto-negotiation on the 10/100/1000Base-T interface. It is set to advertise full duplex, half duplex, pause and remote fault capabilities.
Disabled - The media converter sets the port according to the position of the speed and duplex switches.

Link Mode Link Mode provides a transparency to the state of the copper link allowing for simplified trouble shooting from the devices connected to the media converter.

Normal (Default — Up)
With Fiber Auto Negotiation enabled when the copper link goes down the 1000Base-X link is brought down. The 1000Base-X link will advertise Remote Fault (Link Fault).

With Fiber Auto Negotiation disabled the state of the copper link has no effect on the 1000Base-X link.

Smart Link Pass Through (Down)
With Fiber Auto Negotiation enabled the behavior is as follows. When the copper link goes down the 1000Base-X link is brought down. The 1000Base-X link will advertise Remote Fault (Link Fault). When Remote Fault (Link Fault) is received on the 1000Base-X interface the copper transmitter will be turned off. When the copper receiver is off the 1000Base-X transmitter will be turned off. When the 1000Base-X receiver goes off the copper transmitter will be turned off.

With Fiber Auto-Negotiation disabled the behavior is as follows. When the copper receiver is off the 1000Base-X transmitter will be turned off. When the 1000Base-X receiver goes off the copper transmitter will be turned off.

Effect on 3 and 4 port units: pass-through conditions will be recognized when the state of both copper UTP or fiber port pairs are the same. IE only if both copper ports go down will the fiber port on a 3 port unit be forced inactive.

Fiber Fault Alert The Fiber Fault Alert switch has meaning when Auto-Negotiation is disabled

Enabled (Default - Up)
When the 1000Base-X receiver is off the 1000Base-X transmitter is turned off. Periodically the 1000Base-X receiver will be turned on for a short period to allow the condition to clear if the 1000Base-X link partner is using a similar feature.

Disabled (Down)

Loopback (1/2)	<p>The media converter can perform a loopback on the 1000Base-X fiber interface. <i>Disabled (Default - Up)</i></p> <p><i>Enabled</i> - The 1000Base-X receiver is looped to the 1000Base-X transmitter. The copper transmitter is taken off the interface.</p> <ul style="list-style-type: none"> • A loopback switch for each fiber connection • On dual fiber units, if one or both ports have loopback enable, all copper ports are disabled, but PoE power is maintained. The other fiber port is unaffected.
Speed Copper	<p>100 (Default) 10</p>
Duplex Copper	<p>Full (Default) Half</p>
Fiber Negotiation	<p><i>Up</i>: The Media Converter will negotiate Ethernet parameters on the fiber connection. This will ensure that the most optimal connection parameters will be in effect. If connecting to another Perle Media Converter, this parameter should be set to Auto. The Media Converter Module will advertise 1000Mbps, Full and Half Duplex, no Pause.</p> <p><i>Down</i>: The Media Converter Module's fiber will be fixed to 1000Mbps, Full Duplex.</p>
Auto-MDIX (Internal Strap)	<p>If Auto-Negotiation (802.3u) is enabled, the media converter determines the current cable pinout to use on the copper interface. If Auto-Negotiation (802.3u) is disabled the Media converter will use the RX Energy method on the copper interface to set the port MDI or MDIX whichever is appropriate.</p> <p>Enabled (Default) - Either a straight-through or crossover type cable can be used to connect the media converter to the device on the other end of the cable.</p> <p>Disabled - If the partner device on the other end of the cable does not have the Auto-MDIX feature a specific cable, either a straight-through or crossover will be required to ensure that the media converter's transmitter and the partner devices transmitter are connected to the others receiver. The Media converter's 100Base-TX port is configured as MDI-X with this switch setting.</p>
PSE Power	<p>Settable for each UTP port available.</p> <p>When enabled (UP), the media converter will perform a Power Sourcing Equipment (PSE) function as per IEEE802.3af or 802.3at standards (relevant model).</p> <p>Default is "enabled"</p>

PD Power Reset	<p>This is a technique to perform a power reset on a PD device(s) attached. When enabled (down), the media converter will upon loss of link on any fiber port, turn off PSE output power to the PD device(s) for 2 seconds then turn the power back on. The power remains on until any fiber link transitions from up to down again.</p> <p>With Passthrough enabled (Link Mode enabled and Fiber Auto-Negotiation enabled) , a loss of link on the fiber resulting from a loss of link on the copper, a PD Power Reset will still occur.</p> <p>When PD Power Reset disabled, loss of fiber link has no effect on PSE power to the PD device(s).</p>
Fiber Redundancy (Dual Fiber Models)	<p>When disabled (default), the ports will operate as a 3 or 4 port switch</p> <p>When enabled (Down) the media converter treats Fiber 1 as the primary. If the link fails, the fiber link is switched over to fiber 2 within 50ms.</p> <p>While the primary is active, the link on port 2 will be maintained, but the port will not pass data</p> <p>A redundancy switch-over will not occur if the fiber link was brought down as a result of link pass-through from a copper port.</p>
Redundant Primary (Dual Fiber Models)	<p>If the "Fiber Redundancy" feature is also enabled, the primary fiber 1 link is continuously monitored and if it is restored for at least 6 seconds, the link will be switched back from the secondary fiber 2 port to the primary fiber 1 port</p>
PoE Power Options (Internal Straps)	<p>Set to Alternative A (default): Pins 3,6 Neg, Pins 1,2 Pos</p> <p>Set to Alternative B: Pins 7,8 Neg, Pins 4,5 Pos</p> <p>Set to Legacy Pre-Standard: Pins 7,8 Pos, Pins 4,5 Neg</p>
Connectors	
10/100/1000Base-T	<p>1 or 2 RJ45 connectors.</p> <p>2 pair CAT5, EIA/TIA 568A/B or better cable for 10/100.</p> <p>4 pair CAT5 UTP cable for Gigabit.</p>
Magnetic Isolation	<p>1.5kv</p>
Fixed Fiber	<p>Available on single fiber port models with 1 or 2 copper UTP ports</p> <p>Dual multimode or single mode (Duplex) fiber - SC, ST</p> <p>Single strand fiber (Simplex) - SC</p> <p>LC - obtained by inserting an SFP (LC) in an SFP slot model</p>

Small Form Factor Pluggable (SFP) slot	SFP slot models: Empty slot for 1000Base-X or 100Base-X SFP modules supplied by Perle, Cisco or other manufacturers of MSA compliant SFPs. Hot insertion and removable (hot swappable).
---	---

Filtering

Filtering	1024 MAC Addresses
------------------	--------------------

Frame Specifications

Buffer	1000 Kbits frame buffer memory
---------------	--------------------------------

Size	Maximum frame size of 10,240 bytes -- Gigabit Maximum frame size of 2048 bytes -- Fast Ethernet
-------------	--

Environmental Specifications

Operating Temperature	0 C to 50 C (32 F to 122 F)
------------------------------	-----------------------------

Storage Temperature	minimum range of -25 C to 70 C (-13 F to 158 F)
----------------------------	---

Operating Humidity	5% to 90% non-condensing
---------------------------	--------------------------

Storage Humidity	5% to 95% non-condensing
-------------------------	--------------------------

Operating Altitude	Up to 3,048 meters (10,000 feet)
---------------------------	----------------------------------

Heat Output (BTU/HR)	20.5
-----------------------------	------

MTBF (Hours)

Calculation model based on MIL-HDBK-217-FN2 @ 30 °C

Model Type	No Power Adaptor	PoE	PoE+
1 UTP, fixed fiber	361,190	206,434	78,317
1 UTP, 1 SFP	410,188	221,560	80,399
1 UTP, 2 SFP	399,432	218,384	79,977
2 UTP, fixed fiber	292,529	182,017	74,524
2 UTP, 1 SFP	323,861	193,675	76,407
2 UTP, 2 SFP	317,119	191,244	76,026

Chassis	Metal with an IP20 ingress protection rating
----------------	--

Mounting

Din Rail Kit	Optional
Rack Mount Kit	Optional
Product Weight and Dimensions	
Weight	0.45 Kg, 1.0 lbs (no power adaptor)
Dimensions	150 x 95 x 26 mm, 5.9 x 3.7 x 1.0 inches
Packaging	
Shipping Weight	PoE models: 1.1 Kg, 2.4 lbs PoE+ models: 1.4 Kg, 3.1 lbs
Shipping Dimensions	300 x 200 x 70 mm, 11.8 x 7.9 x 2.8 inches
Regulatory Approvals	
	FCC Part 15 Class A, EN55022 Class A
	CISPR 22 Class A CISPR 32:2015/EN 55032:2015 (Class A) CISPR 24:2010/EN 55024:2010
Emissions	EN61000-3-2
Immunity	EN55024
	UL/EN/IEC 62368-1 CAN/CSA C22.2 No. 62368-1
	UL 60950-1 IEC 60950-1(ed 2); am1, am2 EN 60950-1:2006+A11:2009+A1:2010+A12:2011+A2:2013
Electrical Safety	CE
Environmental	Reach, RoHS and WEEE Compliant
	ECCN: 5A991
	HTSUS Number: 8517.62.0020
Other	Perle Limited Lifetime Warranty

Gigabit Fiber to IP Cameras

Connect 10/100/1000 IP Cameras to Gigabit Backbone

Extend the reach to IP cameras using fiber media converters. Security cameras are typically installed in remote locations throughout a facility. For cameras that are in the ceiling or other inaccessible areas like rooftops, light poles, along fences, pipelines and transit routes, the cost of bringing electrical power to each camera is eliminated by powering the equipment through the UTP cable using a PoE media converter. For cameras with Pan-Tilt-Zoom (PTZ) that may require higher power, PoE+ models that can supply up to 30 watts of power are also available. PoE+ may also be required for cameras used in cold environments that feature de-icers and blowers.

Fiber is run from an existing data closet to an area with access to power. A PoE Media Converter can be powered by either 48vDC or standard 100 to 240 AC power. The media converter is attached to the power supply and the fiber cable. Copper (UTP or STP cable) Ethernet can be extended another 100 meters to the IP camera. The PoE Media Converter is converting the data from fiber to copper, adding power and transmitting it to the security camera.

To simplify cabling, multiport PoE media converters enable chaining, with a fiber uplink port and a fiber downlink port, of the fiber between media converters (also known as a bus architecture).

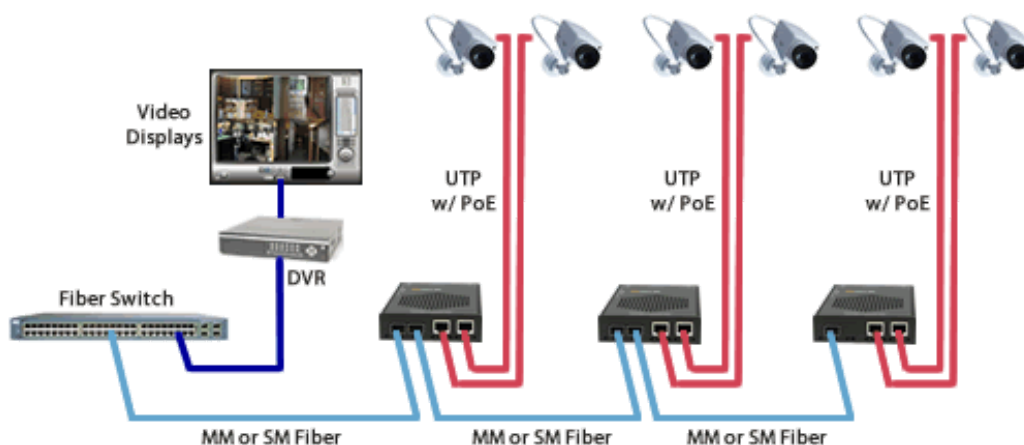

A second option is to have redundant fiber links for installations requiring fiber facility protection. There is an active fiber port and a protection fiber port that can support a fiber failure switchover of less than 50 milliseconds. The PoE+ media converter supplies power to the camera, and has power protection from an Uninterruptible Power Supply (UPS) battery back-up. In the event of a fiber cut and a loss of power, the camera continues to send data on the protection link.

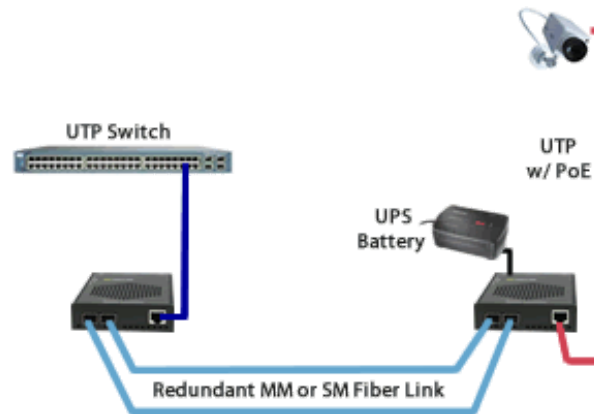

Gigabit Fiber to Wireless Access Points

Connect 10/100/1000 Wireless Access Points to Gigabit Backbone

Extend the reach to wireless access points (AP) using fiber media converters. When a company deploys a wireless network in their office or large warehouse, APs need to be set up throughout the facility to ensure complete coverage for reliability. The network manager will likely need to extend further than the 100 meters allowed by copper cable to reach many of the APs.

For APs that are in the ceiling or other inaccessible areas, PoE media converters can also provide standard PoE power including pre-standard power for those access points that were deployed prior to ratification IEEE 802.3af. For wireless access points as those containing dual radios requiring more than 15.4 watts of power, PoE+ models delivering up to 30 watts are also available.

Fiber is run from an existing data closet to an area with access to power. A PoE Media Converter can be powered by either 48vDC or standard 100 to 240 AC power. The media converter is attached to the power supply and the fiber cable. Copper (UTP or STP cable) Ethernet can be extended another 100 meters to the Wireless Access Point. The PoE Media Converter is converting the data from fiber to copper, adding power and transmitting it to the AP.

To simplify cabling, multiport PoE media converters enable chaining, with a fiber uplink port and a fiber downlink port, of the fiber between media converters (also known as a bus architecture).

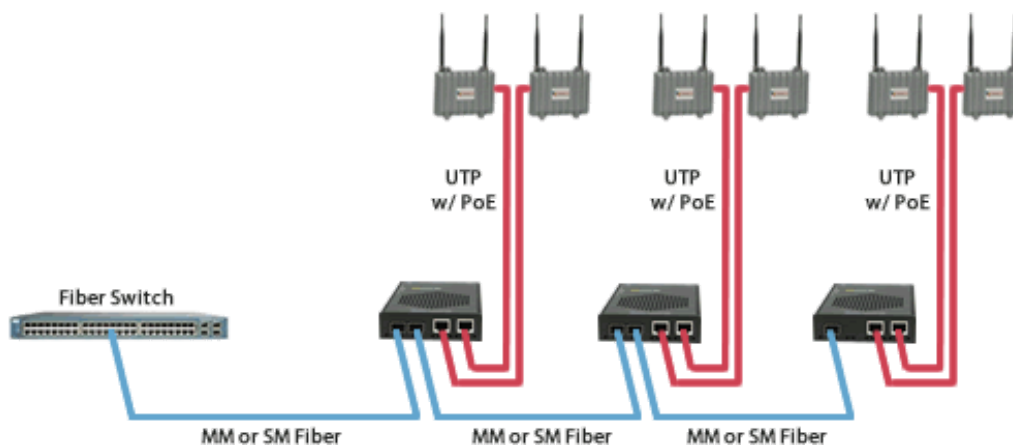

A second option is to have redundant fiber links for installations requiring fiber facility protection. There is an active fiber port and a protection fiber port that can support a fiber failure switchover of less than 50 milliseconds. The PoE+ media converter supplies power to the camera, and has power protection from an Uninterruptible Power Supply (UPS) battery back-up. In the event of a fiber cut and a loss of power, the camera continues to send data on the protection link.

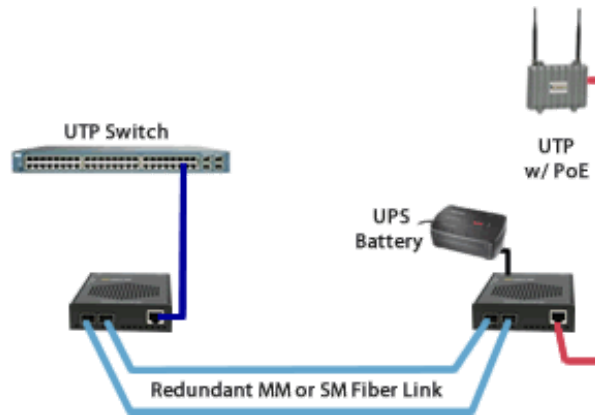

Gigabit Fiber to the Desktop / VoIP (Voice over IP) Phones

Connect 10/100/1000 workstations and VoIP Phones to a Gigabit Backbone

Extend the reach to your workstation and VoIP phones using fiber media converters. PoE media converters can also provide standard PoE power including pre-standard power for those VoIP phones that were deployed prior to ratification of the IEEE 802.3af standard.

For VoIP phones such as those containing dual radios requiring more than 15.4 watts of power, PoE+ models delivering up to 30 watts are also available.

Fiber is run from an existing data closet to an area with access to power. A PoE Media Converter can be powered by either 48VDC or standard 100 to 240 AC power. The media converter is attached to the power supply and the fiber cable. Copper (UTP or STP cable) Ethernet can be extended another 100 meters to the VoIP phone. The PoE Media Converter is converting the data from fiber to copper, adding power and transmitting it to the VoIP phone.

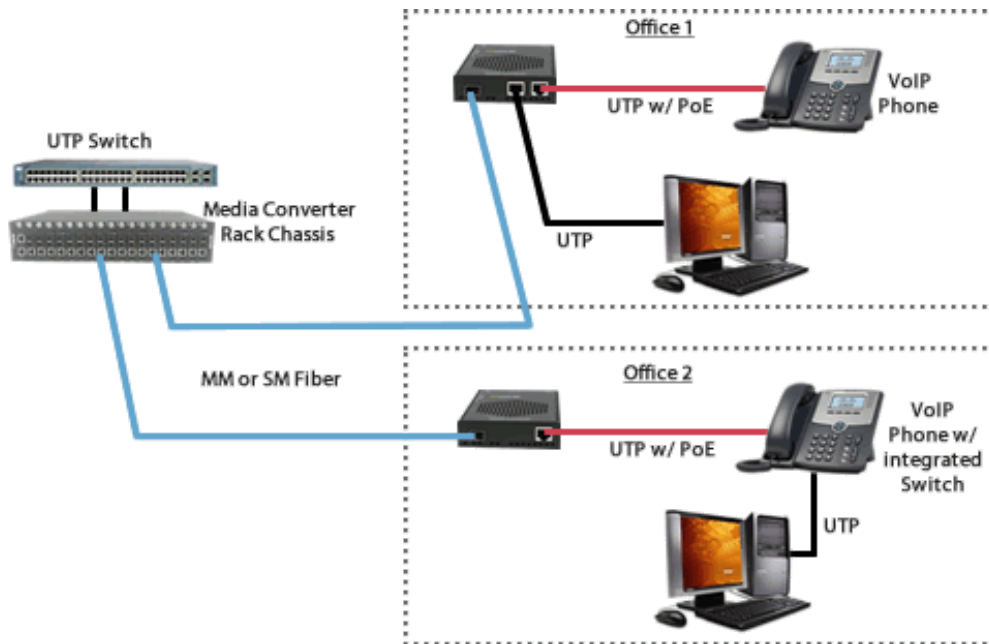
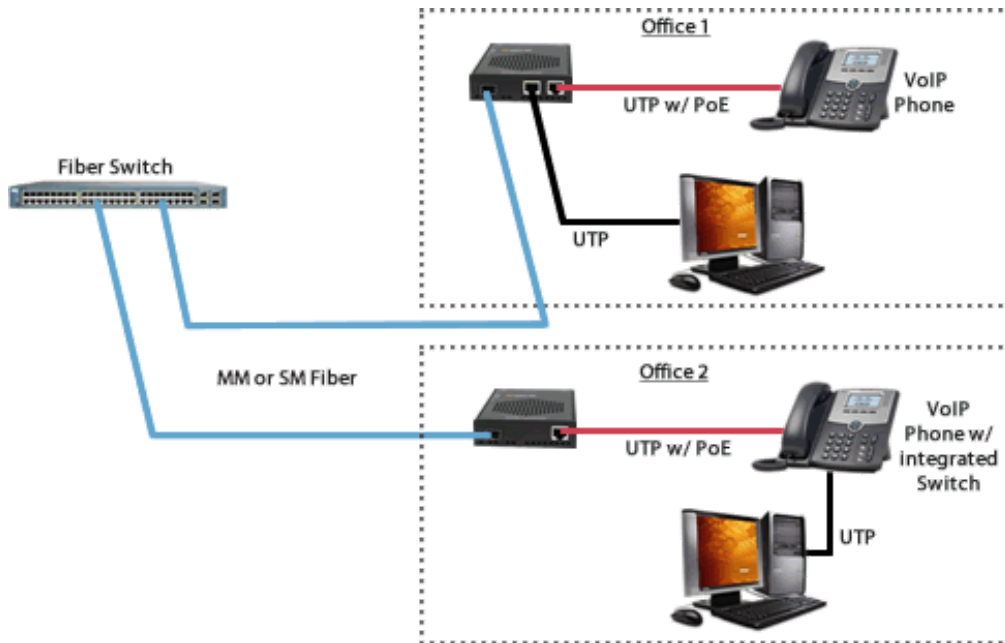

Redundant Dual-Fiber Uplink

Assured Fiber Uplink Connectivity for your critical equipment

When extending the reach of your critical Ethernet equipment using fiber media converters, a dual fiber port media converter with Fiber Redundancy capability provides a fast switch-over of link traffic from one fiber connection to the other converters.

Two modes of operation are possible.;

1. **Redundant Fiber** : When the primary link fails, the media converter redirects traffic to the other fiber port within 50ms.

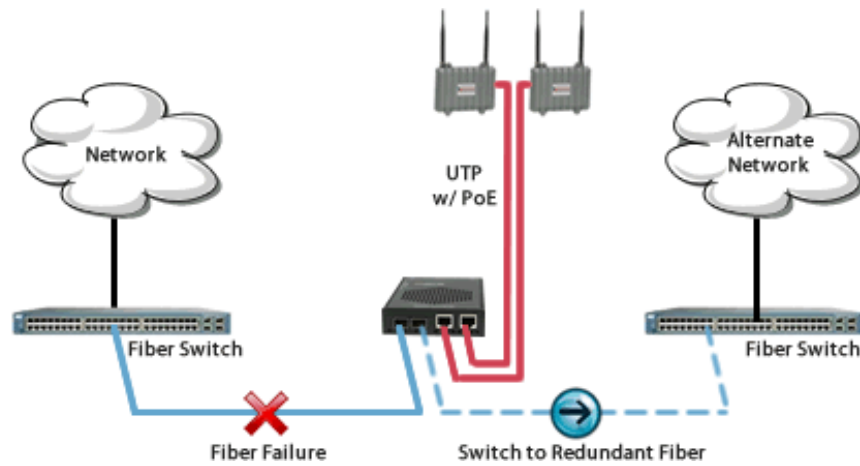

2. **Redundant Primary** : When the primary link fails, the media converter redirects traffic to the secondary fiber port within 50ms. Upon restoration of the primary fiber link, traffic is automatically redirected back to the primary fiber.

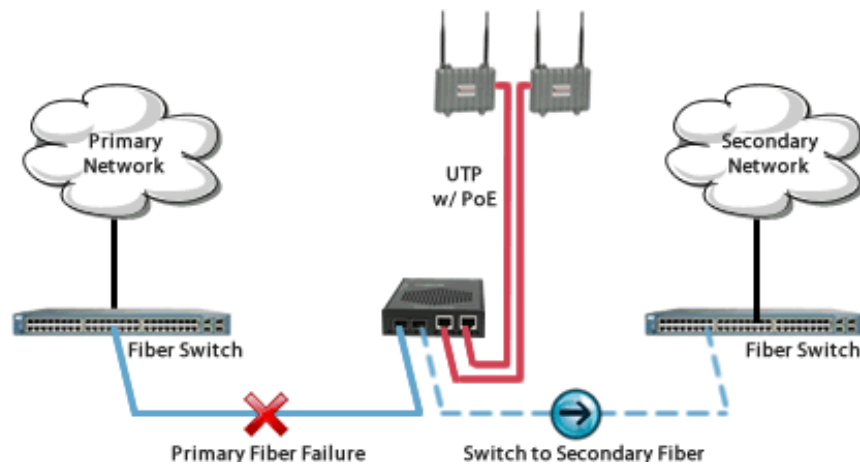

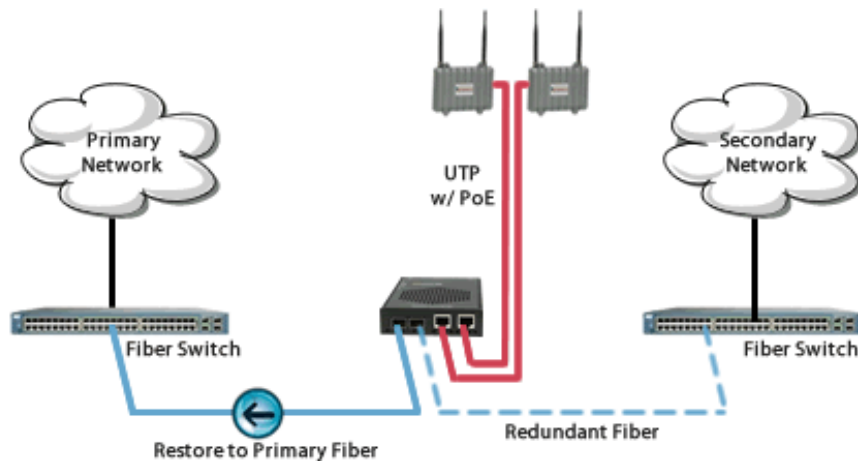

Single Mode / Single Fiber

Connect copper ports over a single fiber strand (also referred to as “Bi-Directional” BiDi)

When Single Strand fiber is used, a pair of Single Fiber Media Converters is needed for the copper to fiber conversion. Perle Single Fiber Media Converters are also referred to as “Up/Down” models. For example the S-1110P-S1SC10U (“Up”) and S-1110P-S1SC10D (“Down”), shown below, must be used in pairs. An “Up” must be matched with a “Down” peer to deal with transmit and receive frequencies separately.

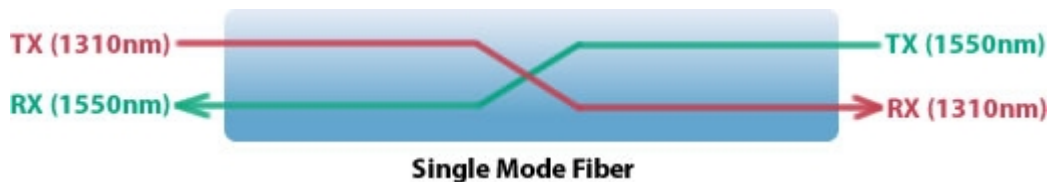

S-1110-S1SC10US-1110-S1SC10D

The majority of installations for single mode fiber media converters are of the “dual connector” or “dual fiber” type where one fiber connection is used for transmit, the other for receive. These are physically “crossed” to match up the Transmit/Receive links.

However, to reduce costs, or where there are limits on available fiber, WDM technology may be utilized. WDM uses separate transmit and receive frequencies to communicate on a single fiber strand. WDM technology relies on the fact that optical fibers can carry many wavelengths of light simultaneously without interaction between each wavelength. Thus, a single fiber can carry many separate wavelength signals or channels simultaneously.

So remember, if Single Strand fiber is used, you will need an “Up” Media Converter on one side and a “Down” Media Converter on the other for copper to fiber conversion.

Select a Model to obtain a Part Number - 10/100/1000 PoE

Model	# PoE ports	Fiber Port Connector	Type	Transmit (dBm)		Receive (dBm)		Power Budget (dBm)	Wavelength (nm)	Fiber Type	Core Size (um)	Modal Bandwidth (MHz*km)	Operating Distance
				Min	Max	Min	Max						
S-1110P-SFP	1	1 x SFP / LC	1000Base-X /100Base-X	-	-	-	-	-	-	MMF /SMF	-	-	-
S-1110P-DSFP	1	2 x SFP / LC	1000Base-X /100Base-X	-	-	-	-	-	-	MMF /SMF	-	-	-
S-1110P-M2SC05	1	Dual SC	1000Base-SX	-9.5	-4.0	-17	-3.0	7.5	850	MMF	62.5	160	220 m (722 ft)
											62.5	200	275 m (902 ft)
											50	400	500 m (1,640 ft)
											50	500	550 m (1,804 ft)
											50	2000	1000 m (3281 ft)
S-1110P-M2ST05	1	Dual ST	1000Base-SX	-9.5	-4.0	-17	-3.0	7.5	850	MMF	62.5	160	220 m (722 ft)
											62.5	200	275 m (902 ft)
											50	400	500 m (1,640 ft)
											50	500	550 m (1,804 ft)
											50	2000	1000 m (3281 ft)
S-1110P-M2SC2	1	Dual SC	1000Base-LX	-6.0	0.0	0.0	-17.0	6.0	1310	MMF	62.5	160	2 km (1.2 mi)
											50	500	1000m (3280 ft)
S-1110P-M2ST2	1	Dual ST	1000Base-LX	-6.0	0.0	0.0	-17.0	6.0	1310	MMF	62.5	160	2 km (1.2 mi)
											50	500	1000m (3280 ft)
S-1110P-S2SC10	1	Dual SC	1000Base-LX/LH	-9.5	-3.0	-20	-3.0	10.5	1310	MMF*	62.5	500	550 m (1,804 ft)
											50	400	550 m (1,804 ft)
											50	400	550 m (1,804 ft)
										SMF	**	-	10 km (6.2 mi)
S-1110P-S2ST10	1	Dual ST	1000Base-LX/LH	-9.5	-3.0	-20	-3.0	10.5	1310	MMF*	62.5	500	550 m (1,804 ft)
											50	400	550 m (1,804 ft)
											50	400	550 m (1,804 ft)
										SMF	**	-	10 km (6.2 mi)

S-1110P-S2SC40	1	Dual SC	1000Base-EX	-2.0	2.0	-23	-3.0	21	1310	SMF	**	-	40 km (25 mi)
S-1110P-S2ST40	1	Dual ST	1000Base-EX	-2.0	2.0	-23	-3.0	21	1310	SMF	**	-	40 km (25 mi)
S-1110P-S2SC70	1	Dual SC	1000Base-ZX	-2.0	5.0	-23	-3.0	21	1550	SMF	-	-	70 km (43 mi)
S-1110P-S2ST70	1	Dual ST	1000Base-ZX	-2.0	5.0	-23	-3.0	21	1550	SMF	-	-	70 km (43 mi)
S-1110P-S2SC120	1	Dual SC	1000Base-ZX	0.0	5.0	-32.0	-9.0	32	1550	SMF	-	-	120 km (75 mi)
S-1110P-S2ST120	1	Dual ST	1000Base-ZX	0.0	5.0	-32.0	-9.0	32	1550	SMF	-	-	120 km (75 mi)
S-1110P-S2SC160	1	Dual SC	1000Base-ZX	2.0	5.0	-32.0	-9.0	34	1550	SMF	-	-	160 km (100 mi)
S-1110P-S2ST160	1	Dual ST	1000Base-ZX	2.0	5.0	-32.0	-9.0	34	1550	SMF	-	-	160 km (100 mi)
S-1110DP-SFP	2	1 x SFP / LC	1000Base-X /100Base-X	-	-	-	-	-	-	MMF /SMF	-	-	-
S-1110DP-DSFP	2	2 x SFP / LC	1000Base-X /100Base-X	-	-	-	-	-	-	MMF /SMF	-	-	-
S-1110DP-M2SC05	2	Dual SC	1000Base-SX	-9.5	-4.0	-17	-3.0	7.5	850	MMF	62.5	160	220 m (722 ft)
											62.5	200	275 m (902 ft)
											50	400	500 m (1,640 ft)
											50	500	550 m (1,804 ft)
											50	2000	1000 m (3281 ft)
S-1110DP-M2ST05	2	Dual ST	1000Base-SX	-9.5	-4.0	-17	-3.0	7.5	850	MMF	62.5	160	220 m (722 ft)
											62.5	200	275 m (902 ft)
											50	400	500 m (1,640 ft)
											50	500	550 m (1,804 ft)
											50	2000	1000 m (3281 ft)
S-1110DP-M2SC2	1	Dual SC	1000Base-LX	-6.0	0.0	0.0	-17.0	6.0	1310	MMF	62.5	160	2 km (1.2 mi)
											50	500	1000m (3280 ft)
S-1110DP-M2ST2	1	Dual ST	1000Base-LX	-6.0	0.0	0.0	-17.0	6.0	1310	MMF	62.5	160	2 km (1.2 mi)
											50	500	1000m (3280 ft)
S-1110DP-S2SC10	2	Dual SC	1000Base-LX/LH	-9.5	-3.0	-20	-3.0	10.5	1310	MMF*	62.5	500	550 m (1,804 ft)
											50	400	550 m (1,804 ft)

												50	400	550 m (1,804 ft)
											SMF	**	-	10 km (6.2 mi)
S-1110DP-S2ST10	2	Dual ST	1000Base-LX/LH	-9.5	-3.0	-20	-3.0	10.5	1310	MMF*	62.5	500	550 m (1,804 ft)	
												50	400	550 m (1,804 ft)
												50	400	550 m (1,804 ft)
											SMF	**	-	10 km (6.2 mi)
S-1110DP-S2SC40	2	Dual SC	1000Base-EX	-2.0	2.0	-23	-3.0	21	1310	SMF	**	-	40 km (25 mi)	
S-1110DP-S2ST40	2	Dual ST	1000Base-EX	-2.0	2.0	-23	-3.0	21	1310	SMF	**	-	40 km (25 mi)	
S-1110DP-S2SC70	2	Dual SC	1000Base-ZX	-2.0	5.0	-23	-3.0	21	1550	SMF	-	-	70 km (43 mi)	
S-1110DP-S2ST70	2	Dual ST	1000Base-ZX	-2.0	5.0	-23	-3.0	21	1550	SMF	-	-	70 km (43 mi)	
S-1110DP-S2SC120	2	Dual SC	1000Base-ZX	0.0	5.0	-32	-9.0	32	1550	SMF	-	-	120 km (75 mi)	
S-1110DP-S2ST120	2	Dual ST	1000Base-ZX	0.0	5.0	-32	-9.0	32	1550	SMF	-	-	120 km (75 mi)	
S-1110DP-S2SC160	2	Dual SC	1000Base-ZX	2.0	5.0	-32	-9.0	34	1550	SMF	-	-	160 km (100 mi)	
S-1110DP-S2ST160	2	Dual ST	1000Base-ZX	2.0	5.0	-32	-9.0	34	1550	SMF	-	-	160 km (100 mi)	

Single Fiber Models Recommended use in pairs

Model	# PoE ports	Connector	Type	Transmit (dBm)		Receive (dBm)		Power Budget (dBm)	Wavelength (nm)	Fiber Type	Core Size (um)	Modal Bandwidth (MHz* Km)	Operating Distance
				Min	Max	Min	Max						
S-1110P-M1SC05U	1	Single SC	1000Base-BX-U	-10.0	-4.0	-17.0	-3.0	7.0	1310 / 1550	MMF	62.5	500	500 m (1,640 ft)
											50	500	500 m (1,640 ft)
S-1110P-M1SC05D	1	Single SC	1000Base-BX-D	-10.0	-4.0	-17.0	-3.0	7.0	1550 / 1310	MMF	62.5	500	500 m (1,640 ft)
											50	500	500 m (1,640 ft)
S-1110P-S1SC10U	1	Single SC	1000Base-BX-U	-9.0	-3.0	-20	-3.0	11	1310 / 1490	SMF	**	-	10 km (6.2 mi)
S-1110P-S1SC10D	1	Single SC	1000Base-BX-D	-9.0	-3.0	-20	-3.0	11	1490 / 1310	SMF	**	-	10 km (6.2 mi)
S-1110P-S1SC20U	1	Single SC	1000Base-BX-U	-8.0	-3.0	-22	-3.0	14	1310 / 1490	SMF	**	-	20 km (12.4 mi)
S-1110P-S1SC20D	1	Single SC	1000Base-BX-D	-8.0	-3.0	-22	-3.0	14	1490 / 1310	SMF	**	-	20 km (12.4 mi)
S-1110P-S1SC40U	1	Single SC	1000Base-BX-U	-3.0	2.0	-23	-3.0	20	1310 / 1490	SMF	**	-	40 km (25 mi)

S-1110P-S1SC40D	1	Single SC	1000Base-BX-D	-3.0	2.0	-23	-3.0	20	1490 / 1310	SMF	**	-	40 km (25 mi)
S-1110P-S1SC80U	1	Single SC	1000Base-BX-U	-2.0	3.0	-26	-3.0	24	1510 / 1590	SMF	-	-	80 km (50 mi)
S-1110P-S1SC80D	1	Single SC	1000Base-BX-D	-2.0	3.0	-26	-3.0	24	1590 / 1510	SMF	-	-	80 km (50 mi)
S-1110P-S1SC120U	1	Single SC	1000Base-BX-U	-3.0	2.0	-34	-9.0	31	1510 / 1590	SMF	-	-	120 km (75 mi)
S-1110P-S1SC120D	1	Single SC	1000Base-BX-D	-3.0	2.0	-34	-9.0	31	1590 / 1510	SMF	-	-	120 km (75 mi)
S-1110DP-M1SC05U	2	Single SC	1000Base-BX-U	-10.0	-4.0	-17.0	-3.0	7.0	1310 / 1550	MMF	62.5	500	500 m (1,640 ft)
											50	500	500 m (1,640 ft)
S-1110DP-M1SC05D	2	Single SC	1000Base-BX-D	-10.0	-4.0	-17.0	-3.0	7.0	1550 / 1310	MMF	62.5	500	500 m (1,640 ft)
											50	500	500 m (1,640 ft)
S-1110DP-S1SC10U	2	Single SC	1000Base-BX-U	-9.0	-3.0	-20	-3.0	11	1310 / 1490	SMF	**	-	10 km (6.2 mi)
S-1110DP-S1SC10D	2	Single SC	1000Base-BX-D	-9.0	-3.0	-20	-3.0	11	1490 / 1310	SMF	**	-	10 km (6.2 mi)
S-1110DP-S1SC20U	2	Single SC	1000Base-BX-U	-8.0	-3.0	-22	-3.0	14	1310 / 1490	SMF	**	-	20 km (12.4 mi)
S-1110DP-S1SC20D	2	Single SC	1000Base-BX-D	-8.0	-3.0	-22	-3.0	14	1490 / 1310	SMF	**	-	20 km (12.4 mi)
S-1110DP-S1SC40U	2	Single SC	1000Base-BX-U	-3.0	2.0	-23	-3.0	20	1310 / 1490	SMF	**	-	40 km (25 mi)
S-1110DP-S1SC40D	2	Single SC	1000Base-BX-D	-3.0	2.0	-23	-3.0	20	1490 / 1310	SMF	**	-	40 km (25 mi)
S-1110DP-S1SC80U	2	Single SC	1000Base-BX-U	-2.0	3.0	-26	-3.0	24	1510 / 1590	SMF	-	-	80 km (50 mi)
S-1110DP-S1SC80D	2	Single SC	1000Base-BX-D	-2.0	3.0	-26	-3.0	24	1590 / 1510	SMF	-	-	80 km (50 mi)
S-1110DP-S1SC120U	2	Single SC	1000Base-BX-U	-3.0	2.0	-34	-9.0	31	1510 / 1590	SMF	-	-	120 km (75 mi)
S-1110DP-S1SC120D	2	Single SC	1000Base-BX-D	-3.0	2.0	-34	-9.0	31	1590 / 1510	SMF	-	-	120 km (75 mi)

The minimum fiber cable distance for all converters listed is 2 meters.

*A mode-conditioning adapter as specified by the IEEE standard, is required regardless of the span length. Note how the mode conditioning adapter for 62.5-um fibers has a different specification from the mode-conditioning adapter for 50-um fibers.

**ITU-T G.652 SMF as specified by the IEEE 802.3z standard.

Media Converter Accessories

4 DIN Rail Mount Bkt DIN Rail Mounting Kit

MCSM

Standalone media converter wall mount bracket

Select a Model to obtain a Part Number - 10/100/1000 PoE+

Model	# PoE ports	Fiber Port Connector	Type	Transmit (dBm)		Receive (dBm)		Power Budget (dBm)	Wavelength (nm)	Fiber Type	Core Size (um)	Modal Bandwidth (MHz*km)	Operating Distance
				Min	Max	Min	Max						
S-1110PP-SFP	1	1 x SFP/LC	1000Base-X /100Base-X	-	-	-	-	-	-	MMF /SMF	-	-	-
S-1110PP-DSFP	1	2 x SFP/LC	1000Base-X /100Base-X	-	-	-	-	-	-	MMF /SMF	-	-	-
S-1110PP-M2SC05	1	Dual SC	1000Base-SX	-9.5	-4.0	-17	-3.0	7.5	850	MMF	62.5	160	220 m (722 ft)
											62.5	200	275 m (902 ft)
											50	400	500 m (1,640 ft)
											50	500	550 m (1,804 ft)
											50	2000	1000 m (3281 ft)
S-1110PP-M2ST05	1	Dual ST	1000Base-SX	-9.5	-4.0	-17	-3.0	7.5	850	MMF	62.5	160	220 m (722 ft)
											62.5	200	275 m (902 ft)
											50	400	500 m (1,640 ft)
											50	500	550 m (1,804 ft)
											50	2000	1000 m (3281 ft)
S-1110PP-M2SC2	1	Dual SC	1000Base-LX	-6.0	0.0	0.0	-17.0	6.0	1310	MMF	62.5	160	2 km (1.2 mi)
											50	500	1000m (3280 ft)
S-1110PP-M2ST2	1	Dual ST	1000Base-LX	-6.0	0.0	0.0	-17.0	6.0	1310	MMF	62.5	160	2 km (1.2 mi)
											50	500	1000m (3280 ft)
S-1110PP-S2SC10	1	Dual SC	1000Base-LX/LH	-9.5	-3.0	-20	-3.0	10.5	1310	MMF*	62.5	500	1000 m (3281 ft)
											50	400	550 m (1,804 ft)
											50	400	550 m (1,804 ft)
										SMF	**	-	10 km (6.2 mi)
S-1110PP-S2ST10	1	Dual ST	1000Base-LX/LH	-9.5	-3.0	-20	-3.0	10.5	1310	MMF*	62.5	500	550 m (1,804 ft)
											50	400	550 m (1,804 ft)

												50	400	550 m (1,804 ft)
											SMF	**	-	10 km (6.2 mi)
S-1110PP-S2SC40	1	Dual SC	1000Base-EX	-2.0	2.0	-23	-3.0	21	1310		SMF	**	-	40 km (25 mi)
S-1110PP-S2ST40	1	Dual ST	1000Base-EX	-2.0	2.0	-23	-3.0	21	1310		SMF	**	-	40 km (25 mi)
S-1110PP-S2SC70	1	Dual SC	1000Base-ZX	-2.0	5.0	-23	-3.0	21	1550		SMF	-	-	70 km (43 mi)
S-1110PP-S2ST70	1	Dual ST	1000Base-ZX	-2.0	5.0	-23	-3.0	21	1550		SMF	-	-	70 km (43 mi)
S-1110PP-S2SC120	1	Dual SC	1000Base-ZX	0.0	5.0	-32.0	-9.0	32	1550		SMF	-	-	120 km (75 mi)
S-1110PP-S2ST120	1	Dual ST	1000Base-ZX	0.0	5.0	-32.0	-9.0	32	1550		SMF	-	-	120 km (75 mi)
S-1110PP-S2SC160	1	Dual SC	1000Base-ZX	2.0	5.0	-32.0	-9.0	34	1550		SMF	-	-	160 km (100 mi)
S-1110PP-S2ST160	1	Dual ST	1000Base-ZX	2.0	5.0	-32.0	-9.0	34	1550		SMF	-	-	160 km (100 mi)
S-1110DPP-SFP	2	1 x SFP/LC	1000Base-X /100Base-X	-	-	-	-	-	-		MMF /SMF	-	-	-
S-1110DPP-DSFP	2	2 x SFP/LC	1000Base-X /100Base-X	-	-	-	-	-	-		MMF /SMF	-	-	-
S-1110DPP-M2SC05	2	Dual SC	1000Base-SX	-9.5	-4.0	-17	-3.0	7.5	850		MMF	62.5	160	220 m (722 ft)
												62.5	200	275 m (902 ft)
												50	400	500 m (1,640 ft)
												50	500	550 m (1,804 ft)
												50	2000	1000 m (3281 ft)
S-1110DPP-M2ST05	2	Dual ST	1000Base-SX	-9.5	-4.0	-17	-3.0	7.5	850		MMF	62.5	160	220 m (722 ft)
												62.5	200	275 m (902 ft)
												50	400	500 m (1,640 ft)
												50	500	550 m (1,804 ft)
												50	2000	1000 m (3281 ft)
S-1110DPP-M2SC2	2	Dual SC	1000Base-LX	-6.0	0.0	0.0	-17.0	6.0	1310		MMF	62.5	160	2 km (1.2 mi)
												50	500	1000m (3280 ft)
S-1110DPP-M2ST2	2	Dual ST	1000Base-LX	-6.0	0.0	0.0	-17.0	6.0	1310		MMF	62.5	160	2 km (1.2 mi)
												50	500	1000m (3280 ft)

S-1110DPP-S2SC10	2	Dual SC	1000Base-LX/LH	-9.5	-3.0	-20	-3.0	10.5	1310	MMF*	62.5	500	550 m (1,804 ft)
											50	400	550 m (1,804 ft)
											50	400	550 m (1,804 ft)
											SMF	**	-
S-1110DPP-S2ST10	2	Dual ST	1000Base-LX/LH	-9.5	-3.0	-20	-3.0	10.5	1310	MMF*	62.5	500	550 m (1,804 ft)
											50	400	550 m (1,804 ft)
											50	400	550 m (1,804 ft)
											SMF	**	-
S-1110DPP-S2SC40	2	Dual SC	1000Base-EX	-2.0	2.0	-23	-3.0	21	1310	SMF	**	-	40 km (25 mi)
S-1110DPP-S2ST40	2	Dual ST	1000Base-EX	-2.0	2.0	-23	-3.0	21	1310	SMF	**	-	40 km (25 mi)
S-1110DPP-S2SC70	2	Dual SC	1000Base-ZX	-2.0	5.0	-23	-3.0	21	1550	SMF	-	-	70 km (43 mi)
S-1110DPP-S2ST70	2	Dual ST	1000Base-ZX	-2.0	5.0	-23	-3.0	21	1550	SMF	-	-	70 km (43 mi)
S-1110DPP-S2SC120	2	Dual SC	1000Base-ZX	0.0	5.0	-32	-9.0	32	1550	SMF	-	-	120 km (75 mi)
S-1110DPP-S2ST120	2	Dual ST	1000Base-ZX	0.0	5.0	-32	-9.0	32	1550	SMF	-	-	120 km (75 mi)
S-1110DPP-S2SC160	2	Dual SC	1000Base-ZX	2.0	5.0	-32	-9.0	34	1550	SMF	-	-	160 km (100 mi)
S-1110DPP-S2ST160	2	Dual ST	1000Base-ZX	2.0	5.0	-32	-9.0	34	1550	SMF	-	-	160 km (100 mi)

Single Fiber Models Recommended use in pairs

Model	# PoE ports	Connector	Type	Transmit (dBm)		Receive (dBm)		Power Budget (dBm)	Wavelength (nm)	Fiber Type	Core Size (um)	Modal Bandwidth (MHz* Km)	Operating Distance
				Min	Max	Min	Max						
S-1110PP-M1SC05U	1	Single SC	1000Base-BX-U	-10.0	-4.0	-17.0	-3.0	7.0	1310 / 1550	MMF	62.5	500	500 m (1,640 ft)
											50	500	500 m (1,640 ft)
S-1110PP-M1SC05D	1	Single SC	1000Base-BX-D	-10.0	-4.0	-17.0	-3.0	7.0	1550 / 1310	MMF	62.5	500	500 m (1,640 ft)
											50	500	500 m (1,640 ft)
S-1110PP-S1SC10U	1	Single SC	1000Base-BX-U	-9.0	-3.0	-20	-3.0	11	1310 / 1490	SMF	**	-	10 km (6.2 mi)
S-1110PP-S1SC10D	1	Single SC	1000Base-BX-D	-9.0	-3.0	-20	-3.0	11	1490 / 1310	SMF	**	-	10 km (6.2 mi)
S-1110PP-S1SC20U	1	Single SC	1000Base-BX-U	-8.0	-3.0	-22	-3.0	14	1310 / 1490	SMF	**	-	20 km (12.4 mi)

S-1110PP-S1SC20D	1	Single SC	1000Base-BX-D	-8.0	-3.0	-22	-3.0	14	1490 / 1310	SMF	**	-	20 km (12.4 mi)
S-1110PP-S1SC40U	1	Single SC	1000Base-BX-U	-3.0	2.0	-23	-3.0	20	1310 / 1490	SMF	**	-	40 km (25 mi)
S-1110PP-S1SC40D	1	Single SC	1000Base-BX-D	-3.0	2.0	-23	-3.0	20	1490 / 1310	SMF	**	-	40 km (25 mi)
S-1110PP-S1SC80U	1	Single SC	1000Base-BX-U	-2.0	3.0	-26	-3.0	24	1510 / 1590	SMF	-	-	80 km (50 mi)
S-1110PP-S1SC80D	1	Single SC	1000Base-BX-D	-2.0	3.0	-26	-3.0	24	1590 / 1510	SMF	-	-	80 km (50 mi)
S-1110PP-S1SC120U	1	Single SC	1000Base-BX-U	-3.0	2.0	-34	-9.0	31	1510 / 1590	SMF	-	-	120 km (75 mi)
S-1110PP-S1SC120D	1	Single SC	1000Base-BX-D	-3.0	2.0	-34	-9.0	31	1590 / 1510	SMF	-	-	120 km (75 mi)
S-1110DPP-M1SC05U	2	Single SC	1000Base-BX-U	-10.0	-4.0	-17.0	-3.0	7.0	1310 / 1550	MMF	62.5	500	500 m (1,640 ft)
											50	500	500 m (1,640 ft)
S-1110DPP-M1SC05D	2	Single SC	1000Base-BX-D	-10.0	-4.0	-17.0	-3.0	7.0	1550 / 1310	MMF	62.5	500	500 m (1,640 ft)
											50	500	500 m (1,640 ft)
S-1110DPP-S1SC10U	2	Single SC	1000Base-BX-U	-9.0	-3.0	-20	-3.0	11	1310 / 1490	SMF	**	-	10 km (6.2 mi)
S-1110DPP-S1SC10D	2	Single SC	1000Base-BX-D	-9.0	-3.0	-20	-3.0	11	1490 / 1310	SMF	**	-	10 km (6.2 mi)
S-1110DPP-S1SC20U	2	Single SC	1000Base-BX-U	-8.0	-3.0	-22	-3.0	14	1310 / 1490	SMF	**	-	20 km (12.4 mi)
S-1110DPP-S1SC20D	2	Single SC	1000Base-BX-D	-8.0	-3.0	-22	-3.0	14	1490 / 1310	SMF	**	-	20 km (12.4 mi)
S-1110DPP-S1SC40U	2	Single SC	1000Base-BX-U	-3.0	2.0	-23	-3.0	20	1310 / 1490	SMF	**	-	40 km (25 mi)
S-1110DPP-S1SC40D	2	Single SC	1000Base-BX-D	-3.0	2.0	-23	-3.0	20	1490 / 1310	SMF	**	-	40 km (25 mi)
S-1110DPP-S1SC80U	2	Single SC	1000Base-BX-U	-2.0	3.0	-26	-3.0	24	1510 / 1590	SMF	-	-	80 km (50 mi)
S-1110DPP-S1SC80D	2	Single SC	1000Base-BX-D	-2.0	3.0	-26	-3.0	24	1590 / 1510	SMF	-	-	80 km (50 mi)
S-1110DPP-S1SC120U	2	Single SC	1000Base-BX-U	-3.0	2.0	-34	-9.0	31	1510 / 1590	SMF	-	-	120 km (75 mi)
S-1110DPP-S1SC120D	2	Single SC	1000Base-BX-D	-3.0	2.0	-34	-9.0	31	1590 / 1510	SMF	-	-	120 km (75 mi)

The minimum fiber cable distance for all converters listed is 2 meters.

*A mode-conditioning adapter as specified by the IEEE standard, is required regardless of the span length. Note how the mode conditioning adapter for 62.5-um fibers has a different specification from the mode-conditioning adapter for 50-um fibers.

**ITU-T G.652 SMF as specified by the IEEE 802.3z standard.

Media Converter Accessories

4 DIN Rail Mount Bkt DIN Rail Mounting Kit

MCSM Standalone media converter wall mount bracket

Copyright © 1996 - 2021 Perle. All Rights Reserved