

03032SKC-C

Huawei® 34060321 Compatible TAA 1000Base-SX SFP Transceiver (MMF, 850nm, 550m, LC, DOM)

Features:

- Compatible with CFP2 MSA Specification
- Compatible with QSFP28 MSA Specification
- Single 3.3V Power Supply and Power Dissipation < 1.8W
- Case Temperature Range: 0 to 70
- Hot Pluggable 104-Pin Connector
- 4x 25G CFP2 Electrical Plug Interface Provided
- 4x 25G QSFP28 Electrical Socket Interface Provided
- Management and Control via MDIO 2-Wire Interface
- RoHS compliant and Lead Free



Applications:

- 100GBase Ethernet
- Access and Enterprise

Product Description

This Huawei® 03032SKC compatible QSFP28 to QSFP28 converter provides conversion from CFP2 to QSFP28 form factors. It is guaranteed to be 100% compatible with the equivalent Huawei® converter. This easy to install, hot swappable converter has been programmed, uniquely serialized and data-traffic and application tested to ensure that it will initialize and perform identically. Digital optical monitoring (DOM) support is also present to allow access to real-time operating parameters. This converter is Trade Agreements Act (TAA) compliant. We stand behind the quality of our products and proudly offer a limited lifetime warranty.

ProLabs' transceivers are RoHS compliant and lead-free.

TAA refers to the Trade Agreements Act (19 U.S.C. & 2501-2581), which is intended to foster fair and open international trade. TAA requires that the U.S. Government may acquire only "U.S. – made or designated country end products."



Absolute Maximum Ratings

Parameter	Symbol	Min.	Typ.	Max.	Unit	Notes
Storage Temperature	Tstg	-40		85	°C	
Operating Case Temperature	Tc	0		70	°C	
Power Supply Current	Icc			550	mA	
Aggregate Bit Rate	BRave		103.125	111.8	Gbps	
Lane Bit Rate	BRlane		25.78	27.95	Gbps	

Electrical Characteristics

Parameter	Symbol	Min.	Typ.	Max.	Unit	Notes
Power Supply Voltage	Vcc	3.135	3.3	3.465	V	
Transmitter						
Differential Input Amplitude	VIN	150		1000	mVp-p	1
Differential Input Impedance	ZIN	85	100	115	Ω	2
Tx_Disable	Disable	VIH	2	Vcc+0.3	V	
	Enable	VIL	0	0.8	V	
Receiver						
Differential Output Amplitude	VOUT	340		400	mVp-p	3
Differential Output Impedance	ZOUT	85	100	115	Ω	
Output Rise/Fall Time	Tr/Tf	24			ps	4
Rx_LOS	LOS	VOH	2.4	Vcc+0.3	V	
	Normal	VOL	0	0.8	V	

Notes:

1. AC coupled inputs.
2. RIN > 100kΩ @ DC.
3. AC coupled outputs.
4. 20-80%.

1.2V MDIO Interface Specifications

Parameter	Symbol	Min.	Typ.	Max.	Unit	Notes
Input Voltage	VIH	0.84		1.5	V	
	VIL	-0.3		0.36	V	
Input Leak Current	IIN	-100		100	uA	
Output Voltage	VOH	1.0		1.5	V	
	VOL	-0.3		0.2	V	
Input Capacitance	Ci			10	pF	
Input MDC Clock	fMDC	0.1		4	MHz	
MDC Clock Period	tMDC	250		10000	ns	
MDIO Hold Time	Thold	10			ns	
MDIO Setup Time	Tsetup	10			ns	
GLB_ALM	Tglb_alm_ass			150	ms	
	Tglb_alm_dea			150	ms	

CFP2 Pin Function Definitions

Bottom		Top	
1	GND	53	GND
2	(TX_MCK_N)	54	N.C.
3	(TX_MCK_P)	55	N.C.
4	GND	56	GND
5	N.C.	57	Rx0+
6	N.C.	58	Rx0-
7	3.3V_GND	59	GND
8	3.3V_GND	60	Rx1+
9	3.3V	61	Rx1-
10	3.3V	62	GND
11	3.3V	63	N.C.
12	3.3V	64	N.C.
13	3.3V_GND	65	GND
14	3.3V_GND	66	N.C.
15	VND_IO_A	67	N.C.
16	VND_IO_B	68	GND
17	PRG_CNTL1	69	Rx2+
18	PRG_CNTL2	70	Rx2-
19	PRG_CNTL3	71	GND
20	PRG_ALARM1	72	Rx3+
21	PRG_ALARM2	73	Rx3-
22	PRG_ALARM3	74	GND
23	GND	75	N.C.

24	Tx_Disable	76	N.C.
25	Rx_LOS	77	GND
26	MOD_LOPWR	78	(REFCLKp)
27	MOD_ABS	79	(REFCLKp)
28	MOD_RSTn	80	GND
29	GLB_ALRMn	81	N.C.
30	GND	82	N.C.
31	MDC	83	GND
32	MDIO	84	Tx0+
33	PRTADR0	85	Tx0-
34	PRTADR1	86	GND
35	PRTADR2	87	Tx1+
36	VND_IO_C	88	Tx1-
37	VND_IO_D	89	GND
38	VND_IO_E	90	N.C.
39	3.3V_GND	91	N.C.
40	3.3V_GND	92	GND
41	3.3V	93	N.C.
42	3.3V	94	N.C.
43	3.3V	95	GND
44	3.3V	96	Tx2+
45	3.3V_GND	97	Tx2-
46	3.3V_GND	98	GND
47	N.C.	99	Tx3+
48	N.C.	100	Tx3-
49	GND	101	GND
50	(RX_MCK_N)	102	N.C.
51	(RX_MCK_P)	103	N.C.
52	GND	104	GND

CFP2 Electrical Pad Layout

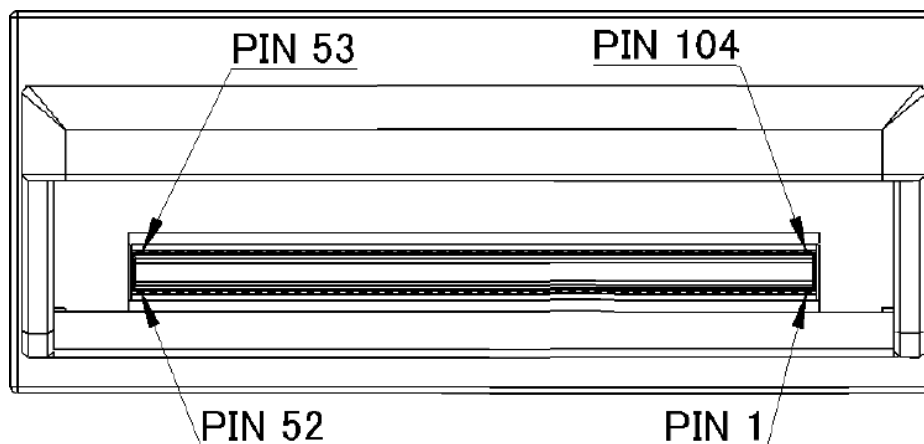

Bottom Row Pin Descriptions

Pin	Symbol	Function	Notes
1	GND		
2	(TX_MCK_N)	O CML	1
3	(TX_MCK_P)	O CML	1
4	GND		
5	N.C.		
6	N.C.		
7	3.3V_GND		
8	3.3V_GND		
9	3.3V		2
10	3.3V		2
11	3.3V		2
12	3.3V		2
13	3.3V_GND		
14	3.3V_GND		
15	VND_IO_A		3
16	VND_IO_B		4
17	PRG_CNTL1		5
18	PRG_CNTL2		6
19	PRG_CNTL3		7
20	PRG_ALARM1		8
21	PRG_ALARM2		9
22	PRG_ALARM3		10
23	GND		
24	Tx_Disable	I LVCMOS	11
25	Rx_LOS	O LVCMOS	12
26	MOD_LOPWR	I LVCMOS	13
27	MOD_ABS	O GND	14
28	MOD_RSTn	I LVCMOS	15
29	GLB_ALARMn	O LVCMOS	16
30	GND		
31	MDC	I 1.2V CMOS	17
32	MDIO	I/O 1.2V CMOS	18
33	PRTADRO	I 1.2V CMOS	19
34	PRTADR1	I 1.2V CMOS	20
35	PRTADR2	I 1.2V CMOS	21

36	VND_IO_C	I/O	22
37	VND_IO_D	I/O	23
38	VND_IO_E	I/O	24
39	3.3V_GND		
40	3.3V_GND		
41	3.3V		2
42	3.3V		2
43	3.3V		2
44	3.3V		2
45	3.3V_GND		
46	3.3V_GND		
47	N.C.		25
48	N.C.		25
49	GND		
50	(RX_MCK_N)	O CML	1
51	(RX_MCK_P)	O CML	1
52	GND		

Notes:

1. For optical waveform testing. Not for normal use.
2. 3.3V module supply voltage.
3. Module Vendor I/O A. Do not connect.
4. Module Vendor I/O B. Do not connect.
5. Programmable control 1 set over MDIO. MSA default: TRXIC_RSTn/TX&RX ICs reset. "0" is reset, and "1" or "NC" means enabled/not used.
6. Programmable Control 2 set over MDIO. MSA default: Hardware Interlock LSB. "00" is $\leq 3W$, "01" is $\leq 6W$, "10" is $\leq 9W$, and "11" or NC is $\leq 12W$ which is not used.
7. Programmable Control 3 set over MDIO. MSA default: Hardware Interlock MSB. "00" is $\leq 3W$, "01" is $\leq 6W$, "10" is $\leq 9W$, and "11" or NC is $\leq 12W$ which is not used.
8. Programmable Alarm 1 set over MDIO. MSA default: HIPWR_ON. "1" indicates that the module power-up is complete, and "0" indicates that the module is not high powered-up.
9. Programmable Alarm 2 set over MDIO. MSA default: MOD_READY. "1" is ready, and "0" is not ready.
10. Programmable Alarm 3 set over MDIO. MSA default: MOD_FAULT (fault detected). "1" is fault, and "0" is not fault.
11. Transmitter disables for all lanes. "1" or NC is transmitter disabled, and "0" is transmitter enabled.
12. Receiver loss of optical signal. "1" is low optical signal, and "0" is normal condition.
13. Module low-power mode. "1" or NC is module in low-power (safe) mode, and "0" is power-on enabled.
14. Module Absent. "1" or NC is module absent, and "0" is module present. Pull-up resistor on the host.
15. Module Reset. "0" resets the module, and "1" or NC is module enabled. Pull-down resistor in the module.
16. Global Alarm. "0" is the alarm condition in any MDIO alarm register, and "1" is no alarm condition. Open Drain. Pull-up resistor on the host.

17. Management Data Clock.
18. Management Data I/O Bi-Directional Data.
19. MDIO Physical Port Address Bit 0.
20. MDIO Physical Port Address Bit 1.
21. MDIO Physical Port Address Bit 2.
22. Module Vendor I/O C. Do not connect.
23. Module Vendor I/O D. Do not connect.
24. Module Vendor I/O E. Do not connect.
25. Not Connected.

Top Row Pin Descriptions

Pin	Symbol	Function	Notes
53	GND		
54	N.C.		
55	N.C.		
56	GND		
57	Rx0+	Lane 0 Rx Output O	1
58	Rx0-	Lane 0 Rx Output O	1
59	GND		
60	Rx1+		1
61	Rx1-		1
62	GND		
63	N.C.		
64	N.C.		
65	GND		
66	N.C.		
67	N.C.		
68	GND		
69	Rx2+	Lane 2 Rx Output O	1
70	Rx2-	Lane 2 Rx Output O	1
71	GND		
72	Rx3+	Lane 3 Rx Output O	1
73	Rx3-	Lane 3 Rx Output O	1
74	GND		
75	N.C.		
76	N.C.		
77	GND		
78	(REFCLKn)	Reference Clock I	2

79	(REFCLKp)	Reference Clock I	2
80	GND		
81	N.C.		
82	N.C.		
83	GND		
84	Tx0+	Lane 0 Tx Input I	3
85	Tx0-	Lane 0 Tx Input I	3
86	GND		
87	Tx1+	Lane 1 Tx Input I	3
88	Tx1-	Lane 1 Tx Input I	3
89	GND		
90	N.C.		
91	N.C.		
92	GND		
93	N.C.		
94	N.C.		
95	GND		
96	Tx2+	Lane 2 Tx Input I	3
97	Tx2-	Lane 2 Tx Input I	3
98	GND		
99	Tx3+	Lane 3 Tx Input I	3
100	Tx3-	Lane 3 Tx Input I	3
101	GND		
102	N.C.		
103	N.C.		
104	GND		

Notes:

1. CML Output.
2. Reference Clock Input.
3. CML Input.
4. Ground connections are common for Tx and Rx.
5. Each connector contact is rated at 0.5A.
6. MDIO and MDC timing must comply with IEEE 802.3ae clause 45.3.
7. Converter will be MSA compliant when no signals are present on the vendor-specific pins.

Block Diagram

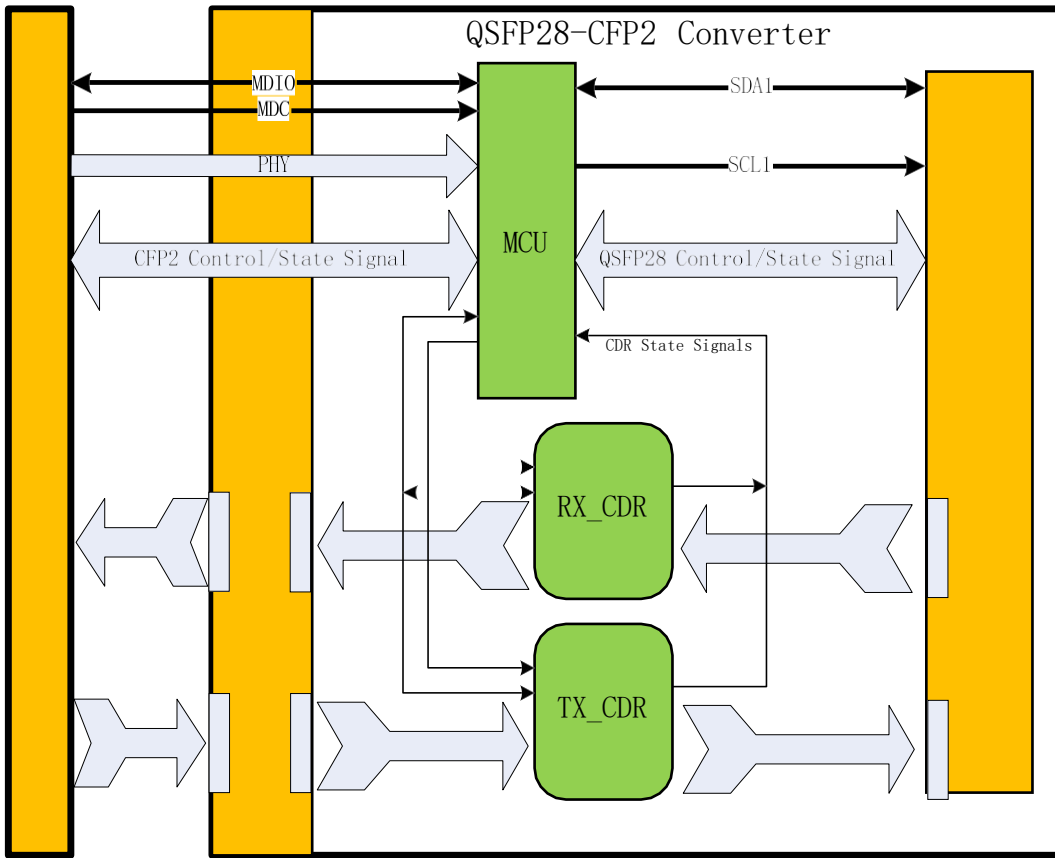

Mechanical Specifications

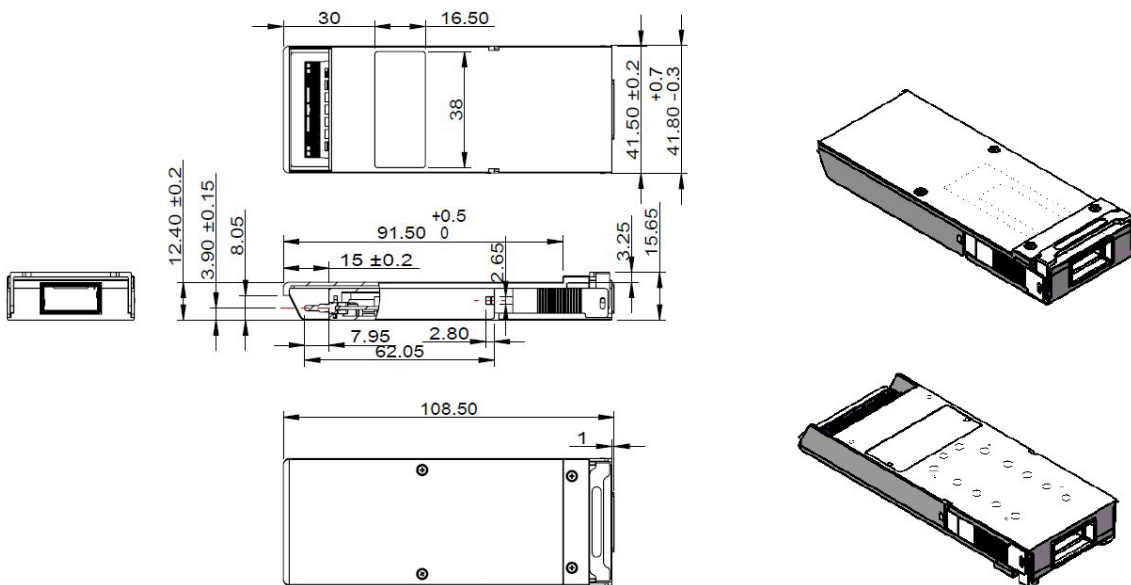

About ProLabs

Our experience comes as standard; for over 15 years ProLabs has delivered optical connectivity solutions that give our customers freedom and choice through our ability to provide seamless interoperability. At the heart of our company is the ability to provide state-of-the-art optical transport and connectivity solutions that are compatible with over 90 optical switching and transport platforms.

Complete Portfolio of Network Solutions

ProLabs is focused on innovations in optical transport and connectivity. The combination of our knowledge of optics and networking equipment enables ProLabs to be your single source for optical transport and connectivity solutions from 100Mb to 400G while providing innovative solutions that increase network efficiency. We provide the optical connectivity expertise that is compatible with and enhances your switching and transport equipment.

Trusted Partner

Customer service is our number one value. ProLabs has invested in people, labs and manufacturing capacity to ensure that you get immediate answers to your questions and compatible product when needed. With Engineering and Manufacturing offices in the U.K. and U.S. augmented by field offices throughout the U.S., U.K. and Asia, ProLabs is able to be our customers best advocate 24 hours a day.



Contact Information

ProLabs US

Email: sales@prolabs.com

Telephone: 952-852-0252

ProLabs UK

Email: salessupport@prolabs.com

Telephone: +44 1285 719 600